



**EMERSON**<sup>TM</sup>

Original Instructions  
1019570 - REV. 03



# 2000 X energy Power Supply

# Operating Manual

**Branson Ultrasonics Corp.**  
120 Park Ridge Road  
Brookfield, CT 06804  
(203) 796-0400  
<http://www.bransonultrasonics.com>

**BRANSON**



## Manual Change Information

At Branson, we strive to maintain our position as the leader in ultrasonics plastics joining, cleaning and related technologies by continually improving our circuits and components in our equipment. These improvements are incorporated as soon as they are developed and thoroughly tested.

Information concerning any improvements will be added to the appropriate technical documentation at its next revision and printing. Therefore, when requesting service assistance for specific units, note the Revision information found on this document, refer to the printing date which appears on this page, and refer to [Appendix C: Manual Revisions](#) to see the appropriate revision of manual you need according to the manufacturing date of your Power Supply.

## Copyright

Copyright © 2025 Branson Ultrasonics Corporation.

All rights reserved.

Contents of this publication may not be reproduced in any form without the written permission of Branson Ultrasonics Corporation.

Loctite is a registered trademark of Henkel Corporation U.S.A. Other trademarks and service marks mentioned herein are held by their respective owners.

## Foreword

Congratulations on your choice of a Branson Ultrasonics Corporation system!

The Branson 2000-Series system is process equipment for the joining of plastic parts using ultrasonic energy. It is the newest generation of product using this sophisticated technology for a variety of customer applications. This Operating Manual is part of the documentation set for this system, and should be kept with the equipment.

Thank you for choosing Branson!

## Introduction

This manual is arranged into several structured chapters which will help you find the information you may need to know to safely handle, install, set up, program, operate, and/or maintain this product. Please refer to the [Table of Contents](#) and/or the [Index](#) of this manual to find the information you may be looking for. In the event you require additional assistance or information, please contact our Product Support department (see [1.4 How to Contact Branson](#) for information on how to contact them) or your local Branson representative.

---

# Table of Contents

---

## Chapter 1: Safety and Support

1.1	Safety Requirements and Warnings . . . . .	2
1.2	General Precautions . . . . .	3
1.3	Warranty Statement, Disclaimer . . . . .	6
1.4	How to Contact Branson . . . . .	8
1.5	Returning Equipment for Repair . . . . .	9
1.6	Obtaining Replacement Parts . . . . .	12

## Chapter 2: The 2000X energy Power Supply

2.1	Models Covered . . . . .	14
2.2	Overview of these Models . . . . .	15
2.3	Compatibility with Branson Products . . . . .	16
2.4	Features . . . . .	17
2.5	Front Panel Controls . . . . .	21
2.6	Welding Systems . . . . .	22
2.7	Glossary . . . . .	23

## Chapter 3: Delivery and Handling

3.1	Shipping and Handling . . . . .	30
3.2	Receiving . . . . .	31
3.3	Unpacking . . . . .	32
3.4	Returning Equipment . . . . .	33

## Chapter 4: Installation and Setup

4.1	About Installation . . . . .	36
4.2	Handling and Unpacking . . . . .	37
4.3	Take Inventory of Small Parts . . . . .	41
4.4	Installation Requirements . . . . .	43
4.5	Installation Steps . . . . .	48
4.6	Start Switch Connection (Automation) . . . . .	55
4.7	Guards and Safety Equipment . . . . .	64
4.8	Rack Mount Installation . . . . .	65
4.9	Assemble the Acoustic Stack . . . . .	67
4.10	Installing the Ultrasonic Stack in the Actuator . . . . .	72
4.11	Testing the Installation . . . . .	75
4.12	Still Need Help? or Parts? Have Questions? . . . . .	76

## Chapter 5: Technical Specifications

5.1	Technical Specifications . . . . .	78
5.2	Physical Description . . . . .	80
5.3	Standard Modules and Components . . . . .	81

## Chapter 6: Operation

6.1	Front Panel Controls . . . . .	91
6.2	System Menus . . . . .	95
6.3	Setting Primary Parameters . . . . .	99
6.4	Setting Other Weld Parameters . . . . .	114
6.5	Saving and Recalling Presets . . . . .	137
6.6	Using the Diagnostics Menu . . . . .	147

6.7	Viewing System Information . . . . .	153
6.8	Using the System Configuration Menu . . . . .	156
6.9	Using the Horn Down Feature . . . . .	184
6.10	Using the Test Feature . . . . .	185

## **Chapter 7: Maintenance**

7.1	2000 Series Preventive Maintenance . . . . .	188
7.2	Parts Lists . . . . .	192
7.3	Circuits . . . . .	195
7.4	Troubleshooting . . . . .	197
7.5	System Alarm Tables . . . . .	199
7.6	Service Events . . . . .	249
7.7	Parts Replacement . . . . .	252

## **Appendix A: Automation**

A.1	FAQ: 2000 SERIES AUTOMATION . . . . .	266
-----	---------------------------------------	-----

## **Appendix B: Alarm Index**

## **Appendix C: Manual Revisions**

C.1	Manual Revisions . . . . .	278
-----	----------------------------	-----

# List of Figures

## Chapter 1: Safety and Support

Figure 1.1	CE Mark	5
------------	---------	---

## Chapter 2: The 2000X energy Power Supply

Figure 2.1	2000X Power Supply Front Panel Display after Power-Up	21
------------	---	----

## Chapter 3: Delivery and Handling

## Chapter 4: Installation and Setup

Figure 4.1	Unpacking the Stand (Actuator on a Base); left-side view of Stand	38
Figure 4.2	Unpacking the Stand (Actuator on a Hub); Hub shown separately	39
Figure 4.3	Ultrasonic Converter (J-Type for stand use) and Booster	40
Figure 4.4	ae Actuator Dimensional Drawing	44
Figure 4.5	Power Supply Dimensional Drawing	45
Figure 4.6	Base Mounting Centers	49
Figure 4.7	Mounting Bolt Pattern for the Hub (for Stand on Hub)	50
Figure 4.8	Actuator Rear View, Mounting Surface, Bolt and Guide Pin Locations	51
Figure 4.9	Connections on Rear of Power Supply	52
Figure 4.10	Electrical Connections from Power Supply to a 2000-series Actuator	54
Figure 4.11	Start Switch Connection Codes	55
Figure 4.12	User I/O Cable Identification and Wire Color Diagram	56
Figure 4.13	International Harmonized Line Cord Color Code	60
Figure 4.14	DIP Switch Location on the Analog and Digital Power Supply Module	61
Figure 4.15	Switch Select Block	62
Figure 4.16	Actuator Emergency Stop Button	64
Figure 4.17	Detail of Rack Mount Handle Kit Assembly	65
Figure 4.18	Assembling the 20 kHz Acoustic Stack	70
Figure 4.19	Connecting Tip to Horn	71
Figure 4.20	Installing a 20 kHz Stack in a Branson Actuator	72
Figure 4.21	Installing the 40 kHz Stack in a Branson Actuator	73
Figure 4.22	Mounting Circles on Base	74
Figure 4.23	Normal Front Panel Display after Power -Up	75

## Chapter 5: Technical Specifications

Figure 5.1	Rear View of 2000X Power Supply	80
Figure 5.2	20 kHz CR20 Converter Dimensions	82
Figure 5.3	20 kHz Booster Dimensions	83
Figure 5.4	20 kHz Converter/Booster/Horn, Typical Dimensions	83
Figure 5.5	30 kHz Converter Dimensions	84
Figure 5.6	30 kHz Booster Dimensions	84
Figure 5.7	30 kHz, CA - 30 Converter with Booster	85
Figure 5.8	30 kHz Converter/Booster/Horn, Typical Dimensions	85
Figure 5.9	40 kHz, 4TR and 4TJ Converter Dimensions	86
Figure 5.10	40 kHz, 4TH Converter Dimensions	86
Figure 5.11	40 kHz, 4TP Converter Dimensions	86
Figure 5.12	40 kHz Booster Dimensions	87
Figure 5.13	40 kHz Converter/Booster/Horn, Typical Dimensions	87

## **Chapter 6: Operation**

Figure 6.1 Front Panel of the 2000X Power Supply . . . . .	91
--	----

## **Chapter 7: Maintenance**

Figure 7.1 Block Diagram, Power Supply and Actuator . . . . .	195
Figure 7.2 Interconnect Diagram, Power Supply . . . . .	196
Figure 7.3 Exploded View of all 2000 Modules . . . . .	253
Figure 7.4 Front Panel, Exploded Parts View . . . . .	254
Figure 7.5 Location and Orientation of U53, U54, U55, and U56 . . . . .	260
Figure 7.6 Lineboard EDP 100-242-1199R (100-242-1230R for 4kW Units). . . . .	261

## **Appendix A: Automation**

## **Appendix B: Alarm Index**

## **Appendix C: Manual Revisions**

Figure C.1 Location of the Model Data Label on the back of the Power Supply . . . . .	278
Figure C.2 Locating the Manufacturing Date . . . . .	278

# List of Tables

## Chapter 1: Safety and Support

Table 1.1	Warranty Period	6
Table 1.2	Branson Contacts	10

## Chapter 2: The 2000X energy Power Supply

Table 2.1	Power Supply Compatibility with Branson Converters	16
-----------	--	----

## Chapter 3: Delivery and Handling

Table 3.1	Environmental Specifications	30
Table 3.2	Inspecting the Power Supply upon delivery	31
Table 3.3	Unpacking the Power Supply	32

## Chapter 4: Installation and Setup

Table 4.1	Small Parts Included (=x) with Power Supply and/or Actuator Assemblies	41
Table 4.2	List of Cables	41
Table 4.3	Environmental Specifications	46
Table 4.4	Input Power Requirements	46
Table 4.5	User I/O Cable Pin Assignments, Alphabetical Order	57
Table 4.6	User I/O Input and Output Function Selection	59
Table 4.7	User I/O DIP Switch Functions	60
Table 4.8	Changing Power Supply Module DIP switch settings	62
Table 4.9	DIP Switch Settings*	63
Table 4.10	Rack Mount Handle Kit Assembly	65
Table 4.11	Tools	67
Table 4.12	Assembling the Acoustic Stack in a 20 kHz System	67
Table 4.13	Assembling the Acoustic Stack in a 30 kHz System	68
Table 4.14	Assembling the Acoustic Stack in a 40 kHz System	69
Table 4.15	Stud Torque Values	70
Table 4.16	Tip to Horn Torque Values	71

## Chapter 5: Technical Specifications

Table 5.1	Environmental Requirements	78
Table 5.2	Electrical Input Operating Voltages	78
Table 5.3	Input Current and Fuse Requirements	78

## Chapter 6: Operation

Table 6.1	Navigation through the 2000X Power Supply menus	92
Table 6.2	Testing the Welding System after installation	94
Table 6.3	Adjusting the Weld Setup from the Run Screen	97
Table 6.4	Viewing Weld Results	97
Table 6.5	Summary of Weld Modes	99
Table 6.6	Selecting a Weld Mode	100
Table 6.7	Setting Welding Time	103
Table 6.8	Setting Weld Energy	106
Table 6.9	Setting the percentage of Peak Power	109
Table 6.10	Setting Scrub Time	113
Table 6.11	Setting Hold Time	114
Table 6.12	Setting Amplitude (%)	115
Table 6.13	Setting Stepped Amplitude	116

Table 6.14	Setting Pretrigger . . . . .	118
Table 6.15	Setting the Afterburst . . . . .	120
Table 6.16	Turning Energy Braking on or off . . . . .	121
Table 6.17	Digital UPS setup . . . . .	122
Table 6.18	Setting the Post Weld Seek . . . . .	123
Table 6.19	Setting the Frequency Offset . . . . .	124
Table 6.20	Setting Cycle Aborts . . . . .	126
Table 6.21	Setting the Timeout . . . . .	128
Table 6.22	Setting the Control Limits . . . . .	129
Table 6.23	Setting the Suspect Limits . . . . .	131
Table 6.24	Setting the Reject Limits . . . . .	134
Table 6.25	Write in Fields . . . . .	136
Table 6.26	Saving a Preset . . . . .	139
Table 6.27	Recalling a Preset . . . . .	142
Table 6.28	Clearing a Preset . . . . .	143
Table 6.29	Preset Information . . . . .	145
Table 6.30	Verify Presets. . . . .	146
Table 6.31	Viewing Diagnostics . . . . .	148
Table 6.32	Setting Digital Tune . . . . .	150
Table 6.33	Performing a Horn Scan . . . . .	152
Table 6.34	Viewing System Information . . . . .	154
Table 6.35	Selecting Language for the Power Supply . . . . .	160
Table 6.36	Selecting Units for the Power Supply. . . . .	160
Table 6.37	Setting a Password . . . . .	161
Table 6.38	Selecting a Start Screen . . . . .	162
Table 6.39	Resetting the Presets Counter . . . . .	163
Table 6.40	Setting Parameters for RS232 . . . . .	164
Table 6.41	Code Output . . . . .	165
Table 6.42	Using Welder Address . . . . .	166
Table 6.43	Turning the General Alarm Reset On or Off . . . . .	167
Table 6.44	Setting the System Time . . . . .	168
Table 6.45	Setting the System Date . . . . .	168
Table 6.46	Turning Beeper On or Off. . . . .	169
Table 6.47	Setting the Amplitude Control . . . . .	170
Table 6.48	Setting the Cylinder Diameter . . . . .	171
Table 6.49	Setting the Cylinder Stroke . . . . .	172
Table 6.50	Custom Actuator Settings . . . . .	174
Table 6.51	Setting Extra Cooling . . . . .	174
Table 6.52	Alarms and their causes . . . . .	175
Table 6.53	Configuring the User I/O . . . . .	177
Table 6.54	Features for User I/O Inputs . . . . .	178
Table 6.55	Features for User I/O Outputs . . . . .	179
Table 6.56	Setting the Scale for Bar Graphs . . . . .	181
Table 6.57	Turning the Digital Filter On or Off . . . . .	182
Table 6.58	Setting the Frequency Offset Control . . . . .	183
Table 6.59	Using the Horn Down Feature. . . . .	184
Table 6.60	Using the Test Feature . . . . .	185

## Chapter 7: Maintenance

Table 7.1	Component Replacements Based on Cycles Run . . . . .	190
Table 7.2	Replacement Parts List for 2000X Power Supply. . . . .	192
Table 7.3	2000-Series System Cables (External) . . . . .	193
Table 7.4	Suggested Spares. . . . .	194
Table 7.5	Alarm Message. . . . .	197
Table 7.6	Cycle Modified Alarms and Messages, with Probable Cause and Corrective Action. . . . .	199
Table 7.7	Failure of Alarms and Messages, with Probable Cause and Corrective Action . . . . .	202
Table 7.8	No Cycle Alarms and Messages, with Probable Cause and Corrective Action. . . . .	207

Table 7.9	Suspect/Reject Alarms and Messages, with Probable Cause and Corrective Action. . . . .	210
Table 7.10	Setup Alarms and Messages, with Probable Cause and Corrective Action . . . . .	219
Table 7.11	Overload Alarms . . . . .	246
Table 7.12	Note Alarms . . . . .	247
Table 7.13	Voltage Test Points . . . . .	249
Table 7.14	Performing a Cold Start . . . . .	250
Table 7.15	Removing the VDF Display . . . . .	255
Table 7.16	Removing the Power Supply Module . . . . .	256
Table 7.17	Removing the DC Power Supply . . . . .	257
Table 7.18	Removing the User I/O Board . . . . .	258
Table 7.19	Removing and Replacing the BBRAM battery. . . . .	259
Table 7.20	Removing the System Controller Board . . . . .	259
Table 7.21	Removing the Line Board . . . . .	262
Table 7.22	Removing and Replacing the Line Fuses. . . . .	263
Table 7.23	Removing a Cooling Fan. . . . .	264

### **Appendix A: Automation**

Table A.1	Air Consumption . . . . .	270
-----------	---------------------------	-----

### **Appendix B: Alarm Index**

### **Appendix C: Manual Revisions**

Table C.1	Revisions of Manual . . . . .	278
-----------	-------------------------------	-----



---

# Chapter 1: Safety and Support

---




<b>1.1</b>	<b>Safety Requirements and Warnings</b> .....	<b>2</b>
<b>1.2</b>	<b>General Precautions</b> .....	<b>3</b>
<b>1.3</b>	<b>Warranty Statement, Disclaimer</b> .....	<b>6</b>
<b>1.4</b>	<b>How to Contact Branson</b> .....	<b>8</b>
<b>1.5</b>	<b>Returning Equipment for Repair</b> .....	<b>9</b>
<b>1.6</b>	<b>Obtaining Replacement Parts</b> .....	<b>12</b>

This chapter contains an explanation of the different Safety Notice symbols and icons found both in this manual and on the product itself and provides additional safety information for ultrasonic welding. This chapter also describes how to contact Branson for assistance.

## 1.1 Safety Requirements and Warnings

### 1.1.1 Symbols found in this Manual

These symbols used throughout the manual warrant special attention:

<b>WARNING</b>	<b>Indicates a possible danger</b>
	If these risks are not avoided, death or severe injury might result.
<b>CAUTION</b>	<b>Indicates a possible danger</b>
	If these risks are not avoided, slight or minor injury might result.
<b>NOTICE</b>	<b>Indicates a possible damaging situation</b>
	If this situation is not avoided, the system or something in its vicinity might get damaged. Application types and other important or useful information are emphasized.


### 1.1.2 Symbols found on the Product


The 2000 X energy Power Supply has several warning labels on it to indicate the presence of hazardous voltages inside the unit.

## 1.2 General Precautions

Take the following precautions before servicing the power supply:

- Be sure the power switch is in the Off position before making any electrical connections.
- To prevent the possibility of an electrical shock, always plug the power supply into a grounded power source.
- Power supplies produce high voltage. Before working on the power supply module, do the following:
  - Turn off the power supply;
  - Unplug main power; and
  - Allow at least 5 minutes for capacitors to discharge
- High voltage is present in the power supply. Do not operate with the cover removed
- High line voltages exist in the ultrasonic power supply module. Common points are tied to circuit reference, not chassis ground. Therefore, use only non-grounded, battery-powered multimeters when testing these modules. Using other types of test equipment can present a shock hazard
- Be sure power is disconnected from the power supply before setting a DIP switch
- Keep hands from under the horn. Down force (pressure) and ultrasonic vibrations can cause injury
- Do not cycle the welding system if either the RF cable or converter is disconnected
- When using larger horns, avoid situations where fingers could be pinched between the horn and the fixture

CAUTION	
	<p>Sound level and frequency of the noise emitted during the ultrasonic assembly process may depend upon <b>a.</b> type of application, <b>b.</b> size, shape and composition of the material being assembled, <b>c.</b> shape and material of the holding fixture, <b>d.</b> welder setup parameters and <b>e.</b> tool design. Some parts vibrate at an audible frequency during the process. Some or all of these factors may result in an uncomfortable noise being emitted during the process. In such cases operators may need to be provided with personal protective equipment.</p> <p>See 29 CFR (Code of Federal Regulations) 1910.95 Occupational Noise Exposure.</p>


CAUTION	
	<p>First aid measures (in case of electrolyte leakage from the battery):</p> <p><b>Eye Contact:</b> Flush the eyes with plenty of clean water for at least 15 minutes immediately, without rubbing. Get immediate medical treatment.</p> <p>If appropriate procedures are not taken, this may cause eye injury.</p> <p><b>Skin Contact:</b> Wash the affected area under tepid running water using a mild soap. If appropriate procedures are not taken, this may cause sores on the skin. Get medical attention if irritation develops or persists.</p> <p><b>Inhalation:</b> Remove to fresh air immediately. Get medical treatment immediately.</p>

## 1.2.1 Intended Use of the System

The 2000X Power Supply and Actuator are components of an ultrasonic welding system. These are designed for a wide variety of welding or processing applications.

## 1.2.2 Emissions

When being processed, certain plastic materials can emit toxic fumes and/or gases hazardous to user health. Where such materials are processed, proper ventilation of the workstation is required. Check with your materials suppliers for recommended protection when processing their materials. See 29 CFR (Code of Federal Regulations) 1910.134, Respiratory protection.

CAUTION	
	Processing of many materials, such as PVC, can be hazardous to an operator's health and could cause corrosion/damage to the equipment. Use proper ventilation and take protective measures.

## 1.2.3 Setting up the Workplace

Measures for setting up a workplace for safe operation of the ultrasonic welder are outlined in [Chapter 4: Installation and Setup](#) and in the 2000 Series *Installation Guide*.

## 1.2.4 Regulatory Compliance

The Branson 2000X Series products (Power Supply and Actuator/Stand and Welder) are designed to be in compliance with the following U.S. regulatory and agency guidelines and standards:

All 20, 30, and 40 kHz products:

- ANSI Z535.1 Safety Color Code
- ANSI Z535.3 Criteria for Safety Symbols
- ANSI Z535.4 Product Safety Signs and Labels
- NFPA 70 National Electric Code Article 670 Industrial Machinery
- NFPA 79 Electrical Standard for Industrial Machinery
- 29 CFR 1910.212 OSHA General Requirements for all machines
- 47 CFR Part 18 Federal Communications Commission
- BS EN ISO 12100-1, 2 Safety of Machinery - Basic concepts, general principles for design
- EN 55011 Limits and methods of measurement of radio disturbance of industrial, scientific and medical radio-frequency equipment
- EN 60204-1 Safety of Machinery - Electrical Equipment of machines
- EN 61000-6-2 Electromagnetic Compatibility - Generic standards - Immunity for industrial environments
- EN 61310-1, 2 Safety of Machinery - Indication, marking, actuation
- EN 60529 Degrees of protection provided by enclosure
- EN 60664-1 Insulation coordination for equipment within low-voltage systems

40 kHz products with CE Mark: Same as above plus:

- EN 61000-3-2 Electromagnetic Compatibility - Limits for harmonic emissions (for European products that draw less than 1000 watts from the line at full rated power)
- EN 61000-3-3 Electromagnetic Compatibility - Limitations of voltage fluctuations and flicker in low voltage supply systems (for European products that draw less than 1000 watts from the line at full rated power)

**Figure 1.1** CE Mark



## 1.2.5 Compliance with Safety Standards

### Products: 2000X Series Power Supply and Actuator/Stand

A standard 2000X Series Power Supply when connected to a 2000 Series Stand with dual start switches and an emergency stop switch (mounted in the Base) is in compliance with the following OSHA requirements:

#### **29 CFR Chapter XVII - Occupational Safety and Health Administration - Subpart O - Machinery and Machine Guarding - Section 1910.212 General requirements for all machines Subsection (a) Machine guarding.**

When it is operated in this configuration it provides Point of operation guarding specified in 1910.212 (a) (3) by using two hand tripping devices and electronic safety devices specified in 1910.212 (a) (1) Types of guarding.

In accordance with 29 CFR 1910.212 (a) (3) (ii) and Directive 2006/42/EC of the European Parliament, the electronic controller located in 2000X Power Supply has been designed in accordance with the requirements of:

#### **NFPA 79 Electrical Standard for Industrial Machinery 2002 Edition EN ISO 121000-1, -2 Safety of machinery - Basic concepts, general principles for design EN 954 Safety related parts of control systems (Category 3), ISO 13851 Two-hand control devices (Type IIIB), EN 60204-1 Electrical equipment of machines (Type III).**

These standards require concurrent actuation of the two control devices (start switches) by both hands (within a specified time) during the hazardous condition. Machine operation ceases upon release of either one or both of the control devices when the hazardous condition is still present. Both control devices must be released before operation can be re-initiated.

If the 2000 Series Actuator or Stand is not used with dual start switches, mounted in a Series 2000 Base, then it may not be in compliance with OSHA and European requirements unless some other means of safety actuation or guarding has been provided.

An additional requirement of Section 10-910.212 (b) is that the machine must be securely anchored to prevent walking or moving.

## 1.3 Warranty Statement, Disclaimer

The following excerpts from the “Terms and Conditions of Sale” (found on the back of your Invoice) are essential guidelines for the product Warranty issued with your Branson ultrasonic welding components. The items listed in this section specifically address issues involving the delivery, shipment, and warranty period provided. If you have any questions, please refer to the back of the Invoice included with your system, which lists all of the Terms and Conditions of Sale, or contact your Branson representative.

### TERMS AND CONDITIONS OF SALE

Branson Ultrasonics Corporation is herein referred to as the “Seller” and the customer or person or entity purchasing products (“Products”) from Seller is referred to as the “Buyer”. Buyer’s acceptance of the Products will manifest Buyer’s assent to these Terms and Conditions.

### ULTRASONIC JOINING EQUIPMENT NORTH AMERICAN WARRANTY POLICY

Each product manufactured by Branson is guaranteed to be free from *defects in material and workmanship* for a period of time specified in [Table 1.1 Warranty Period](#) from the date of invoice.

**Table 1.1** Warranty Period

Product	Warranty Period
Power Supplies	36 months
Actuators	36 months
Integrated Welders	36 months
Accessories	36 months
Converters	36 months (limited to <i>one-time</i> replacement)
Non-Branson equipment	warranted by the manufacturer
Horns	12 months (limited to <i>one-time</i> replacement)
Boosters	36 months
Rental Equipment	Same as purchased equipment
Hand Guns	12 months
Specials and products with EDP prefix 159-xxx-xxx	12 months
Specials and products with EDP prefix 125-xxx-xxx	12 months

The warranty does *not* apply to:

- Any product which has been subject to misuse, misapplication, neglect (including without limitation inadequate maintenance), accident or improper installation, modification or adjustment
- Applications requiring metal-to-metal contact when the ultrasonic exposure time exceeds 1.5 seconds
- Any product exposed to adverse environments, improper repair or repairs using non-Branson methods or material
- Non-Branson equipment (i.e., horns, boosters, converters) or improperly tuned horns
- Set up/installation of equipment and software updates

Warranty Service covers the following:

Repair service at Branson's main repair facility or a regional office

- Includes parts and labor performed at Branson authorized repair facilities. The customer must return the equipment properly packed with all shipping charges prepaid

Repair service at the customer site:

- Includes parts and labor at the customer site performed by a Branson technician. The customer is responsible for all travel-related charges

Module trade-in:

- Includes serialized components for work performed by the customer. The customer orders the replacement components from the Parts Store and issues a P.O. When the failed components are returned to Branson the warranty status is verified and a credit is issued. The customer is responsible for all shipping charges

Additional Warranty Notes:

- Components replaced during in-warranty repair carries the remainder of the original warranty
- Serialized assemblies replaced during the repair of out-of-warranty equipment are warranted for a period of 12 months
- Travel charges for Branson service personnel will be waived on service calls performed within 30 days of invoice date
- Non-serialized parts replaced during the repair of out-of-warranty equipment are warranted for 3 months
- Trade in allowance: Branson out-of-warranty serialized components are entitled to a 25% trade in allowance regardless of age or condition, however, converters must be less than 5 years old to qualify for the trade in

If you have any questions concerning the warranty coverage (including coverage outside of North America), please contact your Branson representative or Branson Customer Support.

## 1.4 How to Contact Branson

Branson is here to help you. We appreciate your business and are interested in helping you successfully use our products. To contact Branson for help, use the following telephone numbers, or contact the field office nearest you.

- **Brookfield Main Number (all Departments):** (203) 796-0400 (Eastern Time Zone)
- **Parts Store (direct number):** (877) 330-0406 (Central Time Zone)
- **Repair department:** (877)-330-0405 (Central Time Zone)
- **For emergency after-hours service (5pm-8am Est):** (203) 796-0500 (US phone numbers only)

Tell the operator which product you have and which person or department you need ([Table 1.2: Branson Contacts](#)). If after hours, please leave a voice message with your name and return telephone number.

### 1.4.1 Before Calling Branson for Assistance

This manual provides information for troubleshooting and resolving problems that could occur with the equipment (see [Chapter 7: Maintenance](#)). If you still require assistance, Branson Product Support is here to help you. To help identify the problem, use the following questionnaire which lists the common questions you will be asked when you contact the Product Support department.


Before calling, determine the following information:

1. Your company name and location.
2. Your return telephone number.
3. Have your manual with you. If troubleshooting a problem, refer to [Chapter 7: Maintenance](#).
4. Know your equipment model and serial numbers (found on a gray data label on the units). Information about the Horn (part number, gain, etc.) or other tooling may be etched into the tooling. Software- or firmware-based systems may provide a BOS or software version number, which may be required.
5. What tooling (horn) and booster are being used?
6. What are the setup parameters and mode?
7. Is your equipment in an automated system? If so, what is supplying the "start" signal?
8. Describe the problem; provide as much detail as possible. For example, is the problem intermittent? How often does it occur? How long before it occurs if you are just powering up? If an error is occurring, which error (give error number or name)?
9. List the steps you have already taken.
10. What is your application, including the materials being processed?
11. Have a list of service or spare parts you have on hand (tips, horns, etc.)
12. Notes: \_\_\_\_\_  
\_\_\_\_\_  
\_\_\_\_\_

## 1.5 Returning Equipment for Repair

Before sending equipment for repair, provide as much information with the equipment to help determine the problem with the system. Fill in any details below or on a separate sheet.

Describe the problem; provide as much detail as possible. For example, is this a new problem? Is the problem intermittent? How often does it occur? How long before it occurs if you are just powering up?

NOTICE	
	<p>To return equipment to Branson, you must first obtain an <b>RGA number</b> from a Branson representative, or the shipment may be delayed or refused.</p>

If you are returning equipment to Branson for repair, you must first call the Repair department to obtain a **Returned Goods Authorization (RGA)** number. (If you request it, the repair department will fax a Returned Goods Authorization form to fill out and return with your equipment.)

**Branson Repair Department, C/O Zuniga Logistics, LTD**  
**12013 Sara Road, Killam Industrial Park**  
**Laredo, Texas 78045 U.S.A.**  
**direct telephone number: (877) 330-0405**  
**fax number: (877) 330-0404**

- Provide as much information as possible that will help identify the need for repair
- Carefully pack the equipment in original packing cartons
- Clearly label all shipping cartons with the RGA number on the outside of cartons as well as on your packing slip, along with the reason for return
- Return general repairs by any convenient method. Send priority repairs by air freight
- You must prepay the transportation charges FOB Laredo, Texas, U.S.A.

### 1.5.1 Get an RGA Number

RGA# \_\_\_\_\_

If you are returning equipment to Branson, please call the Repair Department to obtain a Returned Goods Authorization (RGA) number. (At your request, the Repair Department will fax an RGA form to fill out and return with the equipment.)

### 1.5.2 Record information about the Problem

Before sending equipment for repair, record the following information and send a copy of it with the equipment. This will greatly increase Branson’s ability to address the problem.

1. Describe the problem; provide as much detail as possible.  
 For example, is the problem intermittent? How often does it occur? How long before it occurs after powering up?

---



---



---

2. Is your equipment in an automated system? NO / YES

3. If the problem is with an external signal, which signal? \_\_\_\_\_

If known, include plug/pin # (e.g., P29, pin #3) for that signal: \_\_\_\_\_

4. What are the Weld Parameters?

---



---

5. What is your application? (Type of weld, plastic material, etc.)

---



---

6. Name and phone number of the person most familiar with the problem:

---



---

7. Contact the Branson office prior to shipping the equipment.

8. For equipment not covered by warranty, to avoid delay, include a Purchase Order.

**Send a copy of this page with the equipment being returned for repair.**

### 1.5.3 Departments to Contact

Call your local Branson Representative, or contact Branson by calling, and asking for the appropriate department as indicated in [Table 1.2 Branson Contacts](#) below.

**Table 1.2** Branson Contacts

What you need help with or information about	Whom to Call	At this Phone Number
Information about new welding systems or components	Your local Branson Rep or Branson Customer Service	203-796-0400 Ext 384
Application and Setup questions on the welding system	Welding Applications Lab	203-796-0400 Ext 368
Application assistance on the Horns and Tooling	ATG Lab	203-796-0400 Ext 495
Technical questions about the welding system	Welding Product Support	203-796-0400 Ext 355
Technical questions about Horns and Tooling	ATG Lab	203-796-0400 Ext 495
Ordering new parts	Parts Store	877-330-0406
RGA's, Request for Repair, Status of a Repair	Welding Repair Department	877-330-0405
System Automation/Hookup Information	Product Support	203-796-0400 Ext 355

My Local Branson Representative's name is:

---

I can reach this representative at:

---

## 1.5.4 Pack and Ship the Equipment

1. Carefully pack the system in original packing material to avoid shipping damage. Plainly show the RGA number on the outside of cartons as well as inside the carton along with the reason for return. Make a list of all components packed in the box. **KEEP YOUR MANUAL.**
2. Return general repairs by any convenient method. Send priority repairs by air freight. Prepay the transportation charges FOB the repair site.

NOTICE	
	Items that are sent Freight Collect will be refused.

## 1.6 Obtaining Replacement Parts

You can reach Branson Parts Store at the following telephone numbers:

**Branson Part Store**

**direct telephone number: 877-330-0406**

**fax number: 877-330-0404**

Many parts can be shipped the same day if ordered before 2:30 p.m., Eastern time.

A parts list is found in [Chapter 7: Maintenance](#) of this manual, listing descriptions and EDP part numbers. If you need replacement parts, coordinate the following with your purchasing agent:

- Purchase order number
- 'Ship to' information
- 'Bill to' information
- Shipping instructions (air freight, truck, etc.)
- Any special instructions (for example, "Hold at the airport and call"). Be sure to give a name and phone number
- Contact name information

---

## **Chapter 2: The 2000X energy Power Supply**

---

<b>2.1</b>	<b>Models Covered . . . . .</b>	<b>14</b>
<b>2.2</b>	<b>Overview of these Models . . . . .</b>	<b>15</b>
<b>2.3</b>	<b>Compatibility with Branson Products . . . . .</b>	<b>16</b>
<b>2.4</b>	<b>Features . . . . .</b>	<b>17</b>
<b>2.5</b>	<b>Front Panel Controls . . . . .</b>	<b>21</b>
<b>2.6</b>	<b>Welding Systems . . . . .</b>	<b>22</b>
<b>2.7</b>	<b>Glossary . . . . .</b>	<b>23</b>

This manual provides detailed instructions for installation, setup, operation, and maintenance of 2000X Power Supply. For detailed information on operation and maintenance of other components connected to the Power Supply, refer to appropriate Actuator instruction manual.

This Power Supply contains a microprocessor-based controller that provides for control and monitoring of welding operations.

## 2.1 Models Covered

This manual covers the 2000X Power Supply with the digital UPS configuration. See [Appendix C: Manual Revisions](#) for information on models covered with this manual.

### 2.1.1 Power Supply Manual and Guides

The following documentation is available for the Branson 2000X Power Supply:

- 2000 X ea Instruction Manual (EDP 1019570)
- 2000-Series System Installation Guide (EDP 100-214-226)
- 2000 X ea Quick Start User's Guide (EDP 100-412-169)

### 2.1.2 Actuator Manuals

The following documentation is available for the Branson Actuators compatible with this power supply:

- 2000-Series System Installation Guide (EDP 100-214-226)
- 2000 X ae Actuator Instruction Manual (EDP 1019571)

## 2.2 Overview of these Models

The 2000X generates ultrasonic electrical energy through an ultrasonic converter for welding plastics. Several models are available, depending on the desired frequency (for example, 20 kHz) or the desired power range (for example, 2.5 kW). The Power Supply also contains a microprocessor-based controller module that provides for control and monitoring of welding operations.

The Power Supply provides the following features:

- AutoTune with Memory (AT/M) — Allows the Power Supply to track and store the horn frequency of the last weld
- Auto Seek — Tracks and starts the horn on the correct frequency. It does this by running the horn at a low-level amplitude (5%) to find and lock on to the horn operating frequency
- Line Regulation — Maintains converter amplitude by regulating for variances in the line voltages.
- Load Regulation — Maintains converter amplitude over the full range of rated power
- System Protection Monitor — Protects the Power Supply by providing five levels of protection
  - 1 Voltage
  - 2 Current
  - 3 Phase
  - 4 Temperature
  - 5 Power
- Select Start — Provides four starting ranges. Select Start in the Analog UPS allows the Power Supply to ramp up amplitude at four different rates to accommodate different horn and load requirements. Select Start in the Digital UPS allows Memory and Timed Seek to be turned on or off, and allows a range of time values to be input for Ramp Time(s) and Seek Time(s)
- Frequency Offset — Provides for applying an external frequency offset to the operating frequency

## 2.3 Compatibility with Branson Products

The 2000X Power Supply is designed to be used with:

- 2000ae Actuator (Actuator alone, or Actuator Stand on a Base or on a Hub)

**Table 2.1** Power Supply Compatibility with Branson Converters

2000X energy Model	Converter
20 kHz/1250 W	CJ20 CR20
20 kHz/2500 W	
20 kHz/4000 W	
30 kHz/750 W	CJ30 CR30 CH30
30 kHz/1500 W	
40 kHz/400 W	4TH 4TJ 4TP 4TR
40 kHz/800 W	

## 2.4 Features

### 2.4.1 The Welding System

The welding system consists of a Power Supply and a converter-booster-horn stack. The system can perform ultrasonic welding, inserting, staking, spot welding, swaging, degating, and continuous ultrasonic operations. It is designed for automated, semi-automated and/or manual production operations.

Listed below are the control features of the Branson 2000-series ultrasonic welding system.

- **1 Millisecond Control and Sampling Rate:** This feature provides sampling and control of the weld process 1000 times each second
- **16 Presets:** User-configurable setups that can be preset allowing you to simply recall a weld setup to start production
- **19" Rack Mount Enclosure:** Compatible with industry standard 19" rack enclosure systems. Rack mount handles are available as an optional kit
- **Adjust While Running:** The 2000X allows you to modify the weld parameters while the welder is running. This can be of benefit in automated systems where you do not want to shut down the entire line to make a minor modification
- **Afterburst:** This feature allows you to turn on the ultrasonics after the weld and hold steps to reliably release parts from the horn
- **Alarms, Process:** These are set values used for part quality monitoring
- **Amplitude Stepping:** A Patented Branson Process. At a specified time, energy, peak power, distance, or by external signal you can change the amplitude during the weld to control the flow of plastic. This feature helps ensure part consistency, higher strength parts, and control of flash
- **Automatic Preset Naming:** If you choose not to name your preset, the Power Supply will give it a name that describes the weld mode and main parameter setting
- **Autotuning:** Ensures that the welder is running at peak efficiency
- **Cycle Aborts:** These are user programmed conditions (missing part and ground detect) at which the cycle is terminated. These can be used as safety limits to save wear and tear on the system and your tooling
- **Cycle Time and Date Stamp:** The Power Supply provides each cycle with a time and date stamp for production and quality control purposes. Clock is year 2000 and leap year compliant
- **Digital Amplitude Setting:** This feature allows you to set the exact amplitude necessary for your application, affording increased range and setting repeatability over analog systems
- **Digital Tuning:** Means to tune the Power Supply for applications and horns at the extremes of the Power Supply capture range
- **Digital UPS:** The Digital UPS has programmable (through a digital interface from a system controller) features which allow true autotune and start ramp during set-up. Power supply presets can be customized
- **Downspeed:** Sets the advance speed of the horn towards the workpiece
- **English (USCS)/Metric Units:** This feature allows the welder to be programmed in the local units in use
- **Foreign Languages:** Software supports user selectable languages at start up; English, French, German, Italian and Spanish
- **Frequency Offset:** This feature provides a user-set frequency value used in very limited applications where the fixture or anvil causes a frequency shift in the Power Supply's operation. This feature should be used only when advised by Branson
- **Graphs, Auto-Scaling:** Not supported in Power Supplies manufactured since April 2025. See [Appendix C: Manual Revisions](#) for information on manufacture dates.

- **Graphs, Printing of Power, Amplitude, Frequency, and Horn Scan for DUPS:** Not supported in Power Supplies manufactured since April 2025. See [Appendix C: Manual Revisions](#) for information on manufacture dates.
- **Graphs, User Selectable:** In any mode you can select the scale of the time axis on any graph so that you can zoom in on the start of the weld cycle
- **Hold Force:** Force applied to the workpiece while ultrasonic vibrations are removed
- **Horn Down:** Clamp On: When in the horn down mode, the start switches can be released after the part is contacted while the part remains clamped in place. Press horn down key again to release. Clamp Off: The horn will retract whenever the start switches are released in the horn down mode
- **Horn Down Display:** During Horn Down, the absolute Distance, Force, Velocity, and Pressure are displayed digitally so that you can determine correct values for process limits and cutoffs
- **Horn Down Mode:** A manual procedure used to verify system setup and alignment
- **Horn Scan:** A scan to enhance selection of operating frequency and control parameters. This feature is available in the DUPS only
- **Limits, Control:** These are controls that are used in conjunction with the main weld mode. These user programmed limits provide for additional control of the weld process
- **Limits, Reject:** A class of user-definable process alarms that alert you if a part falls into a range that you classified as reject parts
- **Limits, Suspect:** A class of user-definable process alarms that alert you if a part falls into a range that you have determined should be inspected
- **Memory:** When Memory is turned on, weld parameters at the end of the cycle will be entered
- **Membrane Keyboard:** For high reliability and immunity from factory dust and oils
- **Parallel Port:** Not supported in Power Supplies manufactured since April 2025. See [Appendix C: Manual Revisions](#) for information on manufacture dates.
- **Parameter Entry through Keypad:** A keypad is provided for direct entry. The Plus (+) and Minus (-) keys are provided for adjusting existing values
- **Parameter Range Checking:** If you enter an invalid parameter the Power Supply shows you the valid range
- **Password Protection:** This feature allows you to secure your setup from unauthorized changes. You can select your own password
- **Presets:** The UPS is capable of storing up to 12 presets of power supply operating parameters depending on feature level and type of UPS
- **Pretrigger:** This feature allows you to turn on the ultrasonics before contact with the part to increase performance
- **Print, Background:** Not supported in Power Supplies manufactured since April 2025. See [Appendix C: Manual Revisions](#) for information on manufacture dates.
- **Print, Data:** Not supported in Power Supplies manufactured since April 2025. See [Appendix C: Manual Revisions](#) for information on manufacture dates.
- **Print, Now:** Not supported in Power Supplies manufactured since April 2025. See [Appendix C: Manual Revisions](#) for information on manufacture dates.
- **Print, on Alarm:** Not supported in Power Supplies manufactured since April 2025. See [Appendix C: Manual Revisions](#) for information on manufacture dates.
- **Print, on Sample:** Not supported in Power Supplies manufactured since April 2025. See [Appendix C: Manual Revisions](#) for information on manufacture dates.
- **Printing, Weld History:** Not supported in Power Supplies manufactured since April 2025. See [Appendix C: Manual Revisions](#) for information on manufacture dates.
- **Rapid Traverse:** Allows a high horn travel speed for a portion of the stroke. Once the set distance is reached, travel speed is reduced to the downspeed setting
- **Ramp Starting:** The starting of the Power Supply and horn is done at the optimum rate to reduce electrical and mechanical stress on the system

- **Seek, Post Weld:** This feature provides a Seek at the end of the cycle to automatically retune the Power Supply
- **Seek:** Ensures operation at resonance; minimizes tuning errors; and operates the stack at low amplitude (approximately 5%), then provides a means of sensing and storing the resonant operating frequency value
- **Setup Checking:** If you create a setup with conflicts the Power Supply notifies you of the specific conflict
- **Short Cut to Modify Main Parameters:** From the Run Screen you can jump to a screen to make modifications to your main parameters. This simplifies minor adjustments
- **Start-up Diagnostics:** At start-up, the controls test the major system components
- **System Information Screen:** This is a screen that will give you information about your welding system. Refer to this screen when contacting Branson for service and support
- **Test Diagnostics:** In Test mode you can view the ultrasonic system results using digital readouts and bar graphs
- **Timed Seek:** When turned ON, will do a Seek once every minute to update horn resonant frequency to memory. This is especially useful when the welding process affects the actual temperature of the horn, causing a resonant frequency shift
- **User-Nameable Presets:** You can refer to each preset by name or part number making identification of your presets simple
- **Vacuum Fluorescent Display:** For good visibility in factory lighting conditions
- **View Weld Results:** From the Run Screen you can view any of the information available from the last completed cycle
- **Weld Modes:** Time, Energy, Peak Power, and Ground Detect. The 2000X welder offers multiple weld modes so that you can choose the mode of control that best meets your specific application need

### 2.4.2 The Power Supply

The Power Supply consists of an ultrasonic Power Supply module and a system controller. The ultrasonic Power Supply module converts conventional 50/60 Hz line current to 15 kHz, 20 kHz, 30 kHz or 40 kHz electrical energy. The system controller controls the welding system.

The power supply is configured with either an analog or digital UPS. The analog supply has one preset which calls up the factory default setting.

The digital supply has a library of up to 18 locked presets which are accessible for various process parameter modifications that are unique to the power supply itself. These modifications can be named to reflect specific applications, and are loaded into memory prior to shipment from the Branson Factory. The parameters of the individual presets can be modified by a Branson representative. Initially, one preset is set to factory default. They are accessed via an RS232 link to the system controller.

### 2.4.3 The Actuator

The Actuator is an electro-pneumatic system that contains the Ultrasonic Stack (Converter/Booster/Horn) that delivers the force and ultrasonic energy to the workpiece. The pneumatics are enclosed in the upper half of the actuator.

#### The Converter

The converter is mounted in the actuator as part of the ultrasonic stack. The ultrasonic electrical energy from the power supply is applied to the converter (sometimes called the transducer). This transforms the high frequency electrical oscillations into mechanical vibrations at the same frequency as the electrical oscillations. The heart of the converter is piezoelectric ceramic elements. When subjected to an alternating voltage, these elements alternately expand and contract, resulting in better than 90% conversion of electrical to mechanical energy.

## **The Booster**

Success in ultrasonic assembly depends on the right amplitude of movement at the horn face. Amplitude is a function of horn shape, which is largely determined by the size and form of the parts to be assembled. The booster can be used as a mechanical transformer to increase or decrease the amplitude of vibrations applied to the parts through the horn.

The booster is a resonant half-wave section of aluminum or titanium. It is mounted between the converter and the horn, as part of the ultrasonic stack. It also provides a clamping point for rigid stack mounting.

Boosters are designed to resonate at the same frequency as the converter with which they are used. Boosters are usually mounted at a nodal (minimum vibration) point of axial motion. This minimizes the loss of energy and prevents vibration from being transmitted into the actuator.

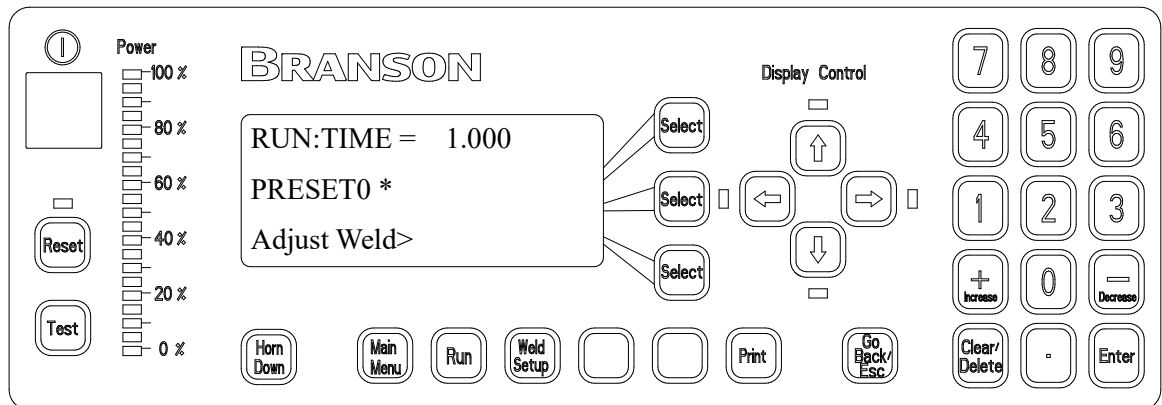
## **The Horn**

The horn is selected or designed for a specific application. Each horn is tuned typically as a half-wave section that applies the necessary force and vibration uniformly to the parts to be assembled. It transfers ultrasonic vibrations from the converter to the workpiece. The horn is mounted to the booster as part of the ultrasonic stack.

Depending on their profile, horns are referred to as stepped, conical, exponential, bar, or catenoidal. The shape of the horn determines the amplitude at the face of the horn. Depending on the application, horns can be made from titanium alloys, aluminum, or steel. Titanium alloys are the best materials for horn fabrication due to their high level of strength and low loss. Aluminum horns are usually chrome- or nickel-plated or hard-coated to reduce wear. Steel horns are for low amplitude requiring hardness, such as ultrasonic insertion applications.

## 2.5 Front Panel Controls

**Figure 2.1** 2000X Power Supply Front Panel Display after Power-Up



- **Select Keys:** Each key is associated with a Menu Item line. Press a key to select a line of the menu
- Display Control keys and LEDs:
  - LEDs adjacent to each control key indicate “more item lines exist” in the direction of the arrow that is lit
  - Press the Up and Down arrow keys to scroll the menu page in increments of one line
  - Press the Left and Right arrow keys to scroll across an extended menu screen (for example, Weld Results)
- **Numeric Keypad:** Press to select values
- **Power Bar Graph:** Indicates the percentage of rated power delivered either during the last weld cycle or when Test is running. The indicator's scale can be increased for low-power settings
- **Power:** Press to turn the system On and Off. When you depress the button, it lights to indicate power is On
- **Reset:** Press to clear alarms. Reset only functions on the Run screen
- **Test:** Press to display a menu you can use to test the ultrasonic power supply, horn, booster, and converter
- **Horn Down:** Press to activate a menu for Horn Down and fixture alignment when the ultrasonics are Off. Menus guide you through the process
- **Print:** Not supported in Power Supplies manufactured since April 2025. See [Appendix C: Manual Revisions](#) for information on manufacture dates.
- **Weld Setup:** Press to go to the Setup menu
- **Run:** Press to go to the Run screen
- **Main Menu:** Press to return to the Main Menu
- **Go Back/Esc:** Press to return the current menu page to the previous menu or sub-menu; when modifying a parameter, press this key to cancel editing and restore the parameter to its last saved value. Repeated pressing returns you to the Main Menu
- **+ Increase:** Press to increase a parameter value
- **- Decrease:** Press to decrease a parameter value
- **Enter:** Press Enter to accept a choice or to enter into memory the value of a parameter you have set
- **Clear/Delete:** Erases the selected value

## 2.6 Welding Systems

### 2.6.1 Principle of Operation

Thermoplastic parts are welded ultrasonically by applying high frequency vibrations to the parts being assembled. The vibrations, through surface and intermolecular friction, produce a sharp rise in temperature at the welding interface.

When the temperature is high enough to melt the plastic, there is a flow of material between the parts. When the vibrations stop, the material solidifies under pressure and a weld results.

Most plastics welders operate at a frequency above the range of human hearing (18 kHz) and are thus called ultrasonic.

### 2.6.2 Weld System Applications

2000X weld systems can be used for the following applications:

- Ultrasonic welding
- Cutting and sealing thermoplastic fabric and film
- Staking, spot welding, swaging, and degating thermoplastic parts
- Other ultrasonic processing applications

## 2.7 Glossary

The following terminology may be encountered when using or operating a 2000-series ultrasonic welding system. Some of these terms may not be available in all Controls (Power Supply model) configurations:

**AB Amplitude:** The amplitude at the horn face during the afterburst step.

**AB Delay:** Time delay between the end of the hold and the start of afterburst.

**AB Time:** The time duration of the afterburst.

**Abort Current Printing:** Not supported in Power Supplies manufactured since April 2025. See [Appendix C: Manual Revisions](#) for information on manufacture dates.

**Absolute Cutoff:** Ends the ultrasonic portion of the cycle when the set parameter is reached.

**Absolute Distance:** The distance the horn has travelled from home.

**Absolute Mode:** A mode of operation in which the weld is terminated when a user-specified distance from the home position has been reached.

**Absolute Position:** The position of the Actuator from the home position.

**Accept-as-is:** A disposition permitted for a nonconforming item when it can be established that the item is satisfactory for its intended use without violating safety or functional requirements.

**Actual:** A reported value that occurred during the weld cycle. The converse is the set parameter that was requested during the setup.

**Act Clr Output:** Actuator Clear output signal, sent upon the welder reaching a safe position of the actuator return stroke. Used in automated systems.

**Actuator:** The unit that houses the converter, booster, and horn assembly in a rigid mounting allowing it to move up and down either mechanically or pneumatically to apply a predetermined pressure on the workpiece.

**Adjust While Running:** Allows modifications to weld parameters while the welder is running.

**Afterburst:** Ultrasonic energy applied after the hold step. Used to break away sticking parts from the tooling.

**Alarm Beeper:** An audible signal that sounds when a general alarm has occurred.

**Amplitude:** The peak-to-peak movement at the horn face. Always expressed as a percentage of the maximum.

**Amp A:** The amplitude applied to the part from the start of the weld to the step change.

**Amp B:** The amplitude applied to the part from the step change to the end of the weld.

**Amplitude Graph:** A graph of amplitude percentage plotted against time.

**Amplitude Step:** A change in amplitude during the ultrasonic portion of the cycle.

**Amp Control:** The ability to set amplitude digitally or by an external control.

**Automatic:** A pretrigger condition indicating that pretrigger engages when the actuator leaves the upper limit switch.

**Baud Rate:** The rate of data transmission over the serial communication port.

**Beep:** An audible signal produced by the Branson control board. Used to alert the operator to an unexpected condition or that trigger has been reached.

**Booster:** A one-half wavelength long resonant metal section mounted between the converter and horn, usually having a change in cross-sectional area between the input and output surfaces. Mechanically alters the amplitude of vibration at the driving surface of the converter.

**Cal Sensor:** The menu title for accessing the calibration and verification of pressure and force.

**Cal Actuator:** Calibrate Actuator. Menus to guide the user through actuator calibration, including distance.

**Clamping force:** The pressure exerted by the horn on the workpiece.

**Cold Start:** A user operation to establish a setup to a new, initial minimum set of weld parameters. Found in the Diagnostics menu. *Warning:* Use carefully.

**Collapse Distance:** The vertical distance your part will be collapsed before termination of ultrasonics.

**Collapse Distance Graph:** A graph of collapse distance plotted against time.

**Collapse Mode:** A mode of operation in which the weld is terminated when the part has been collapsed by a user-specified distance.

**Control Limits:** An automatic weld energy compensation option. Normal weld parameters are automatically increased, up to user-defined control limits, if specified minimum weld parameters are not reached initially. Other control limit functions are Collapse Cutoff, Absolute Cutoff and Peak Power Cutoff.

**Counters:** A record of the number of cycles run by category, for example, alarms.

**Cycle Aborts:** Settings that end the cycle immediately.

**Digital Filter:** A smoothing technique used to provide more meaningful graph data.

**Downspeed:** The rate of speed of the actuator from the home position to the part.

**Energy Compensation:** Extend the weld time up to 50% greater than the weld time setting or whenever the minimum energy is reached, or shut off the weld before the expected (set) weld time if the maximum energy value is reached.

**Energy Mode:** A mode of operation in which ultrasonics are terminated at a user-specified energy value.

**External Amplitude Control:** Enables you to access real-time amplitude control directly.

**External Frequency Control:** Enables you to access real-time frequency control directly.

**Extra Cooling:** When On, allows cooling air to start when upper limit switch is triggered and remains on throughout the cycle. When Off, air is applied at ultrasonics application

**F Actual:** Actual Frequency. The operating frequency of the ultrasonic stack, as measured during a cycle.

**F memory:** Frequency as stored in Memory. The intended operating frequency value for an ultrasonic stack, stored in the memory of the power supply.

**Form Feed:** Not supported in Power Supplies manufactured since April 2025.

**Freq Chg:** Frequency Change. (Frequency at Start versus Frequency at End).

**Freq End:** Frequency at End. Frequency at the time ultrasonics was turned off.

**Freq Max:** Maximum Frequency. Highest frequency reached during weld cycle.

**Freq Min:** Minimum frequency. Lowest frequency reached during weld cycle.

**Freq Start:** Frequency at Start. Frequency at the time ultrasonics was turned on.

**Frequency Offset:** An offset factor applied to the ultrasonic frequency output set in the power supply.

**F Actual:** The actual running frequency of the acoustic system.

**F Memory:** The frequency stored in the Power Supply memory.

**General Alarm:** An alarm that occurs due to a system fault and/or tripping a limit.

**Ground Det. Cutoff:** Immediately terminates the weld process, including the hold step, when a ground detect has occurred.

**Ground Detect Mode:** In this mode of operation, ultrasonics are terminated after detection of a ground condition between the horn and fixture or anvil.

**Hold Force:** The mechanical force on the part during the Hold portion of the weld cycle.

**Hold Time:** The duration of the hold step.

**Horn Down:** A mode in which ultrasonics are locked out and the user can advance the Actuator for setup and alignment.

**Linear Encoder:** Provides carriage distance measurement during the Actuator cycle.

**X-Beam Load Cell:** Provides force measurement for accurate ultrasonic triggering and graphing of force.

**Main Menu:** The list of categories of features available in the software.

**Max Energy:** The maximum user-specified energy that produces a part without an alarm. Used with energy compensation to turn off the weld in Time mode.

**Min Energy:** The minimum user-specified energy that produces a part without an alarm. Used with energy compensation to extend the weld to up to 50% of the weld time in Time mode.

**Minus Limit:** The user-defined lower limit - used with suspect and reject limits.

**Missing Part:** A min/max distance where trigger is expected. Returns the actuator to the home position and displays an alarm indicating that the cycle was aborted because no part was present.

**Parameter range:** Valid range of parameters accepted for a particular setup.

**Password:** A user-defined access code for entry into secure areas of the user software.

**Password protection:** Enables lock-out of weld parameter modification by using a user-defined password.

**Peak Power Cutoff:** A power value that terminates the ultrasonics when peak power is not the primary control mode.

**Peak Power Mode:** A mode of operation in which ultrasonics are terminated at a user-specified power value in percentage of maximum.

**Peak Power:** A weld mode in which obtaining a power value (percentage of full power) will cause the ultrasonic energy to terminate.

**Pneumatic Air Prep:** This is a panel that mounts the cutoff valve, the slow start valve, the regulator and the two filters that are normally located in the actuator. This panel is required for installations where the actuator is not positioned in a vertical plane, or is used without a Branson actuator support.

**Post Weld Seek:** A low level (5%) amplitude running of the Power Supply after hold or afterburst for the purpose of storing a frequency to memory.

**Power Graph:** A graph of power in percentage of maximum plotted against time.

**Preset:** User-stored parameters constituting a weld setup. Saved in non-volatile memory in the power supply, can be recalled for quick Setup of the system.

**Preset name:** The ability to name a preset in customer-defined terms.

**Pretrigger:** The setting that causes ultrasonics to start before contact with the part.

**Pretrg Amp:** The amplitude at the converter during pretrigger.

**Pretrg @ D:** The distance at which pretrigger is turned on.

**Print Data/Graphs:** Not supported in Power Supplies manufactured since April 2025.

**Print on Alarm:** Not supported in Power Supplies manufactured since April 2025.

**Print on Sample:** Not supported in Power Supplies manufactured since April 2025.

**Rapid Traverse/RAPID TRAV:** Allows fast actuator descent to a user-defined point, before the Downspeed value is applied for control during the stroke.

**Ready Position:** State in which the welder is retracted and ready to receive the start signal.

**Recall Preset:** Allows a user to recall a preset from memory for purposes of operation or modification.

**Reject Limits:** User-definable limits at which the violating cycle is identified as having produced a bad part.

**Required:** State used with limits indicating that a reset will be required when the limit is exceeded. The reset is accomplished by using the reset key on the front of the Power Supply, or by external reset at the User I/O.

**Reset Required:** State used with alarms indicating that a reset will be required before a cycle can be run. The reset is accomplished by using the reset key on the front of the Power Supply, or by external reset at the User I/O.

**Run Screen:** The screen showing weld status, alarms, weld count, and process information.

**Save Preset:** Stores a programmed set of weld parameters as a preset.

**Scrub Time:** The amount of time after detection of a ground condition to the termination of ultrasonics.

**Seek:** A setting where ultrasonics are on at 5% amplitude for the purpose of finding the resonant frequency of the stack.

**Serial Port:** A RS232 port provided to you for external data communications.

**Stack:** Converter, Booster, and Horn.

**Step @ T (S):** User-definable time at which Amp A or Force A is changed to AmpB or Force B.

**Step @ E (J):** User-definable energy at which AmpA/Force A is changed to AmpB/Force B.

**Step @ Pwr (%):** User definable power at which AmpA/Force A is changed to AmpB/Force B.

**Step @ Col (in):** User-definable collapse distance at which AmpA/Force A is changed to AmpB/Force B.

**Step @ Ext Sig:** Allows you to step either Force or Amplitude based upon an external signal.

**Suspect Limits:** User-defined limits which specify weld results used to identify a part as potentially suspect, but not necessarily enough to reject the part.

**Test Scale:** The magnification of the power bar scale on the front panel while the Test key is pushed.

**Time Mode:** Terminates the ultrasonics at a user-specified time.

**Timeout:** A time at which the ultrasonic energy terminates if the main control parameter has not been reached.

**Trigger Beeper:** An audible signal sounded when the trigger is made.

**Upper limit switch (uls):** A switch when activated indicates the actuator is in the home position.

**UPS:** Power Supply module; can be either analog (AUPS) or digital (DUPS).

**User-defined limits** for process resultants, where – is the user-defined lower limit, and + is the user defined upper limit.

-/+ Energy: The energy reached during the weld.

-/+ Force: The force at the end of the weld.

-/+ Power: The peak power as a percentage of the maximum reached during the weld.

-/+ Time: The weld time reached during the weld.

-/+ Abs D: The absolute distance from the Home position reached during the weld.

-/+ Col D: The collapse distance reached during the weld.

-/+ Trg D: The position at which the trigger occurred.

**Velocity Graph:** Not supported in Power Supplies manufactured since April 2025.

**Weld Count:** Count of completed weld cycles.

**Weld Energy:** The energy specified to be applied to the part during the weld cycle.

**Weld Force:** The force at the end of the weld cycle.

**Weld History:** The last 50 weld summary data lines that are saved.

**Weld Scale:** The magnification of the power bar scale on the front panel during a weld cycle.

**Weld State:** A screen message showing the current state of the welder during or before the process. The list of messages are shown in the Run Screen section.

**Weld Summary Data:** A one-line summary of information associated with the last weld cycle.

**Weld Time:** The time for which ultrasonics are on.




---

## **Chapter 3: Delivery and Handling**

---

<b>3.1</b>	<b>Shipping and Handling</b> .....	<b>30</b>
<b>3.2</b>	<b>Receiving</b> .....	<b>31</b>
<b>3.3</b>	<b>Unpacking</b> .....	<b>32</b>
<b>3.4</b>	<b>Returning Equipment</b> .....	<b>33</b>

## 3.1 Shipping and Handling

CAUTION	
	<p>The Power Supply internal components are sensitive to static discharge. Many components can be harmed if the unit is dropped, shipped under improper conditions or otherwise mishandled.</p>

### 3.1.1 Environmental Specifications

The Power Supply is an electronic unit that converts line voltage to ultrasonic energy and controls user input for regulating the weld process. Its internal components are sensitive to static discharge, and many of its components can be harmed if the unit is dropped, shipped under improper conditions, or otherwise mishandled.


The following environmental guidelines should be respected in the shipping of the Power Supply.

**Table 3.1** Environmental Specifications

Environment	Range
Ambient Operating Temperature	+41°F to +122°F (+5°C to +50°C)
Storage / Shipping Temperature	-13°F to +158°F (-25°C to +70°C)
Shock / Vibration (transit)	40 g shock / 0.5 g and (3-100 Hz) vibration per ASTM 3332-88 and 3580-90
Humidity	30% to 95%, non-condensing

## 3.2 Receiving

The Power Supply is a sensitive electronic device. Many of its components can be harmed if the unit is dropped or otherwise mishandled.

CAUTION	
	The Actuator and the Power Supply are heavy. Handling, unpacking, and installation might require assistance or the use of a lifting device.


### Scope of Delivery


Branson Power Supply units are carefully checked and packed before dispatch. It is recommended, however, that you follow the inspection procedure below after delivery.

To inspect the Power Supply when it is delivered, take the following steps:

**Table 3.2** Inspecting the Power Supply upon delivery

Step	Action
1	Verify that all parts are complete according to the packing slip.
2	Check the packing and the unit for damage (visual inspection).
3	Report any damage claims to your carrier immediately.
4	Determine if any component has become loose during shipping and, if necessary, tighten screws.

NOTICE	
	If the goods delivered have been damaged during shipping, please contact the forwarding agent immediately. Retain packing material (for possible inspection or for sending back the unit).

CAUTION	
	The Actuator and the Power Supply are heavy. Handling, unpacking, and installation may require the assistance of a colleague or the use of lifting platforms or hoists.

## 3.3 Unpacking

The Power Supply is fully assembled. It is shipped in a sturdy cardboard box. Some additional items are shipped in the box with the Power Supply.

When unpacking the Power Supply, take the following steps:

**Table 3.3** Unpacking the Power Supply

Step	Action
1	Unpack the Power Supply as soon as it arrives. Save the packing material.
2	Inspect the controls, indicators, and surface for signs of damage.
3	Remove the cover of the Power Supply ( <a href="#">7.7: Parts Replacement</a> ) to check if any components became loose during shipping.
<b>NOTICE</b> If damage has occurred, notify the shipping company immediately. Retain packing materials for inspection.	
4	Store or ship the Power Supply only within a temperature range of -22°F to +158°F (-25°C to +70°C).

### 3.4 Returning Equipment

If you are returning equipment to Branson Ultrasonic Corporation, please call your Customer Service Representative to receive approval to return goods to Branson.

If you are returning equipment for repair refer to [Chapter 1: Safety and Support](#), Section [1.5: Returning Equipment for Repair](#), of this manual, for appropriate procedure.



---


## **Chapter 4: Installation and Setup**

---

<b>4.1</b>	<b>About Installation . . . . .</b>	<b>36</b>
<b>4.2</b>	<b>Handling and Unpacking . . . . .</b>	<b>37</b>
<b>4.3</b>	<b>Take Inventory of Small Parts. . . . .</b>	<b>41</b>
<b>4.4</b>	<b>Installation Requirements. . . . .</b>	<b>43</b>
<b>4.5</b>	<b>Installation Steps . . . . .</b>	<b>48</b>
<b>4.6</b>	<b>Start Switch Connection (Automation) . . . . .</b>	<b>55</b>
<b>4.7</b>	<b>Guards and Safety Equipment. . . . .</b>	<b>64</b>
<b>4.8</b>	<b>Rack Mount Installation . . . . .</b>	<b>65</b>
<b>4.9</b>	<b>Assemble the Acoustic Stack. . . . .</b>	<b>67</b>
<b>4.10</b>	<b>Installing the Ultrasonic Stack in the Actuator. . . . .</b>	<b>72</b>
<b>4.11</b>	<b>Testing the Installation. . . . .</b>	<b>75</b>
<b>4.12</b>	<b>Still Need Help? or Parts? Have Questions? . . . . .</b>	<b>76</b>

## 4.1 About Installation

This chapter is intended to help the installer with the basic installation and setup of your new 2000-series welder. This chapter will bring the reader to the point at which the system is functionally “ready to weld”.

CAUTION	
	The Actuator and related components are heavy. Handling, unpacking, and installation can require help or the use of lifting platforms or hoists.

International safety labels are found on the power supply and the actuator as well. Those that are of importance during Installation of the system are identified in the figures in this and other chapters of the manuals.

## 4.2 Handling and Unpacking

If there are any visible signs of damage to the shipping containers or the product, or you later discover hidden damage, NOTIFY YOUR CARRIER IMMEDIATELY. Save the packing material.

1. Unpack the 2000-series components as soon as they arrive. Refer to the following procedures.
2. Verify you have all of the equipment ordered. Some components are packed inside other boxes.
3. Inspect the controls, indicators, and surfaces for signs of damage.
4. Save all packing material, including the pallets and wood spacer blocks.

### 4.2.1 Unpack the Power Supply

Power supplies are shipped in a cardboard carton. It weighs approximately 40 lbs.

1. Open the box, remove the two foam top packing halves and lift the power supply out.
2. Remove the toolkit(s) and other components shipped with the power supply. These items may be shipped in small, separate boxes, or underneath the power supply in the box.
3. Save the packing material; evaluation systems will be returned using this packing material.


### 4.2.2 Unpack the Stand or Actuator

The stand (or actuator) is heavy and packed in a protective shipping container. The actuator toolkit is packed with the actuator. A booster, converter and other components may be packed inside the shipping container (depending on the equipment ordered).

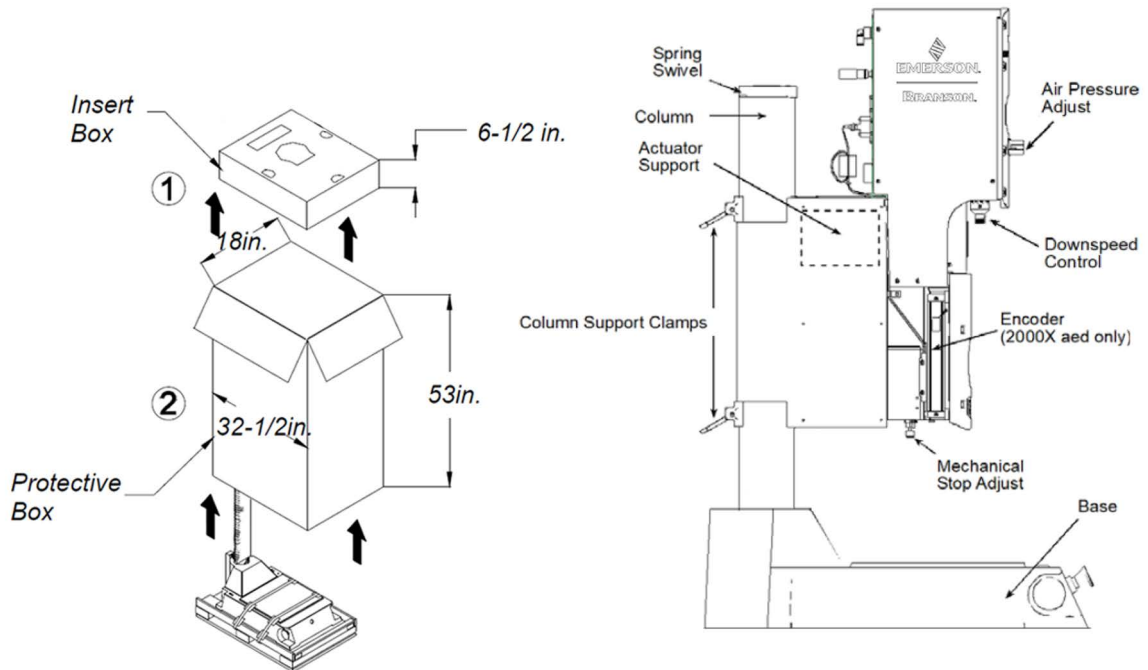
- Stands are shipped on a wooden pallet with a cardboard box cover
- Actuators (alone) are shipped in a rigid cardboard box using protective foam shells for support

Depending on which one of the following options applies to you, unpack the Branson actuator assembly:


### 4.2.3 Stand (actuator on a base)

CAUTION	
	<p>Heed the "This End Up" arrows and the "Open Top First" instructions. The packaging is designed to be removed from the assemblies from an upright orientation only.</p>

**Figure 4.1** Unpacking the Stand (Actuator on a Base); left-side view of Stand



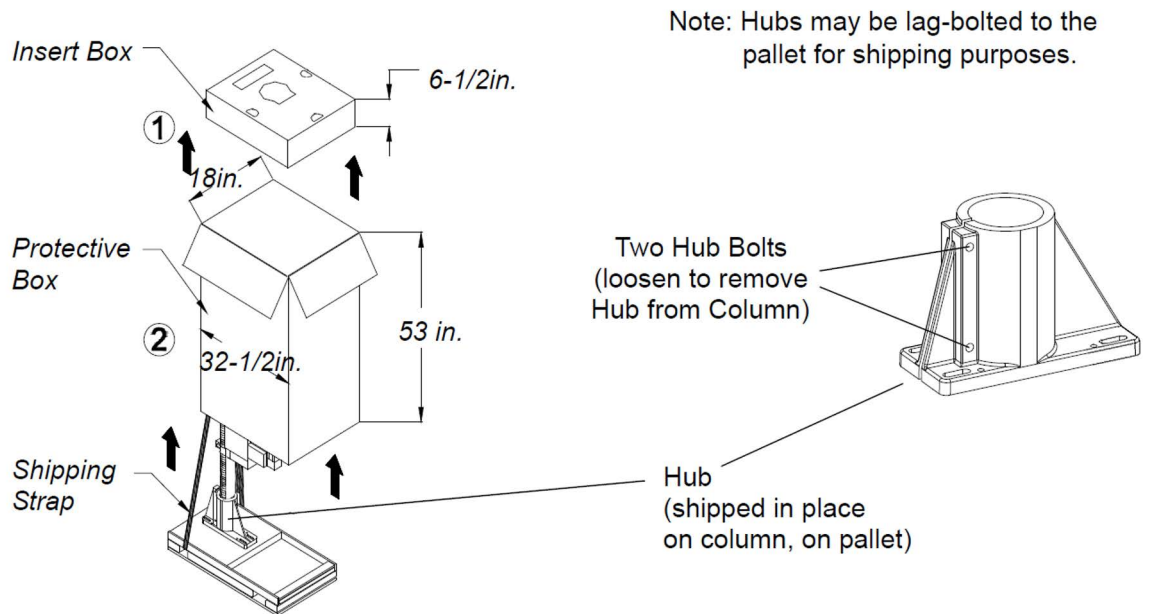
1. Move the shipping container close to the intended installation location, leave it on the floor.
2. Open the top of the box. Remove the insert from the top of the protective box.
3. Remove the staples at the bottom of the protective box. Lift the protective box off the pallet.


CAUTION	
	<p>The column and column support are under spring tension from the counterbalance spring. Do NOT attempt to disassemble the column from the stand, but always keep the column support clamped together. When making height adjustments, carefully and slowly release the clamps to control the motion, and hold the stand to prevent sudden movements or injury.</p>

4. Cut the two packing straps around the base and pallet. Pry off the two wooden shipping blocks (to the rear of the base) which prevent the base from sliding on the pallet.
5. The stand can now be moved into its desired location by sliding it off the pallet. Stands have a lifting hook for the use of overhead hoists to lift the assembly in place.
6. Remove the block of wood between the base and the column support by carefully loosening the two column clamps (allowing the actuator to rise slightly, but not allow sudden movements) and then cutting the shipping tape on the block of wood. **RETIGHTEN THE COLUMN CLAMPS.**
7. Unpack the toolkit from the insert box, and other parts (converter, booster, cables, manuals, etc.) that may have shipped with the stand. Save the packing material.
8. Go to **Take Inventory of Small Parts.** See [Table 4.1](#).


## 4.2.4 Stand (Actuator on a Hub)

**Figure 4.2** Unpacking the Stand (Actuator on a Hub); Hub shown separately




CAUTION	
	<p>Heed the "This End Up" arrows and the "Open Top First" instructions. The packaging is designed to be removed from the assemblies from an upright orientation only.</p>

1. Move the shipping container close to the intended installation location, leave it on the floor.
2. Cut the two vertical packing straps, and open the top of the box. Remove the insert from the top of the box. Set the insert box aside.
3. Remove the staples at the bottom of the protective box. Lift the protective box off the pallet. Flatten the box and lay it next to the pallet (you will lay the stand on it soon).

CAUTION	
	<p>The unit may tend to tip over. Stabilize the stand using the lifting hook or an assistant.</p>

4. Cut the packing strap securing the column support to the pallet.

CAUTION	
	<p>The column and column support are under spring tension from the counterbalance spring. Do NOT attempt to disassemble the column from the stand, but always keep the column support clamped together. When making height adjustments, carefully and slowly release the clamps to control the motion, and hold the stand to prevent sudden movements or injury.</p>


5. Remove the block(s) of wood between the base and the support by slowly loosening the two column clamps (allowing the stand to rise slightly) and then cutting the shipping tape on the block of wood. **RETIGHTEN THE COLUMN CLAMPS.**
6. Loosen the two hub bolts (for column clamping) on the hub.
7. Remove the hub from the pallet and set it aside. Some hubs are bolted to the pallet from the top.
8. Unpack the converter, booster, cables, manuals, toolkit, and insert box. Save the packing material, including the blocks of wood.
9. Go to [Take Inventory of Small Parts](#). See [Table 4.1](#).

## 4.2.5 Actuator (alone)

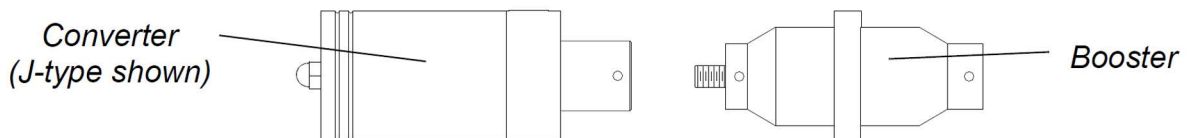
The actuator, if shipped alone, is assembled and ready to install.

Move the shipping container close to the intended installation location, leave it on the floor.

1. Open the top of the cardboard box, remove the insert from the top of the box and set it aside.
2. The toolkit, mounting bolts, converter and/or booster, manuals and cables as ordered, are shipped with the actuator. Unpack the converter, booster, toolkit and bolts from their packages.
3. Save the packing material.

NOTICE	
	<p>The packaging may also include the converter and/or booster, if ordered.</p>

**Figure 4.3** Ultrasonic Converter (J-Type for stand use) and Booster



## 4.3 Take Inventory of Small Parts

**Table 4.1** Small Parts Included (=x) with Power Supply and/or Actuator Assemblies

Part or Kit	2000 Power Supply				Actuator		
	15 kHz	20 kHz	30 kHz	40 kHz	Stand (Base)	Stand (Hub)	(alone)
T-Handle Wrench	X				X	X	X
Mylar Washer Kit	X	X	X				
Silicone Grease				X			
Actuator Mtg. Bolts							X
15 kHz Spanners (2)	X						
20 kHz Spanners (2)		X					
30 kHz Spanners (2)			X				
40 kHz Spanners (2)				X			
40 kHz Sleeve					ordered part	ordered part	ordered part
40 kHz Sleeve Spanner					ships w/ Sleeve	ships w/ Sleeve	ships w/ Sleeve
Fixture Bolts and Washer					X		
M8 Allen Wrench					X		
5/64" Allen Wrench							

### 4.3.1 Cables

Two cables connect the power supply and actuator: the actuator interface cable, and the RF cable. If the system is to be automated, you may also need a J911 start cable and a user I/O cable. Check your invoice for cable types and cable lengths.

**Table 4.2** List of Cables

EDP Number	Description
101-241-202	Remote Pneumatic (RP) Package Cable (J924), 8'
101-241-203	Actuator Interface, 8' (J925S)
101-241-204	Actuator Interface, 15' (J925S)
101-241-205	Actuator Interface, 25' (J925S)
101-241-206	Actuator Interface, 50' (J925S)
101-241-207	Alarm I/O, 8' (J957S)

**Table 4.2** List of Cables


EDP Number	Description
101-241-208	Alarm I/O, 15' (J957S)
101-241-209	Alarm I/O, 25' (J957S)
101-241-258	Alarm I/O, 50' (J957S)
101-240-020R	Start Cable (J911) 8' (req PLA)
101-240-015R	Start Cable (J911) 15' (req PLA)
101-240-010R	Start Cable (J911) 25' (req PLA)
101-240-168R	Start Cable (J911) 50' (req PLA)
101-240-072R	Start Cable (J913) 25' (no PLA req)
101-240-017	RF, non-CE - 8' (J931S)
101-240-012	RF, non-CE - 15' (J931S)
101-240-007	RF, non-CE - 25' (J931S) <b>Note:</b> Not for 30 kHz or 40 kHz systems
101-240-200	RF, non-CE - 50' (J931) <b>Note:</b> Not for 30 kHz or 40 kHz systems
101-240-034	RF, non CE - 8' (J 934)
101-240-035	RF, non CE - 15' (J934)
101-240-081	RF, non CE - 8' (J936S)
101-240-069	RF, non CE - 15' (J936S)
101-240-080	RF, non CE - 25' (J936S)
101-240-176	RF, CE - 8' (J931CS)
101-240-177	RF, CE - 15' (J931CS)
101-240-178	RF, CE - 25' (J931CS) <b>Note:</b> Not for 30 kHz or 40 kHz systems
101-240-297	CBL EXT 36' RF J931C CE
101-240-199	RF, CE - 50' (J931C)
101-240-179	RF, CE - 8' (J934C)
101-240-181	RF, CE - 15' (J934C)
101-240-182	RF, CE - 20' (J934C)
100-246-630	Ground Detect Cable

## 4.4 Installation Requirements

This section covers the location options, dimensions of the major assemblies, environmental requirements, electrical requirements and factory air requirements, to help you plan and execute your installation successfully.

### 4.4.1 Location

The actuator or stand may be installed in a variety of positions. The stand (on a base) is often manually operated, using its base-mounted start switches, and so is installed at a safe and comfortable workbench height (approximately 30-36 inches) with the operator sitting or standing in front of the system. Stands (on hubs) are often used in automated systems and may be manually or automatically loaded and unloaded.

WARNING	
	<p>The stand may tip over if moved around the axis of its column, if not properly secured. The work surface on which a stand is installed must be sturdy enough to support it, and secure enough to not tip over when the stand is adjusted during installation or setup.</p>

The power supply may be located up to 50 feet away for 20 kHz, (20' for 30 kHz, and 15' for 40 kHz models) from the actuator. The power supply must be accessible for user parameter changes and settings, and must be placed in a horizontal orientation. The power supply should be positioned so it does not draw in dust, dirt or material via its rear fans. Refer to the illustrations on the pages that follow for a dimensional drawing of each component. All dimensions are approximate and may vary between models:

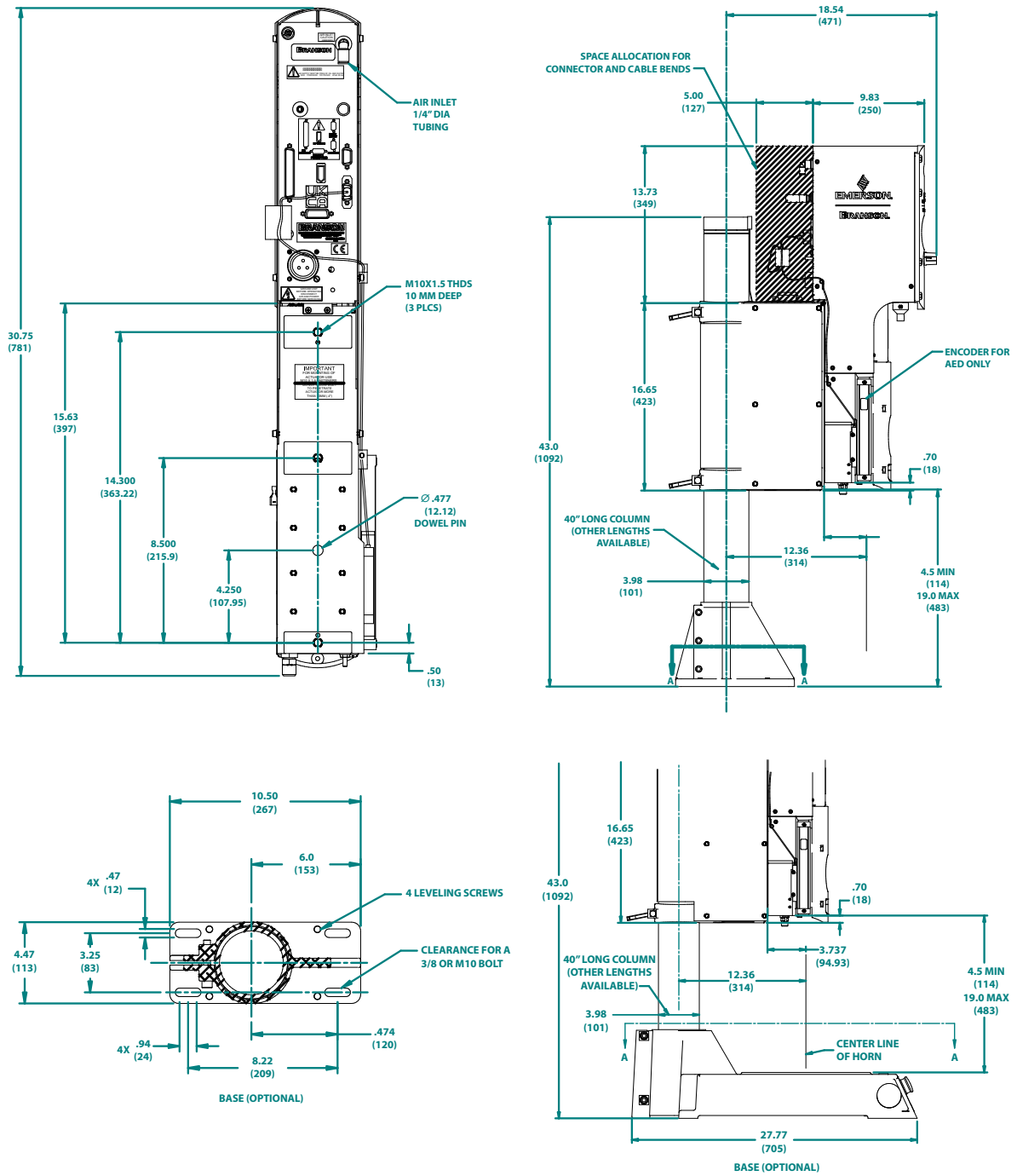
[Figure 4.4 ae Actuator Dimensional Drawing](#)

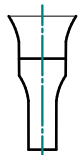
[Figure 4.5 Power Supply Dimensional Drawing](#)

[Figure 4.6 Base Mounting Centers](#)

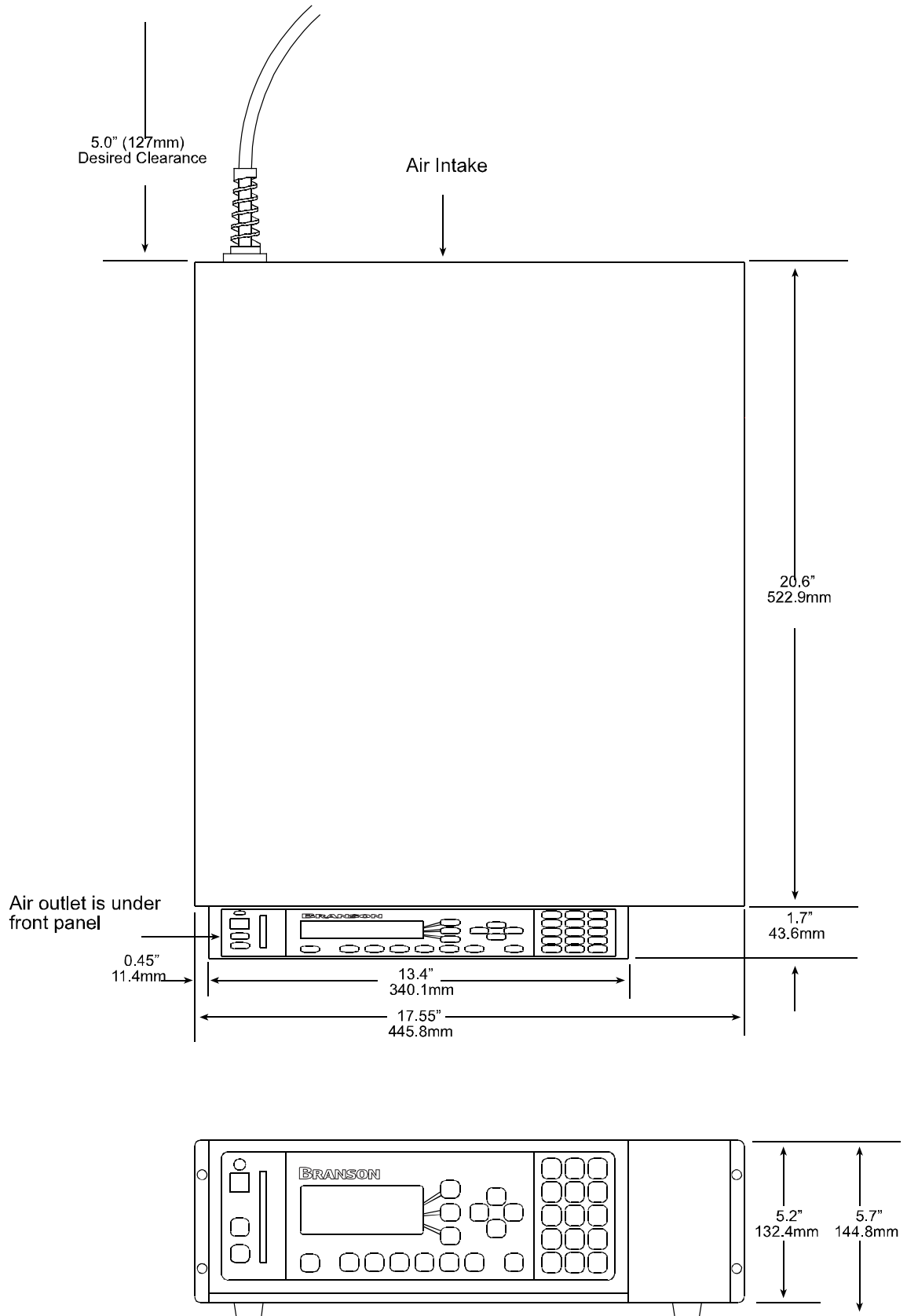
[Figure 4.7 Mounting Bolt Pattern for the Hub \(for Stand on Hub\)](#)

**Figure 4.4** ae Actuator Dimensional Drawing



HORN DIMENSIONS	FREQUENCY			DIMENSION SHOWN ARE APPROXIMATE TO ALLOW FOR DIFFERENT BOOSTER GAIN HORN DESIGN, MATERIAL AND TUNING. ALL HORN DIMENSIONS ARE FOR 1/2 WAVE DESIGNS. ALLOW FOR ADJUSTABILITY AND POTENTIAL TOOLING CHANGE.
	20 KHz	30 KHz	40 KHz	
 <p>HORN WIDTH AND LENGTH WILL VARY WITH EACH DESIGN</p>	2.12 TO 2.75	1.30 TO 1.54	0.69 TO 0.94	
	5 TO 5.50	2.97 TO 3.80	2.5 TO 2.75	

**Figure 4.5** Power Supply Dimensional Drawing



## 4.4.2 Environmental Specifications

**Table 4.3** Environmental Specifications

Environmental Concern	Acceptable Range
Humidity	30% to 95%, non-condensing
Ambient Operating Temperature	+5°C to +50°C (41°F to 122°F)
Storage / Shipping Temperature	-25°C to +55°C (-13°F to +131°F); Up to +70°C (+158°F) for 24 hours

## 4.4.3 Electrical Input Power Ratings

Plug the Power Supply into a single-phase, grounded, 3-wire, 50 or 60 Hz power source. [Table 4.4](#) lists the current and fuse ratings for the various models.


**Table 4.4** Input Power Requirements

Model	Power	Current Rating	NEMA Connector
20 kHz	1250 W 200V - 240V	7 Amp Max. @ 200V / 20 Amp fuse	NEMA L6-20P Plug
	1250 W 100V - 120V	14 Amp Max. @ 100V / 20 Amp fuse	NEMA 5-15P Plug
	2500 W 200V - 240V	14 Amp Max. @ 200V / 20 Amp fuse	NEMA L6-20P Plug
	4000 W 220V - 240V	25 Amp Max. @ 220V / 25 Amp fuse	*
30 kHz	750 W 100 - 120V	10 Amp Max. @ 100V / 20 Amp fuse	NEMA 5-15P Plug
	750 W 200 - 240V	5 Amp Max. @ 200V / 20 Amp fuse	NEMA L6-20P Plug
	1500 W 200V - 240V	10 Amp Max. @ 200V / 20 Amp fuse	NEMA L6-20P Plug
40 kHz	400 W 200V - 240V	3 Amp Max. @ 200V / 20 Amp fuse	NEMA L6-20P Plug
	400 W 100V - 120V	5 Amp Max. @ 100V / 20 Amp fuse	NEMA 5-15P Plug
	800 W 200V - 240V	5 Amp Max. @ 200V / 20 Amp fuse	NEMA L6-20P Plug
	800 W 100V - 120V	10 Amp Max. @ 100V / 20 Amp fuse	NEMA 5-15P Plug

\*To be hardwired by customer.

#### 4.4.4 Factory Air

The factory compressed air supply must be “clean (to a 5 micron level), dry and unlubricated” air with a regulated maximum pressure of 100 psig (690 kPa). Depending on your application, the actuator requires between 35 to 100 psi. Stands include an in-line air filter. Actuators (alone) require a customer-provided air filter. A quick-disconnect fitting is suggested. Use a lockout device on the air line if required.

WARNING	
	<p>Synthetic air compressor lubricants containing Silicone or WD-40 will cause internal actuator damage and failure due to the solvents contained within these types of lubricants.</p>

##### 4.4.4.1 Air Filter

Actuators (alone) require a customer-provided air filter which protects from particulate matter of 5 microns or larger. If a stand is mounted in a position other than upright (vertical), each air filter must be relocated and oriented so its bowl is the lowest point, and the air flow across the air filter is horizontal. This may require some re-plumbing of the existing equipment at the customer site. The air filter is held in place by two screws on a bracket bolted to the column support, and by the factory-installed tubing. For further information, see your Actuator manual.


##### 4.4.4.2 Pneumatic Tubing and Connectors


Actuator assemblies are not externally plumbed from the factory, but provide conventional 1/4-inch OD pneumatic tubing connection at the air inlet. If making connections for an actuator, or if re-plumbing your system for a new air filter location, you must use 1/4-inch OD tubing and connectors rated above 100 psi (use “Imperial Eastman Poly-Flo Tubing 44-P-1/4” or equivalent, and appropriate connectors). Refer to Actuator manual.

##### 4.4.4.3 Pneumatic Connections to Actuator Xae/Xaed

Air connection to the actuator is made to the AIR INLET connector on the top rear of the actuator, with plastic pneumatic tubing. For installations using actuator-alone assemblies, you must provide an air filter assembly which will support at least to 100 psig and remove particulate matter of 5 microns or larger.


## 4.5 Installation Steps

WARNING	
	<p>This product is heavy and can cause a pinching or crushing injury during installation or adjustment. Keep clear of moving parts and do not loosen clamps unless directed to do so.</p>

CAUTION	
	<p>If a stand is not mounted in a vertical position, the air filters (on the column support) must be removed, reoriented, and replumbed. Failure to do so can cause air filter failure, and actuator failures.</p>

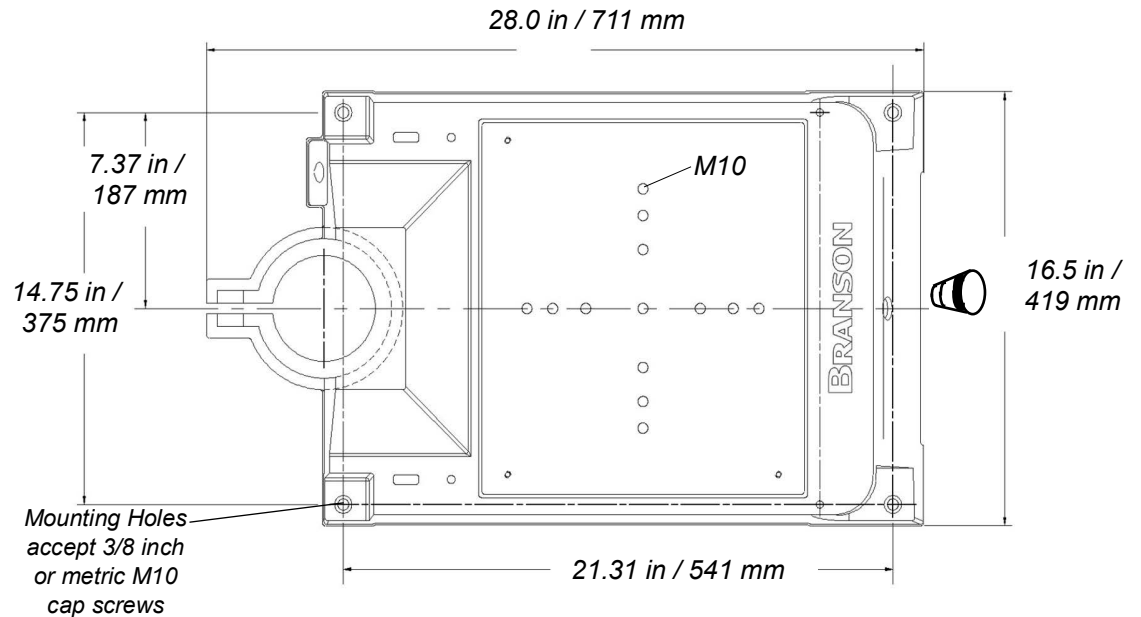
### 4.5.1 Mounting the Stand (Actuator on Base)

The base must be bolted to your workbench to prevent tipping or undesired movement. Four mounting bolt holes are provided at the corners of the casting, and will accept your 3/8 inch or M10 cap screws. Use flat washers against the metal casting to prevent gouging. Refer to [Figure 4.6](#).

CAUTION	
	<p>You must secure the base to your work surface using four bolts, to prevent tipping or undesired movement, in the event the actuator is moved off-center or rotated around the column.</p>


1. Ensure there are no overhead obstructions and that no pinch or rub points exist. Remember that the actuator is taller than the column when fully raised, and there are exposed connections.
2. Mount the base to your workbench using four socket-head cap screws (customer provided, 3/8 inch (US bases) or M10 (metric bases)). Use flat washers against the metal casting to prevent gouging. The use of nylon lock nuts with your cap screws is suggested, to reduce loosening due to vibration and movement.
3. Connect factory air to the air hose on the stand (3/8 NPT male fitting on the hose). A quick-disconnect fitting is suggested. Use a lockout device on the air line if required.
4. Verify the base/start switch control cable is properly connected to the **back of actuator**.
5. Verify the linear encoder connector is properly connected to the **back of the actuator**.

**Figure 4.6** Base Mounting Centers

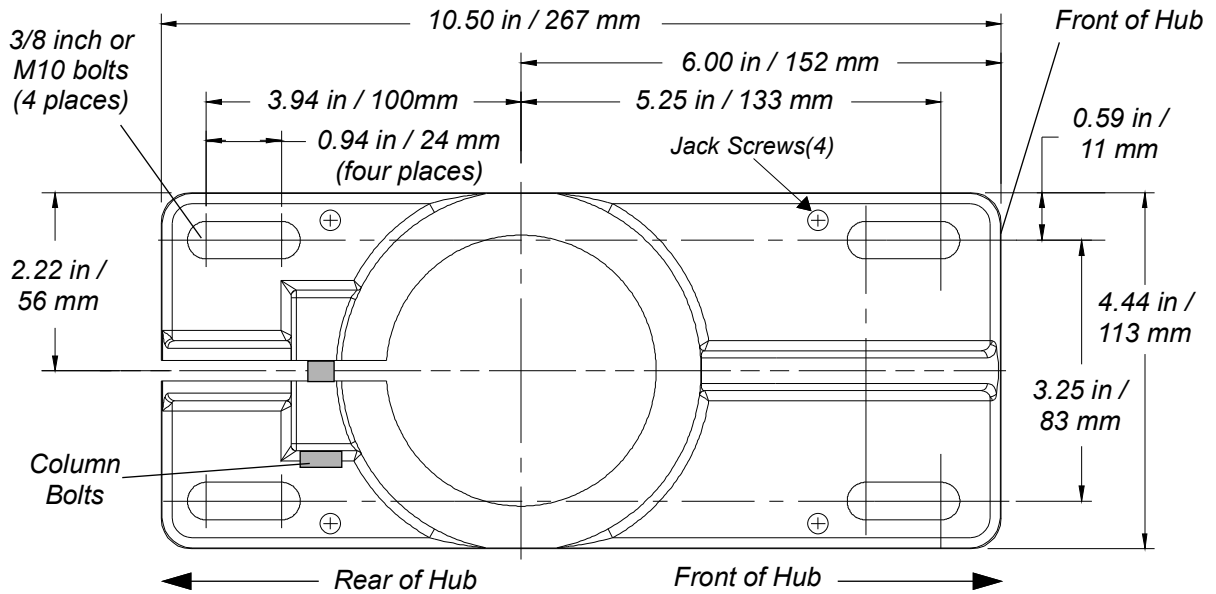


## 4.5.2 Mounting the Stand (Actuator on Hub-mounted column)


During unpacking, you removed the hub from the column/stand assembly. You must choose a mounting location for the hub that will support the column and actuator, and provide the hardware to mount it. Four mounting bolt holes are provided at the corners of the casting, and will accept your 3/8 inch or M10 hardware. Use flat washers against the metal casting to prevent gouging. Refer to [Figure 4.7](#).

CAUTION	
	<p>The hub must be installed with its front in the same direction as the front of the actuator. The column bolts of the hub are found on the rear of the hub. See <a href="#">Figure 4.7</a> for mounting details.</p>

**Figure 4.7** Mounting Bolt Pattern for the Hub (for Stand on Hub)



1. Locate the hub in the desired location. Ensure no overhead or side obstructions will interfere with normal operation or use of the system.


CAUTION	
	<p>Mount the hub to your work surface using four bolts, 3/8-inch or M10 shank size, with flat washers against its metal casting (customer provided hardware).</p>


2. Carefully lift the actuator and column assembly, and mount the column in the hub. Align the flat face of the spring swivel with the top-front of the actuator. Tighten the two bolts on the hub.
3. Connect factory air to the air hose on the stand (3/8 NPT male fitting on the hose). A quick-disconnect fitting is suggested. Use a lockout device on the air line if required.
4. Verify the base/start switch control cable is properly connected to the **back of actuator**.
5. Verify the linear encoder connector is properly connected to the **back of the actuator**.
6. Use jack screws to fine adjust the system level. A 3/16" allen wrench should be used for the 3/8"-16 x 3/4" jack screws.

### 4.5.3 Actuator (alone)

The actuator (alone) is intended for installation on your custom-made mounting support. It is located in place with a mounting pin and secured using three metric bolts which are provided with the actuator.

1. Lift the actuator from the box. Carefully lay the assembly on its right side (NOT on the side with the linear encoder).

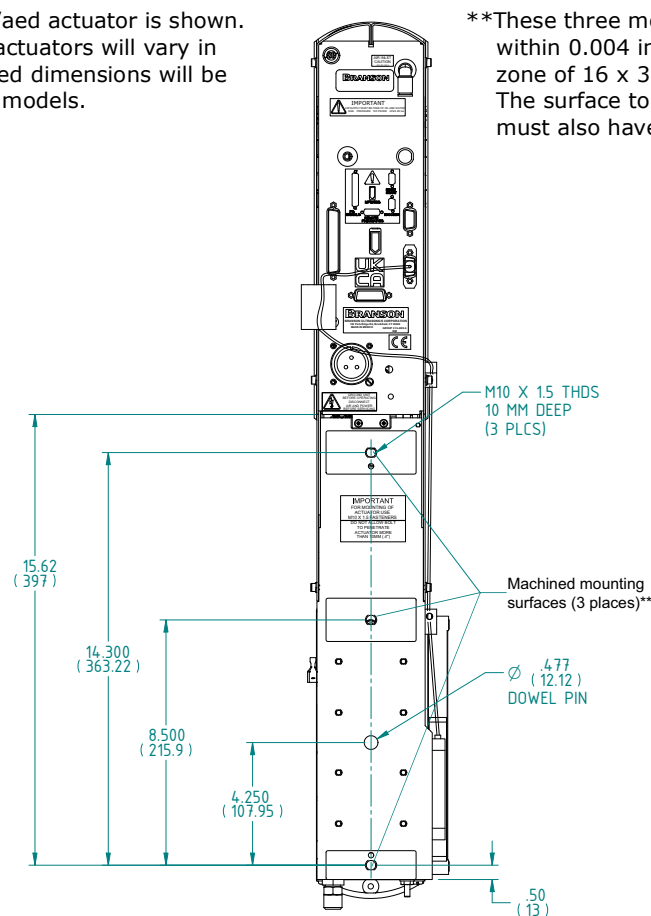
CAUTION	
	<p>The actuator support bolts for the 2000-Series actuators are metric, M10 x 1.5 thread pitch, 25mm long. The support pin and mounting bolts must not extend more than 0.40 in (10 mm) into the actuator, otherwise, binding or damage to the carriage may occur.</p>

CAUTION	
	<p>DO NOT use 900-Series M10 x 1.25 mounting bolts. They have a different thread pitch and will not interchange with those used on the 2000-Series.</p>

- Use of a guide pin is suggested. It is not provided with the actuator. If you require a guide pin, use a solid metal dowel pin, 12mm diameter, which must not extend into the actuator more than 0.40 inch (10mm) from your support.


**Figure 4.8** Actuator Rear View, Mounting Surface, Bolt and Guide Pin Locations

Rear view of ae/aed actuator is shown. Although other actuators will vary in height, referenced dimensions will be the same for all models.



\*\*These three mounting surfaces are flat within 0.004 in. (0.1mm) TIR, in a tolerance zone of 16 x 3.5 in. (410 x 90 mm). The surface to which the actuator is mounted must also have the same flatness tolerance.

- Lift the actuator assembly into position on your mount, and secure using the metric bolts provided.

CAUTION	
	<p>In the event you must use bolts of a different length, ensure that the bolts extend more than 0.25 inch (6 mm) into the threads in the actuator housing, but less than 0.40 inch (10 mm).</p>

## 4.5.4 Mount the Power Supply

The power supply is designed to be placed on a workbench (rubber feet on bottom) within cable-length limits of the actuator, or it may be rack-mounted in a standard 19-inch Rack (using an optional rack mount handle kit). It has two rear-mounted fans which draw cooling air from rear to front, which must be free from obstruction. Do not place the power supply on the floor or in other locations that will allow dust, dirt or contaminants to be drawn into the power supply.

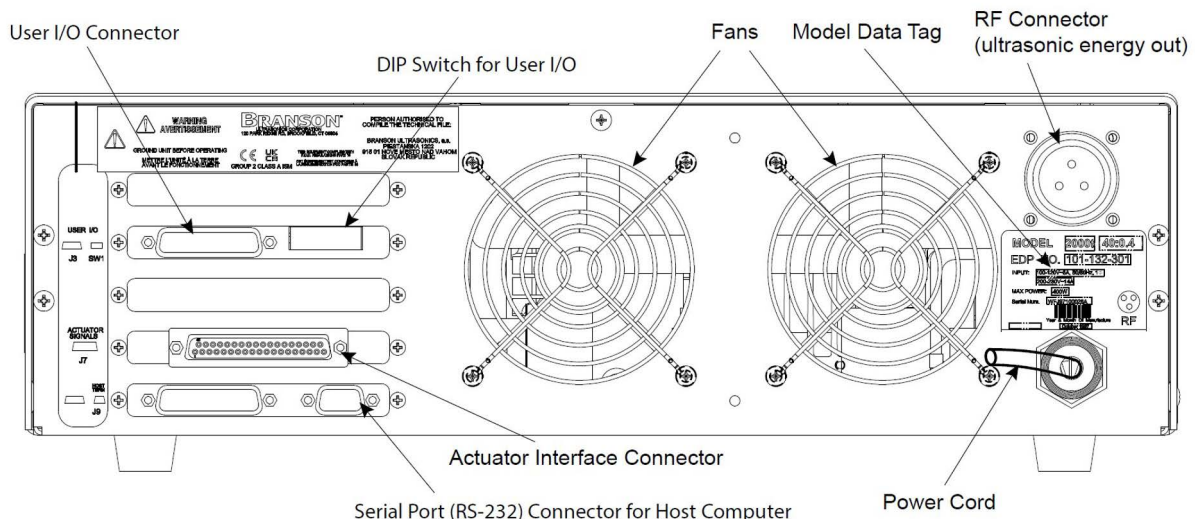
The controls on the front of the power supply must be accessible and readable for setup changes.

All electrical connections are made to the rear of the power supply, which should be positioned in your workspace with adequate clearance (approximately 4 inches or more on either side, and 6 inches to the rear) for cable access and ventilation. Do not place anything on top of the power supply case.

See [Figure 4.5 Power Supply Dimensional Drawing](#) for a dimensional drawing of the 2000 Power Supply.

## 4.5.5 Interconnect between Power Supply and Actuator

**Figure 4.9** Connections on Rear of Power Supply



The cable lengths are limited because of the amount and type of power and control being delivered to the remainder of the system. Performance and results can suffer if the RF cable is crushed, pinched, damaged or modified. Contact your Branson Representative if

you have special cable requirements. In some cases, remote operation from a User I/O or a Host Computer can be used to solve a distance limitation.


#### 4.5.6 Input Power (Main)

The system requires single-phase input power, which you connect to the Power Supply using the integral power cord. See [Table 4.4 Input Power Requirements](#) for plug and receptacle requirements for your specific power level.

Refer to the unit's Model Data Tag to be sure of the power rating of the Model in your system.

#### 4.5.7 Output Power (RF Cable)

Ultrasonic Energy is delivered to a screw-on receptacle connection on the rear of the Power Supply, which is connected to the Actuator or the Converter (depending on your application).

WARNING	
	<p>Never operate the System with the RF Cable disconnected or if the RF Cable is damaged.</p>

#### 4.5.8 Interconnect between Power Supply and Actuator

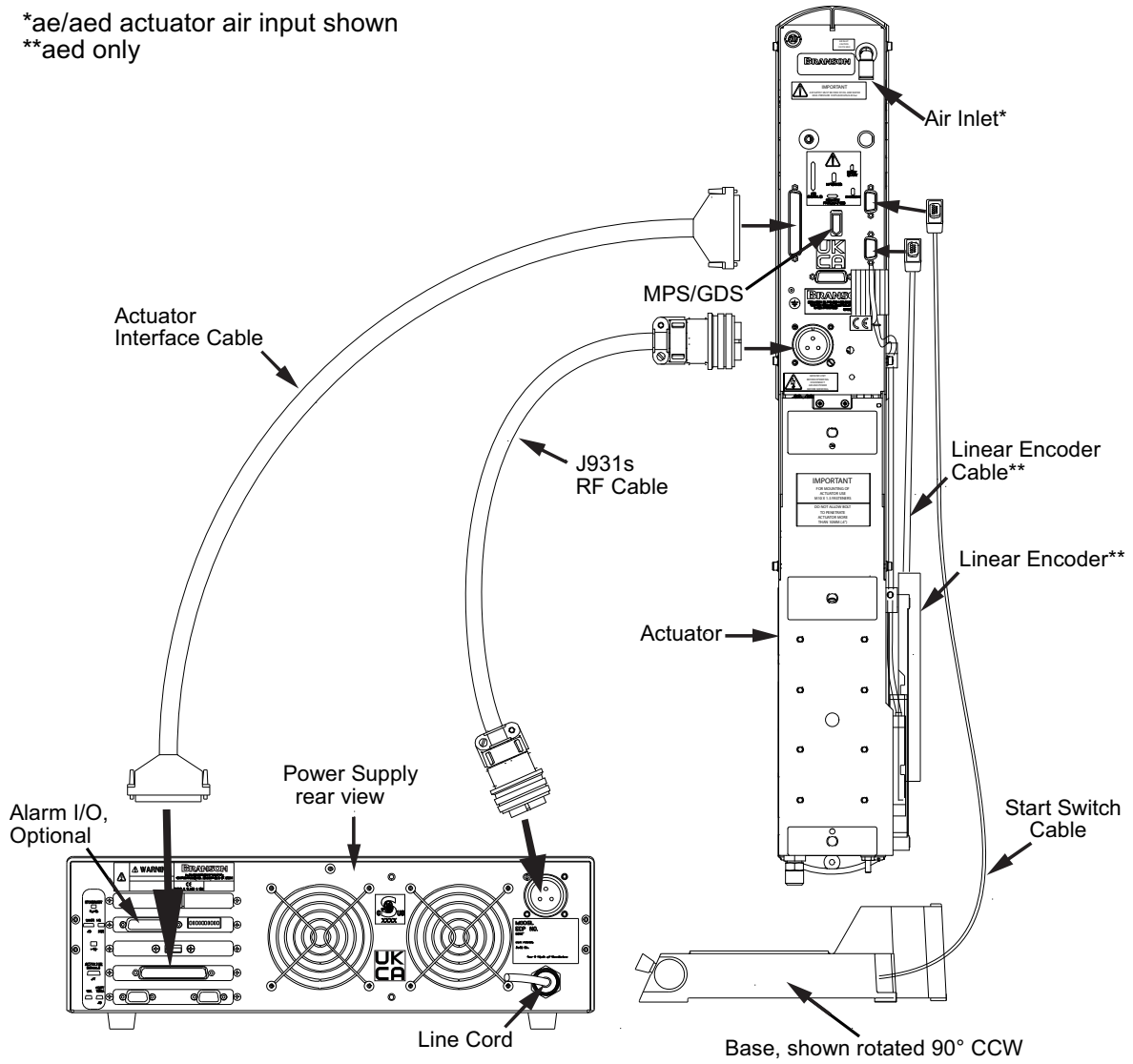
If using a Branson 2000-series Actuator, there are two electrical connections between the Power Supply and the Actuator: the RF Cable and the Actuator Interface cable. A 37-pin cable is used for Power and Control Signaling between the 2000X ea Power Supply and a Branson Actuator. The cable connects to the rear of the Power Supply and the rear of the Actuator. Refer to [Figure 4.9 Connections on Rear of Power Supply](#) for clarification of connections on rear of power supply.

There can be other connections to the Actuator, and other connections to the Power Supply, but these are the only two standard connections, depicted in [Figure 4.11](#).


For ground detect use, to have ultrasonic energy turn off when the horn comes in contact with your electrically isolated fixture or anvil, it is necessary to install Branson cable EDP No. 100-246-630 from the MPS/GDS receptacle on the rear of the actuator to your isolated fixture/anvil in order to utilize this feature.

**Figure 4.10** Electrical Connections from Power Supply to a 2000-series Actuator

\*ae/aed actuator air input shown  
\*\*aed only

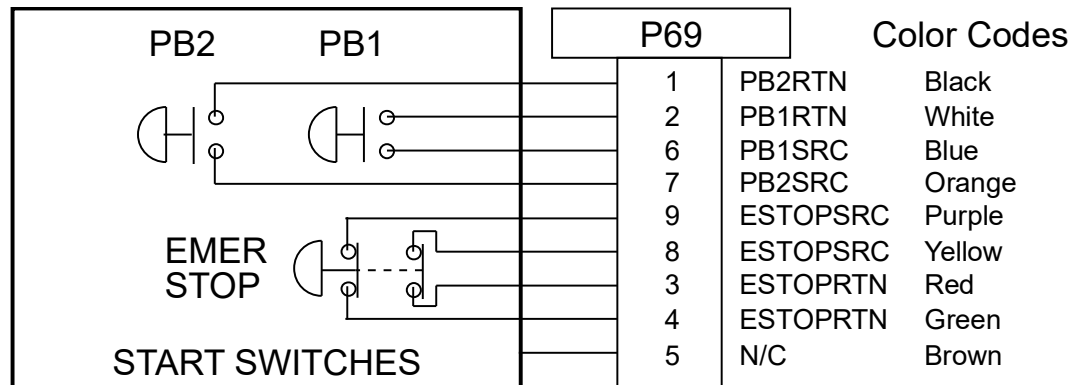



## 4.6 Start Switch Connection (Automation)


NOTICE	
	<p>See <a href="#">Appendix A: Automation</a> for additional information about Automation.</p>

A Branson actuator requires 2 start switches and emergency stop connection. Stands on a base include this connection (factory installed and connected from the base) while the stand on a hub and actuator (alone) applications require the user make their own start switch/E-stop connections, as follows:

**Figure 4.11** Start Switch Connection Codes



NOTICE	
	<p>Solid state devices may be used in lieu of mechanical start switches providing their leakage current does not exceed 0.1mA.</p>

NOTICE	
	<p>Start Switches PB1 and PB2 must be closed within 200 milliseconds of each other, and remain closed until the WELD ON signal is active, to effect a start condition.</p>

BASE/START is the DB-9 female connection on the back of the actuator. Your cable requires a male DB-9 (D-shell) connector.

PB1 and PB2 are two normally open start-switches which must be operated simultaneously to start the welding cycle. These must be closed within 200 milliseconds of each other, or error message: "Start Sw Time" will display. This doesn't require a reset, but for the next cycle, switches must be within time limit to preclude re-occurrence of error message. Refer to Note above.

EMER STOP is an emergency stop switch, normally closed.

## 4.6.1 Serial (RS-232) Port Connector

An RS-232c serial port (DB-9 format) is provided for the Host Computer option. Only three data leads of this port are supported at this time (Data Send TXD, Data Receive RXD, and Signal Ground GND). The remainder of the leads are 'reserved'. A null modem cable is required.

The comport parameters are fixed, can not be altered or viewed in the menu.

The fixed values are:

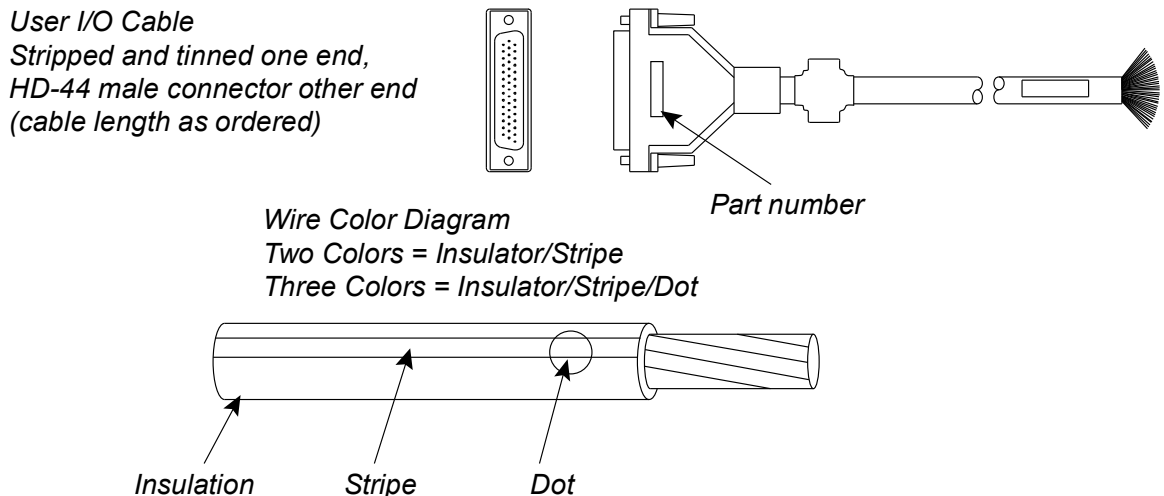
1. com speed = 9600 baud
2. no parity
3. 1 stop bit
4. 8 data bits

## 4.6.2 User I/O Interface

The user I/O is a standard interface for automation, provided on the power supply. It provides the ability for the customer to make their own interface for their automation or special control or reporting needs. The interface cable has an HD44 female D-shell connection on the rear of the power supply. The electrical interface outputs may be configured for open collector mode or for signal mode (signal voltage levels as indicated), by setting the user I/O DIP switch.

DIP switch SW1 for the user I/O is located next to the J3 on the back of the 2000-series power supply. User I/O interface cable pinout is listed in [Table 4.6 User I/O Input and Output Function Selection](#).

**Figure 4.12** User I/O Cable Identification and Wire Color Diagram





**Table 4.5** User I/O Cable Pin Assignments, Alphabetical Order

Pin	Signal Name	Signal Type	Direction	Signal Range	Definition	Colors
7	ACT_CLEAR	0V True	Output	0/24V, 100mA	Actuator clear signal	Red/Wht
24	AMPLITUDE_OUT	Analog	Output	0V to 10V	Amplitude signal from PS	Red/Blk/Grn
2	CYCLE_ABORT	24V True	Input	0/24V, 100mA		Red/Blk
3	EXT_RESET	24V True	Input	0/24V, 100mA	System Reset	Grn/Blk
18	EXT_SEEK+	24V True	Input	0/24V, 100mA		Red/Blk/Wht
38	FREQ_OUT	Analog	Output	-10V to +10V	Frequency Signal from PS	Blk/Wht/Blu
6	G_ALARM	0V True	Output	0/24V, 100mA		Blk/Wht
14	GEN_ALARM_RELAY_1	Relay Contact	Output	40V, 0.25A	Contact Closure	Red/Grn
29	GEN_ALARM_RELAY_2	Relay Contact	Output	40V, 0.25A	Contact Closure	Wht/Red/Orn
1	J3_1_INPUT	24V True	Input	0/24V, 100mA	User definable inputs. Refer to <a href="#">Table 4.6 User I/O Input and Output Function Selection</a> to view available selections.	Wht/Blk
17	J3_17_INPUT	24V True	Input	0/24V, 100mA		Wht/Blk/Red
19	J3_19_INPUT	24V True	Input	0/24V, 100mA		Grn/Blk/Wht
31	J3_31_INPUT	24V True	Input	0/24V, 100mA		Wht/Red/Blu
32	J3_32_INPUT	24V True	Input	0/24V, 100mA		Blk/Wht/Grn
33	J3_33_INPUT	24V True	Input	0/24V, 100mA		Wht/Blk/Grn
8	J3_8_OUTPUT	24V True	Output	0/24V, 100mA		User definable outputs. Refer to <a href="#">Table 4.6 User I/O Input and Output Function Selection</a> to view available selections.
22	J3_22_OUTPUT	24V True	Output	0/24V, 100mA	Blk/Red/Grn	
36	J3_36_OUTPUT	24V True	Output	0/24V, 100mA	Orn/Red/Grn	
9	MEM	Analog	Output	-10V to +10V	Memory Signal from PS	Blu/Wht
11	MEM_CLEAR	Open Collector	Output	24V, 25mA max	Memory Clear signal send to PS	Wht/Red
40	MEMORY_STORE	Open Collector	Output	24V, 25mA max	Memory store from PS	Red/Wht/Blu
34	PB_RELEASE	0V True	Output	0/24V, 100mA		Red/Wht/Grn

**Table 4.5** User I/O Cable Pin Assignments, Alphabetical Order

Pin	Signal Name	Signal Type	Direction	Signal Range	Definition	Colors
37	PWR	Analog	Output	0V to 10V	Power Signal from PS	Blu/Red/ Grn
21	READY	0V True	Output	0/24V, 100mA		Blu/Blk/ Wht
5	REJECT	0V True	Output	0/24V, 100mA		Blu/Blk
43	READY_RELAY_1	Relay Contact	Output	40V, 0.25A	Contact Closure	Blu/Orn/ Red
15	READY_RELAY_2	Relay Contact	Output	40V, 0.25A	Contact Closure	Orn/Grn
26	RUN	Open Collector	Output	24V, 25mA max	Run signal send to PS	Orn/Blk/ Grn
39	SEEK	Open Collector	Output	24V, 25mA max	Seek Signal send to PS	Wht/Blk/ Blu
4	SOL_VALVE_SRC	24V	Output	0/24V, 125mA	SV1 Source	Orn/Blk
16	SOL_VALVE_RTN	24V Return	Input	0V	SV1 Return	Blk/Wht/ Red
20	SUSPECT_PART	0V True	Output	0/24V, 100mA		Orn/Blk/ Wht
10	USER_AMP_IN	Analog	Input	-10V to +10V	User Amplitude control signal	Blk/Red
25	USER_FREQ_OFFSET	Analog	Input	-10V to +10V	User Freq. offset control signal	Grn/Blk/ Orn
35	WELD_ON	0V True	Output	0/24V, 100mA	Start of sonics and trigger	Grn/Wht/ Blu
30	WELD_ON_RELAY_1	Relay Contact	Output	40V, 0.25A	Contact Closure	Orn/Wht/ Blu
44	WELD_ON_RELAY_2	Relay Contact	Output	40V, 0.25A	Contact Closure	Blk/Orn/ Red
23	+10V_REF	Analog	Output	10.0V	10VDC ref. voltage from PS	Wht/Red/ Grn
12	24V_RTN	24V Ground	Input	0V	24V Return	Orn/Red
13	24V_SRC	24V Source	Output	24V, 1.25A max	24V Source	Blu/Red
27	24V_RTN	24V Ground	Input	0V	24V Return	Blu/Wht/ Orn
28	24V_SRC	24V Source	Output	24V, 1.25A max	24V Source	Blk/Wht/ Orn
41	24V_RTN	24V Ground	Input	0V	24V Return	Grn/Orn/ Red
42	24V_SRC	24V Source	Output	24V, 1.25A max	24V Source	Orn/Red/ Blu

CAUTION	
	<p>Ensure all unused wires are properly isolated. Failure to do so may result in Power Supply or system failure.</p>

NOTICE	
	<p>Refer to the Branson Automation Guide (EDP 100-214-273) for additional information about selection and use of Input and Output features listed in the following Table.</p>


**Table 4.6** User I/O Input and Output Function Selection

Input		Output	
J3_1_INPUT	Disabled	J3_8_OUTPUT	Disabled Confirm Preset Ext Beeper Cycle Okay No Cycle Alarm Overload Alarm Modified Alarm Note External Start Sync Out
J3_17_INPUT	Select Preset*	J3_22_OUTPUT	
J3_19_INPUT	Ext U/S Delay	J3_36_OUTPUT	
J3_31_INPUT	Display Lock		
J3_32_INPUT	Sonics Disable		
J3_33_INPUT	Memory Reset		
	External Start		
	Ext Signal		
	Sync In		

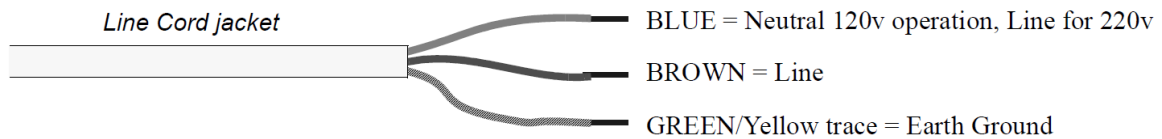
\* This option is not available at J3-1 Input.

## 4.6.3 Input Power Plug

If you must add or change the input power plug, use the following color code for the conductors found in the international harmonized line cord. Add the plug that is appropriate for your input power receptacle.

CAUTION	
	<p>The power supply can be permanently damaged if it is connected to the incorrect line voltage, or if the wiring connection is mis-wired. It also presents a safety hazard if mis-wired. Use of the correct plug or connector helps prevent incorrect connections.</p>

**Figure 4.13** International Harmonized Line Cord Color Code



## 4.6.4 User I/O DIP Switch (SW1)

DIP switch SW1, for the user I/O is located next to the J3 on the back of the 2000-series power supply, as shown in [Figure 4.9 Connections on Rear of Power Supply](#). The settings of these switches affect the user I/O signals. Factory default setting is for all dip switches is set to ON (closed: switch position closest to number designation).



- If the dip switch is set to the ON (closed) position, the corresponding Output pin will be configured as the current source, 25mA max
- If the dip switch is set to the OFF (open) position, the corresponding Output pin will be configured as an "open collector", 24VDC, 25 mA max. current sink

**Table 4.7** User I/O DIP Switch Functions

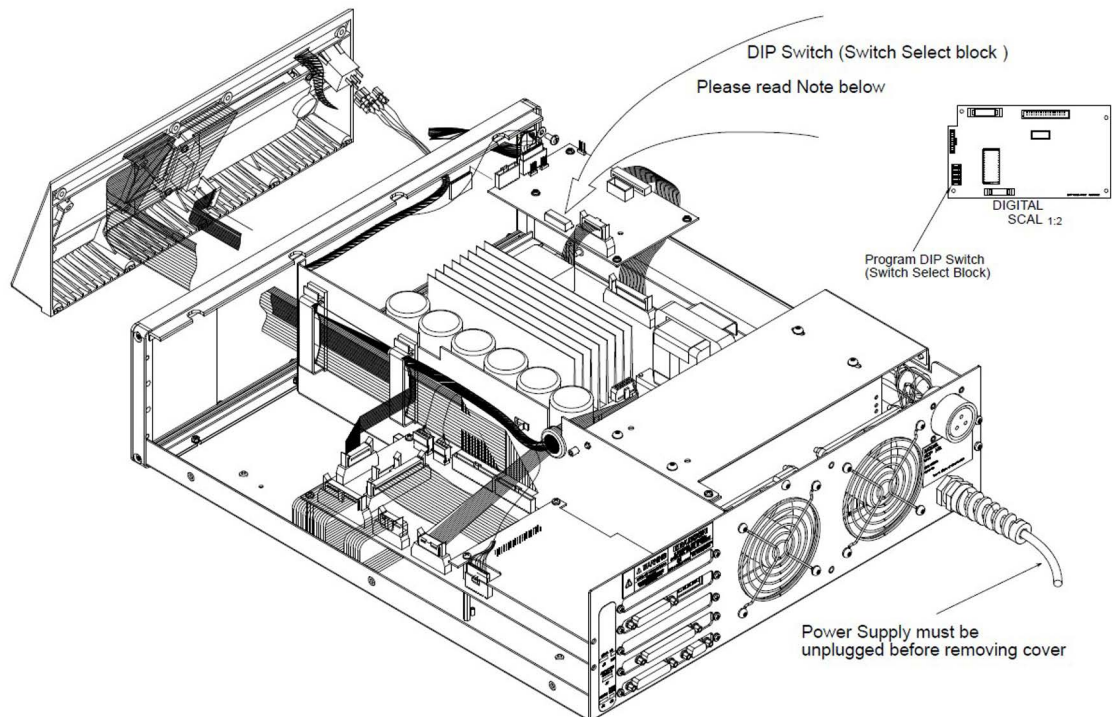
Switch Position	Signal Description	Output Signal
1	REJECT_SIG	REJECT
2	SUSPECT_SIG	SUSPECT
3	PB_RELEASE_SIG	PB_RELEASE
4	G_ALARM_SIG	G_ALARM
5	READY_SIG	READY
6	WELD_ON_SIG	WELD_ON
7	ACTUATOR_CLEAR_SIG	ACT_CLEAR
8	J3_22_OUT_SIG	J3_22_OUTPUT
9	J3_36_OUT_SIG	J3_36_OUTPUT
10	J3_8_OUT_SIG	J3_8_OUTPUT


## 4.6.5 Power Supply Module Options DIP Switch

When using the Digital UPS in automated configurations, it might be necessary to open the Power Supply and change the DIP (Dual In-line Package) switches on the power module. DIP switches change the Seek and Start functions and can affect the Amplitude Control functions. Operations using the Digital UPS are software controlled.

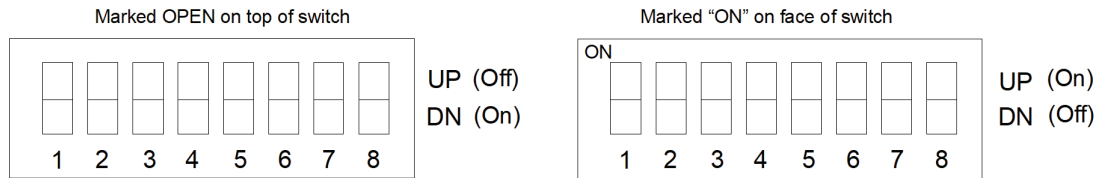
CAUTION	
	<p>The components in the Power Supply are subject to damage from electro-static discharge. When working inside the Power Supply, use a grounded wrist strap and minimize your movement to reduce the possibility of damage due to static electricity.</p>
WARNING	
	<p>Unplug the Power Supply (if previously connected) and wait at least two (2) minutes before opening the Power Supply case. Hazardous Voltages exist and are stored in the system.</p>


**Figure 4.14** DIP Switch Location on the Analog and Digital Power Supply Module



NOTICE	
	<p>There are two variations of the DIP switch and each is used interchangeably. The switch will have either "Open" or "On" printed on it to indicate position function. Carefully note the orientation of the On/Off positions as illustrated, since one orientation is exactly the opposite of the other.</p>

**Figure 4.15** Switch Select Block



NOTICE	
	<p>This switch controls circuits which are based on negative logic. This means that turning a switch position to Off will actually be turning a circuit on, and turning a switch position to On will be turning a circuit off.</p>

**To change Power Supply Module DIP switch settings, take the following steps\*:**

**Table 4.8** Changing Power Supply Module DIP switch settings

Step	Action
1	Turn off and unplug the Power Supply.
2	Allow at least 5 minutes for capacitors to discharge.
3	Open the Power Supply by removing the seven screws on the cover (three on each side, and one in the rear). Remove the cover and set it aside.
4	Locate the DIP switches and default settings as shown in <a href="#">Figure 4.14 DIP Switch Location on the Analog and Digital Power Supply Module</a> .
5	Change the DIP switch settings to suit your application requirements (refer to <a href="#">Table 4.9 DIP Switch Settings*</a> ).

\*It is not necessary to remove the Control Board to change the DIP settings.

**Table 4.9** DIP Switch Settings\*

Function	Options	Default Settings	Sw Pos
Seek	Seek on power-up - Checks horn frequency upon power up and stores the value in memory	Off	1
	Auto-Seek - checks horn frequency once each minute, from the time of the last activation of ultrasonics	On (This default setting renders Auto-Seek inoperative)	2
	Auto-Seek duration - indicates the length of time the Auto-Seek function is active	On = short Off = standard	3
	Store at end of weld - updates horn frequency memory at the end of each weld	Off	4
<b>NOT USED</b>			5
Amplitude Control	<b>NOTICE</b> DIP 6 must be in the Off position.	Off	6
Start	Short - sets ramp time to 10 ms.	7-On 8-On	7 - 8
	Medium - sets ramp time to 35 ms.	7-Off 8-On	7 - 8
	Standard - sets ramp time to 80 ms*.	7-On 8-Off	7 - 8
	Long - sets ramp time to 105 ms.	7-Off 8-Off	7 - 8

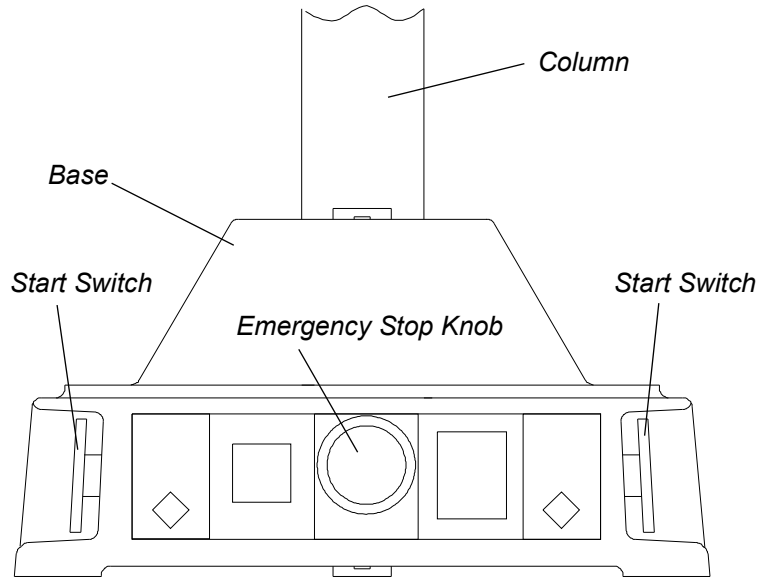
\*Refer to [Figure 4.15](#)

## 4.7 Guards and Safety Equipment


### 4.7.1 Emergency Stop Control

If you use the Emergency Stop button on the Actuator to terminate a weld, twist the button to reset it. (The welder will not operate until this button is reset.) You must then press Reset at the power supply. If you are running automation, you can use external reset that is connected to your User I/O board.

**Figure 4.16** Actuator Emergency Stop Button



If you are using an Emergency Stop signal from the Start Switch cable, you must clear the Emergency Stop condition before the System will operate.

WARNING	
	The Emergency Stop should be engaged prior to removing the door.



The 2000 Series control system has been designed to conform to the safety requirements of NFPA 79, EN 60204-1 and CFR 1910.212.

Two Hand Control of the 2000 Series control system has been designed to comply with Type 3 of NFPA, and Type III of EN 60204-1.

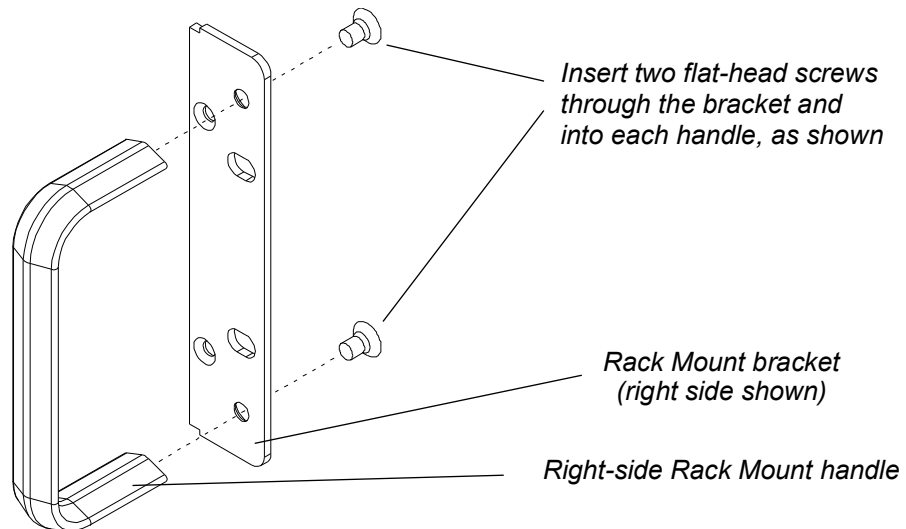
The Emergency Stop functions as a category 0 stop of both NFPA 79 and EN 60204-1.

## 4.8 Rack Mount Installation

If the system is Rack Mounted, you need to order the Rack Mount handle kit. The kit includes two rack mounting handles and two corner pieces, which support the handles and provide the rack mount interface.

CAUTION	
	<p>The Rack Mount handle kit does NOT support the power supply in the rack. The weight of the power supply must be supported by integral brackets of the rack itself.</p>
NOTICE	
	<p>Do not permanently remove the Cover from the Power Supply because it is required for proper system cooling.</p>

**Figure 4.17** Detail of Rack Mount Handle Kit Assembly




**Table 4.10** Rack Mount Handle Kit Assembly


Step	Action
1	Order and obtain the Rack Mount kit for your Power Supply. The brackets in the Kit are designed for standard 19-inch rack mounting options.
2	From the front corners of the Power Supply, remove the corner trim pieces by removing the two Phillips screws. Save the screws.

**Table 4.10** Rack Mount Handle Kit Assembly

Step	Action
3	Noting that one side of each bracket is countersunk to accept the provided flathead screws, assemble the Rack Mount Handles as shown in <a href="#">Figure 4.17 Detail of Rack Mount Handle Kit Assembly</a> . (This shows only the Right bracket and handle; the left side is a mirror-image.) Tighten the screws securely and so they are flush.
4	Re-using the screws you removed in Step 2, install the assembled Handle in place of the Front Corner pieces.
5	Save the removed hardware corner pieces.
6	When you are ready to install the unit, use the hardware from your Rack Mounting system to locate the Power Supply.

## 4.9 Assemble the Acoustic Stack

CAUTION	
	<p>The following procedure must be performed by a setup person. If necessary, secure the largest portion of a square or rectangular horn in a soft jawed vise. NEVER attempt to assemble or remove a horn by holding the converter housing or the booster clamp ring in a vise.</p>

CAUTION	
	<p>Do not use silicone grease with Mylar washers. Use only 1 (one) Mylar washer of the correct inside and outside diameters at each interface.</p>

**Table 4.11** Tools

Tool	EDP Number
15, 20, and 30 kHz Torque Wrench Kit	101-063-787
40 kHz Torque Wrench	101-063-618
20 kHz Spanner Wrench	101-118-039
30 kHz Spanner Wrench	201-118-033
40 kHz Spanner Wrench	201-118-024
Silicone Grease	101-053-002

### 4.9.1 For a 20 kHz System

**Table 4.12** Assembling the Acoustic Stack in a 20 kHz System

Step	Action
1	Clean the mating surfaces of the converter, booster, and horn. Remove any foreign material from the threaded holes.

**Table 4.12** Assembling the Acoustic Stack in a 20 kHz System

Step	Action
2	Install the threaded stud into the top of the booster. Torque to 450 in-lbs, 50.84 Nm. If the stud is dry, apply 1 or 2 drops of a light lubricating oil before installing.
3	Install the threaded stud into the top of the horn. Torque to 450 in-lbs, 50.84 Nm. If the stud is dry, apply 1 or 2 drops of a light lubricating oil before installing.
4	Install a single Mylar washer (matching the size of the washer to the stud) to each interface.
5	Assemble the converter to the booster and the booster to the horn.
6	Torque to 220 in-lbs, 24.85 Nm. (Torque 20 kHz Solid Mount Converter to 250 in-lbs, 28.25 Nm).

## 4.9.2 For a 30 kHz System

**Table 4.13** Assembling the Acoustic Stack in a 30 kHz System

Step	Action
1	Clean the mating surfaces of the converter, booster, and horn. Remove any foreign material from the threaded holes.
2	Apply a drop of Loctite® 290 (or equivalent) to the studs for the booster and horn.
3	Install the threaded stud into the top of the booster; torque to 290 in-lbs, 32.76 Nm, and let cure for 30 minutes.
4	Install the threaded stud into the top of the horn; torque to 290 in-lbs, 32.76 Nm, and let cure for 30 minutes.
5	Install a single Mylar washer (matching the size of the washer to the stud) to each interface.
6	Screw the converter onto the booster.
7	Torque to 185 in-lbs, 21 Nm.
8	Slide the booster/converter assembly into the adapter sleeve. Screw on the adapter sleeve ring nut and leave loose.
9	Screw the booster onto the horn.
10	Repeat Step 7.
11	Securely tighten the adapter sleeve ring nut with the spanner wrenches shipped with the sleeve assembly.

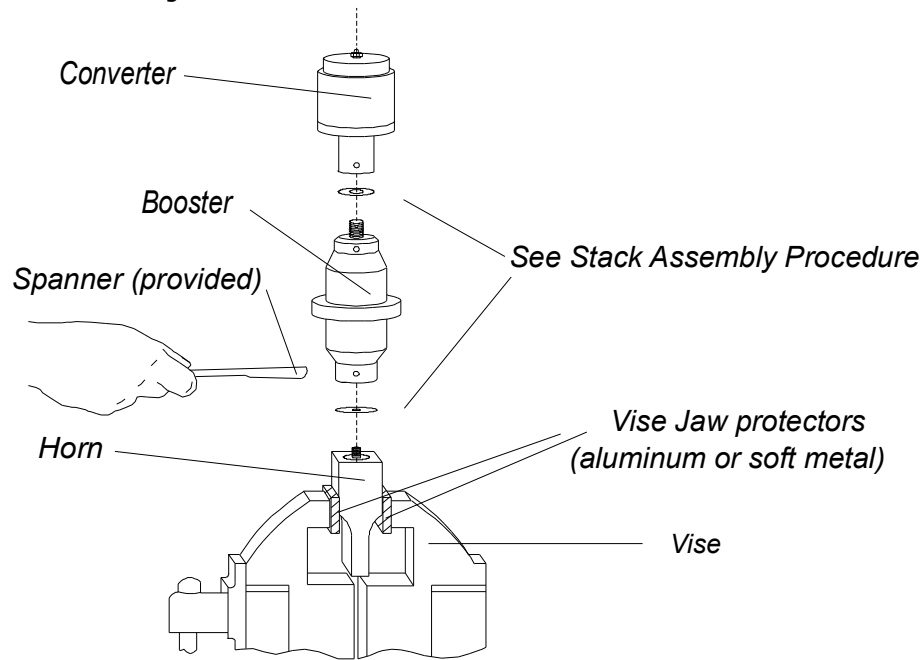
### 4.9.3 For a 40 kHz System

**Table 4.14** Assembling the Acoustic Stack in a 40 kHz System


Step	Action
1	Clean the mating surfaces of the converter, booster, and horn. Remove any foreign material from the threaded holes.
2	Apply a drop of Loctite® 290 (or equivalent) to the studs for the booster and horn.
3	Install the threaded stud into the top of the booster; torque to 70 in-lbs, 7.91 Nm, and let cure for 30 minutes.
4	Install the threaded stud into the top of the horn; torque to 70 in-lbs, 7.91 Nm, and let cure for 30 minutes.
5	Coat each interface surface with a thin film of silicon grease – <i>but do not apply silicon grease to a threaded stud or tip.</i>
6	Screw the converter to the booster.
7	Torque to 95 in-lbs, 10.73 Nm.
8	Slide the booster/converter assembly into the adapter sleeve. Screw on the adapter sleeve ring nut and leave loose.
9	Screw the booster onto the horn.
10	Repeat Step 7.
11	Securely tighten the adapter sleeve ring nut with the spanner wrenches shipped with the sleeve assembly.

## 4.9.4 Assembling the Acoustic Stack (shown with rectangular horn secured in the vise)

**Figure 4.18** Assembling the 20 kHz Acoustic Stack



### Stack Assembly Torque Tables

NOTICE	
	<p>The use of a Branson torque wrench or the equivalent is recommended. P/N 101-063-787 for 15, 20, and 30 kHz systems, and 101-063-618 for 40 kHz systems.</p>

**Table 4.15** Stud Torque Values

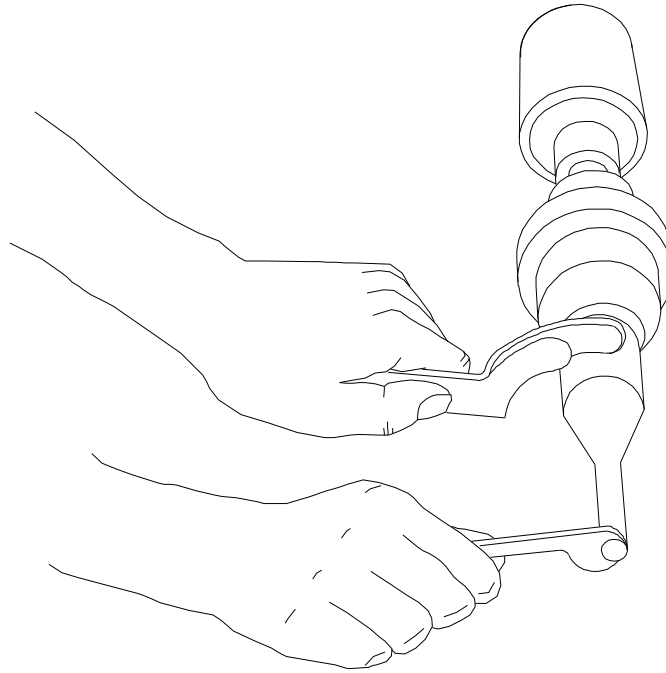
Used On	Stud Size	Torque	EDP #
20 kHz	1/2" x 20 x 1-1/4"	450 in.-lbs, 50.84 Nm.	100-098-370
20 kHz	1/2" x 20 x 1-1/2"	450 in.-lbs, 50.84 Nm.	100-098-123
30 kHz *	3/8" x 24 x 1"	290 in.-lbs, 32.76 Nm.	100-298-170R
40 kHz *	M8 x 1.25	70 in.-lbs, 7.91 Nm.	100-098-790

\* Add a drop of Loctite 290 to the stud. Torque and let cure for 30 minutes before use.

### 4.9.5 Connecting Tip to Horn

1. Clean the mating surfaces of the horn and tip. Remove foreign matter from the threaded stud and hole.
2. Hand assemble the tip to the horn. Assemble dry. Do not use any silicone grease.
3. Use the spanner wrench and an open-end wrench (Refer to [Figure 4.19](#)) and tighten to the following torque tip specifications:

**Figure 4.19** Connecting Tip to Horn



**Table 4.16** Tip to Horn Torque Values

Tip Thread	Torque
1/4 - 28	110 in.-lbs, 12.42 Nm.
3/8 - 24	180 in.-lbs, 20.33 Nm.

## 4.10 Installing the Ultrasonic Stack in the Actuator

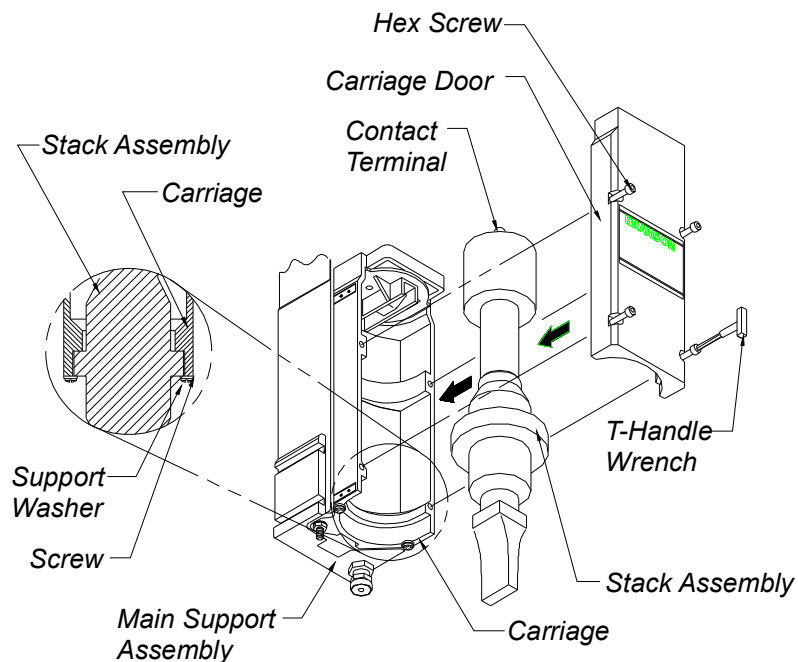
This section lists the steps and indicates the assembly procedures for various ultrasonic stacks.

### 4.10.1 15 kHz, 20 kHz, and 30 kHz CA Converter Stacks

The ultrasonic stack must first be assembled. To install the stack:

1. Make sure that the system power is turned off by disconnecting the power plug.
2. Engage the Emergency Stop.
3. Loosen the four door screws.
4. Pull the door straight off and set it aside.
5. Take the assembled ultrasonic stack and align the ring on the booster just above the support washer in the carriage. Firmly push the stack into place, with the acorn nut on the top of the converter making contact with the contactor in the top of the carriage.
6. Reinstall the door assembly, and start the four door screws.
7. Align the horn by rotating it, if necessary. Torque the carriage door to 20 in.-lbs to secure the stack.

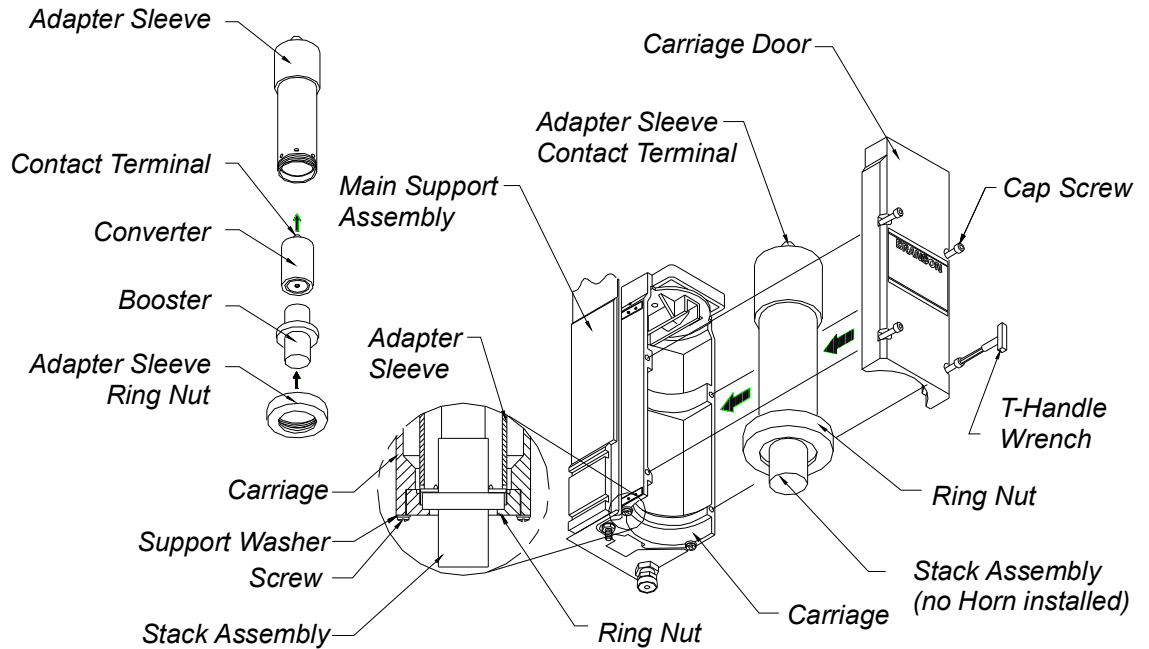
**Figure 4.20** Installing a 20 kHz Stack in a Branson Actuator




### 4.10.2 40 kHz Stacks

1. Make sure the system power is turned off by disconnecting the power plug.
2. Place the converter/booster in the sleeve.
3. Loosen four carriage door screws.
4. Pull the door straight off and set it aside.
5. Take the assembled sleeve and align the ring nut on the booster just above the support washer in the carriage. Firmly push the sleeve into place, with the acorn nut on the top of the sleeve making contact with the contactor in the top of the carriage.

**Figure 4.21** Installing the 40 kHz Stack in a Branson Actuator




6. Reinstall the door assembly, and start the four door screws.
7. Align the horn by rotating it, if necessary. Torque the carriage door to 20 in-lbs to secure the stack.

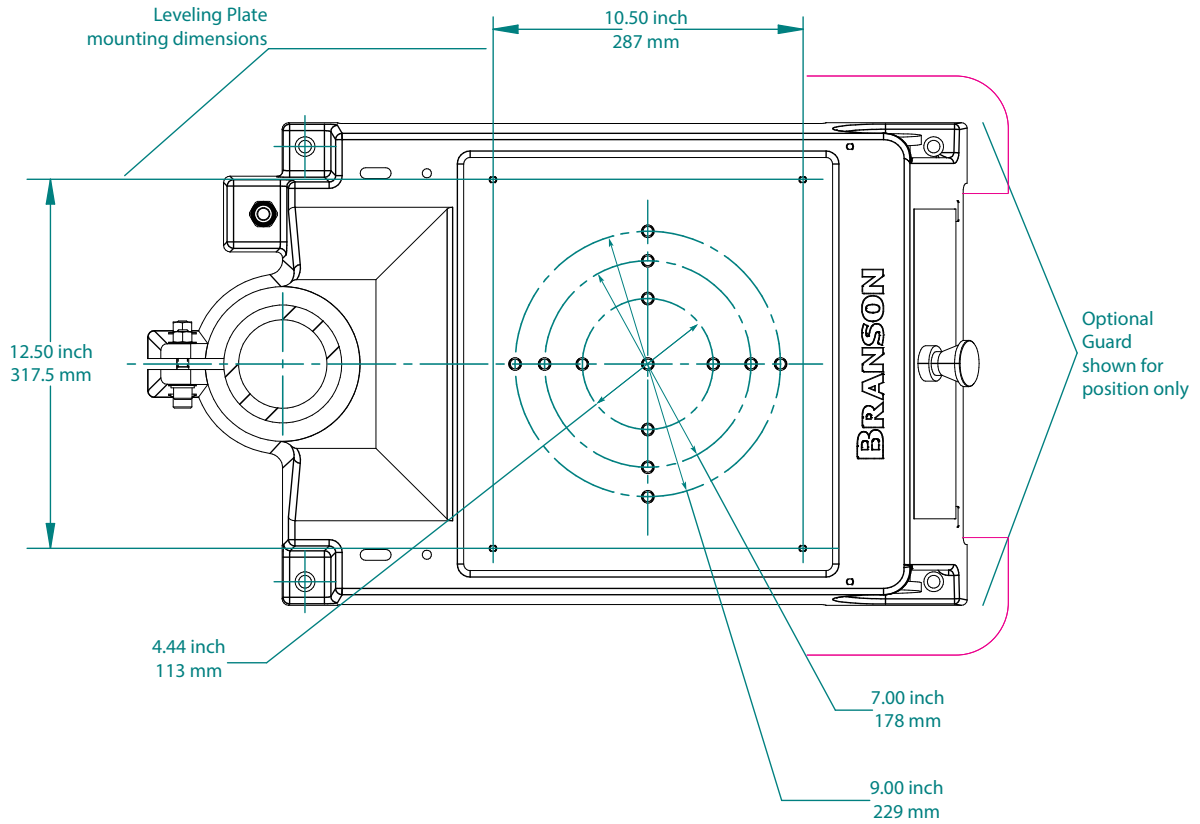
CAUTION	
	<p>Do not attempt to hold the sleeve in a vise. It can be easily crushed or damaged.</p>

### 4.10.3 Mounting the Fixture on the Branson Base (hardware and mounting holes)

The base provides mounting holes for your fixture. Mounting holes are also provided for the optional Branson leveling plate kit. The base is tapped for metric M10-1.5 hardware. The mounting holes are arranged in three concentric bolt circles with the following dimensions.

CAUTION	
	<p>The base is cast metal and the mounting holes can become stripped if the hardware is overtightened. Tighten your hardware only enough to prevent movement of your fixture.</p>

**Figure 4.22** Mounting Circles on Base



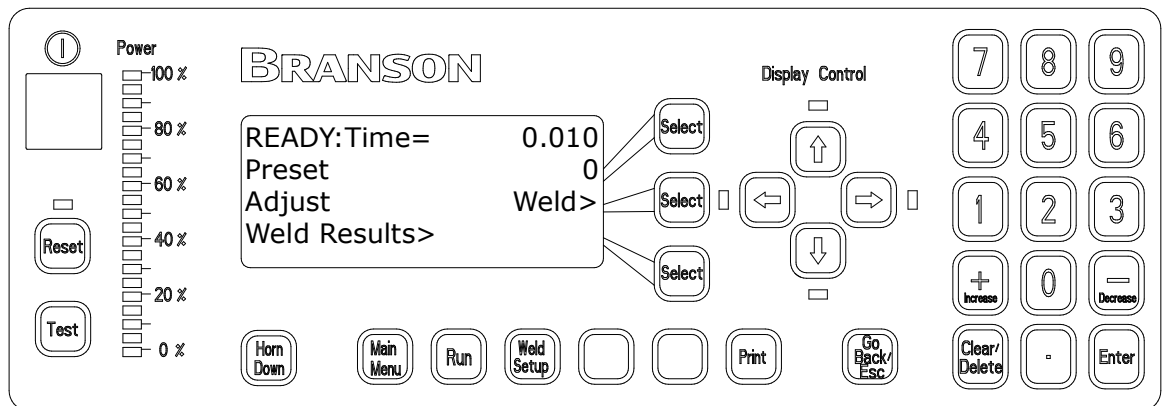
The optional guard (sometimes required with very large horns) is shown for position only. It extends several inches to either side of the base, and prevents the user from operating the welder and pinching their fingers or hands between the base and the tooling.

## 4.11 Testing the Installation

1. Turn on the air supply connections with the air pressure regulator set at minimum values, and verify that the system has air pressure.
2. Ensure there are no leaks in the air supply connections.
3. Turn on the power supply. The power supply will begin its normal self-check.
4. If the power supply displays an alarm message, find the alarm message definition, cause and correction in [Chapter 7: Maintenance](#) of this manual.
5. Press the **Test** button.
6. If the power supply displays an alarm message at this point, find the alarm message definition in the Maintenance section of [Chapter 7: Maintenance](#) of the power supply manual. If there are no alarm messages displayed, go on to the next step.
7. Fit a test part onto the fixture.
8. Press the **Horn Down** key and then press and hold the two start switches. The horn will descend to the fixture on the base of the Actuator. This verifies specifically that the pneumatic system is working.
9. Press the **Horn Down** key again. The horn will retract. The system should now be functional and can be set up for your application.

In summary, if the power supply does not display an alarm message and the descends and retracts correctly, your ultrasonic welder is ready for operation.

**Figure 4.23** Normal Front Panel Display after Power -Up



## 4.12 Still Need Help? or Parts? Have Questions?

Branson is pleased that you chose our product and we are here for you! If you need assistance with your 2000-series system, call your local Branson representative or contact Branson customer service by calling the appropriate department as indicated in [Table 1.2 Branson Contacts](#), on Section [1.5.3 Departments to Contact](#).

---

## **Chapter 5: Technical Specifications**

---

<b>5.1</b>	<b>Technical Specifications</b> .....	<b>78</b>
<b>5.2</b>	<b>Physical Description</b> .....	<b>80</b>
<b>5.3</b>	<b>Standard Modules and Components</b> .....	<b>81</b>

## 5.1 Technical Specifications

### 5.1.1 Environmental Requirements

The 2000X Power Supply has the following environmental requirements.

**Table 5.1** Environmental Requirements

Environmental Concern	Acceptable Range
Ambient Temperature	+41°F to +122°F (+5°C to +50°C)
Storage/Shipping Temperature	-13°F to +158°F (-25°C to +70°C)
Humidity	Maximum 95% non-condensing
Operating Altitude	Up to 6560 ft (2000 m)

### 5.1.2 Electrical Requirements

The following tables list input voltage and current requirements for the 2000X Welding System, and includes power required when it is used with Branson 2000X-series Actuators.

**Table 5.2** Electrical Input Operating Voltages

Power Supply Rating	Nominal Input Operating Voltage, +/-10%
40 kHz / 400 W	100 - 120, 200 - 240 V, 50/60 Hz, Single Phase
40 kHz / 800 W	100 - 120, 200 - 240 V, 50/60 Hz, Single Phase
30 kHz / 750 W	100 - 120, 200 - 240 V, 50/60 Hz, Single Phase
30 kHz / 1500 W	200 - 240 V, 50/60 Hz, Single Phase
20 kHz / 1125 W	100 - 120, 200 - 240 V, 50/60 Hz, Single Phase
20 kHz / 2500 W	200 - 240 V, 50/60 Hz, Single Phase
20 kHz / 4000 W*	220 - 253 V, 50/60 Hz Single Phase

\* This unit is rated at a 25% duty cycle with 5 second On time, 2000W continuous. Rated power is 4000W at 40°C.

**Table 5.3** Input Current and Fuse Requirements

Model	Power	Current Rating
20 kHz	1250 W 200V - 240V	7 Amp Max. @ 200V / 20 Amp fuse
	1250 W 100V - 120V	14 Amp Max. @ 100V / 20 Amp fuse
	2500 W 200V - 240V	14 Amp Max. @ 200V / 20 Amp fuse
	4000 W 220V - 240V	25 Amp Max. @ 220V / 25 Amp fuse

**Table 5.3** Input Current and Fuse Requirements

Model	Power	Current Rating
30 kHz	750 W 100 - 120V	10 Amp Max. @ 100V / 20 Amp fuse
	750 W 200 - 240V	5 Amp Max. @ 200V / 20 Amp fuse
	1500 W 200V - 240V	10 Amp Max. @ 200V / 20 Amp fuse
40 kHz	400 W 200V - 240V	3 Amp Max. @ 200V / 20 Amp fuse
	400 W 100V - 120V	5 Amp Max. @ 100V / 20 Amp fuse
	800 W 200V - 240V	5 Amp Max. @ 200V / 20 Amp fuse
	800 W 100V - 120V	10 Amp Max. @ 100V / 20 Amp fuse

Cycle Rate – up to 200 cpm. Cycle rate including off time is application and stack dependent.

### 5.1.3 Pneumatic Requirements

The factory compressed air supply must be “clean (to a 5 micron level), dry and unlubricated” air with a regulated maximum pressure of 100 psig (690 kPa). Depending on your application, the actuator requires between 35 to 100 psi. Stands include an in-line air filter. Actuators (alone) require a customer-provided air filter. A quick-disconnect fitting is suggested. Use a lockout device on the air line if required.

#### Air Filter

Actuators (alone) require a customer-provided air filter which protects from particulate matter of 5 microns or larger. If a stand is mounted in a position other than upright (vertical), its air filter must be relocated and oriented so its bowl is the lowest point, and the air flow across the air filter is horizontal. This may require some re-plumbing of the existing equipment at the customer site. The air filter is held in place by two screws on a bracket bolted to the actuator support, and by the factory-installed tubing.

#### Pneumatic Tubing and Connector

Actuator assemblies are not externally plumbed from the factory, but provide conventional 1/4-inch OD pneumatic tubing connection at the air inlet. If making connections for an actuator, or if re-plumbing your system for a new air filter location, you must use 1/4-inch OD tubing and connectors rated above 100 psi (use “Imperial Eastman® Poly-Flo Tubing 44-P-1/4”, and SMC 5/16” tubing, or equivalent, and appropriate connectors).

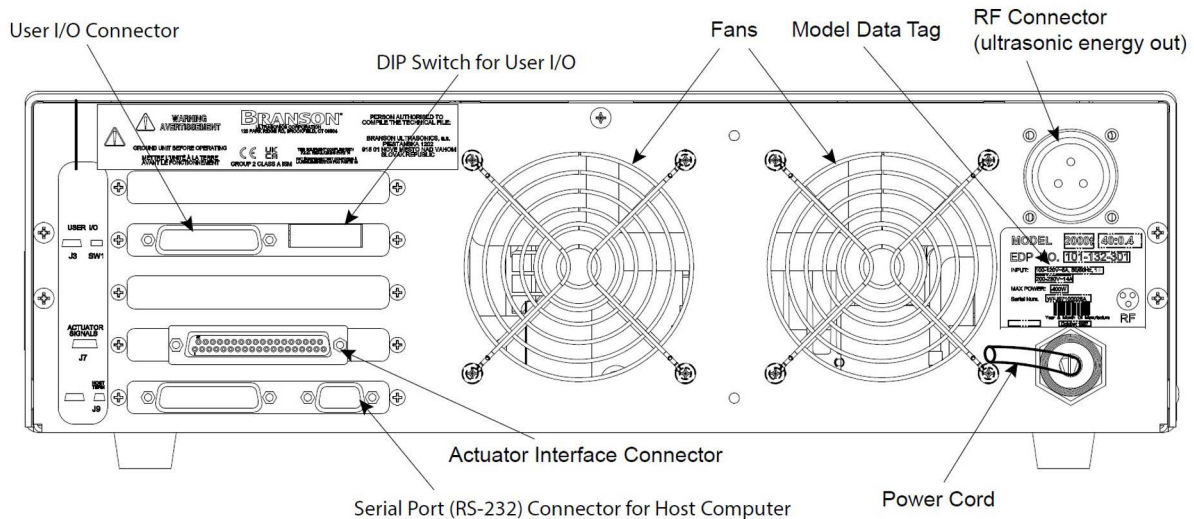
#### Pneumatic Connections to Actuator

All ae actuators require clean, dry input air at 100 psi filtered to 5 microns.

## 5.2 Physical Description

The 2000X Power Supply is part of an industrial system that can be used for ultrasonic welding, inserting, staking, spot welding, swaging, and degating thermoplastic parts, and for cutting and sealing thermoplastic fabric and film. Branson 2000X Power Supplies can operate with Actuators in manual, semi-automated, or automated systems.

**Figure 5.1** Rear View of 2000X Power Supply



The 2000X-Series Power Supply is the combination of two welding system elements in one enclosure. These elements are a power source for ultrasonic energy and a major portion of the welding system control, including the user interface. The enclosure is a standard 19" rack-mount compatible design, and can be stacked or installed up to three units high. Its design is readily convertible from its normal desktop configuration for standard 19-inch rack mount applications by adding the rack mount handles (available as a kit). The Chassis is approximately 20 inches (51 cm) in depth.

The 2000's control system is microprocessor-based, and controls the welding process while providing a level of user interface through a membrane keypad and alpha-numeric display. It employs fan-forced cooling, and is intended for horizontal placement. The front panel display and user controls are intended to be accessible from a comfortable position for an end user (operator), which means that the unit will often be installed approximately 3 to 5 feet off the floor.

## 5.3 Standard Modules and Components

The following sections describe the 2000X internal circuits.

### 5.3.1 Circuit Descriptions

The 2000X Power Supply contains the following modules:

- Line Board
- System Control Board
- Ultrasonic Power Module
- DC Power Module
- User I/O

The following sections contain descriptions for each module.

#### Line Board

The Line Board performs the dual function of providing RFI filtering for the line voltage input to the power supply, and controlling the electrical current surge to the ultrasonic Power Supply Module at power up until the inrush current limiter relay engages. The filtering also blocks ultrasonic signals from entering the AC main line. Additionally, the Line Board contains a soft start circuit module which limits the effects of current inrush.

#### System Control Board

The System Control Board controls the following functions of the Power Supply:

- Responding to start and stop signals
- Responding to alarm and reset signals
- Responding to user input from the front panel
- Activating and monitoring ultrasonics
- Provides information for Front Panel Displays
- Generate alarms
- Control communications

#### Ultrasonic Power Supply

The Ultrasonic Power Supply Module generates ultrasonic energy at the resonant frequency of your Converter-Booster-Horn Stack. The Ultrasonic Power Supply Module is configured as either analog or digital, and each contains five main circuits. The analog power supply has one preset which calls up the factory default setting. The digital power supply has a library of locked presets which are accessible for various process parameter modifications that are unique to the power supply itself. These modifications can be named to reflect specific applications, and are loaded into memory prior to shipment from the Branson factory. The parameters of the individual presets can be modified by a Branson representative. Initially all presets are set to factory default. They are accessed via an RS232 link to the system controller.

- **320VDC Power Supply:** converts AC line voltage to +320VDC for the output power devices
- **Output circuit:** matches the impedance of the output power device to the Converter-Booster-Horn Stack; and provides feedback to the Control circuit
- **Control circuits:** perform the following functions:
  - Provide drive signal to output power device
  - Determine true percentage of ultrasonic power used over a range of amplitudes
  - Allow control of the resonant frequency
  - Control starting amplitude

- **System Protection Monitor (SPM) and AutoTune with Memory (AT/M) circuit:** do the following:
  - Provide overload protection for the Ultrasonic Power Module
  - Store operating frequency of last weld (frequency memory) and use the stored frequency as a starting point for the next weld
  - Check and update frequency memory on start-up
  - Provide switch-selective starting ramp times (Start)

## DC Power Module

The Switching DC Power Module rectifies, filters, and regulates the AC voltages from the Line Transformer into DC voltages for the System Control Module. These two circuits are described below:

- **5VDC output:** provides +5VDC for the analog and digital circuitry on the System Control Module
- **24VDC output:** provides +24VDC for the System Control Module control signal and user I/O voltage

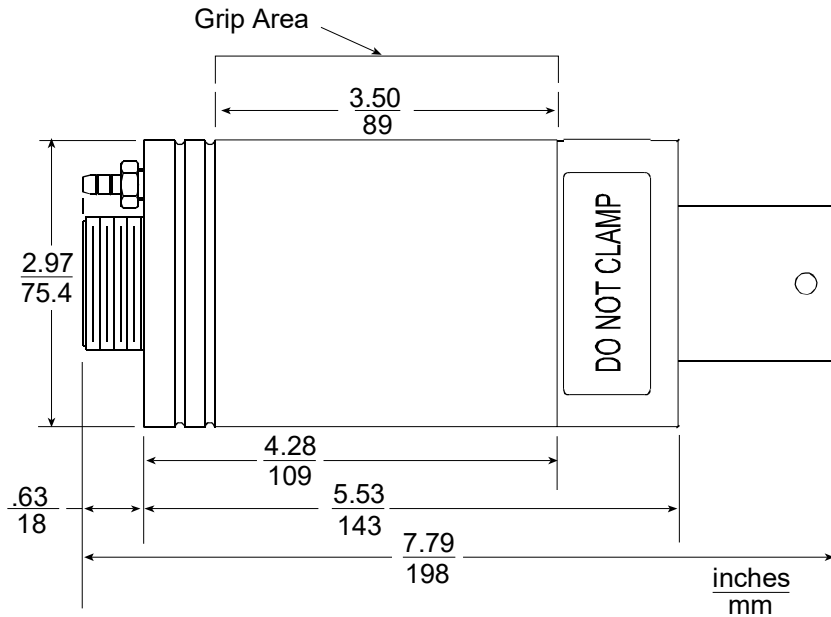
## User I/O

The User I/O board provides a standard interface for automation and is accessed on the rear of the power supply at J3. It gives the customer the ability to make their own interface for automation or special control and/or special reporting needs. Electrical interface outputs may be configured for open collector mode or for signal mode (signal voltage levels as indicated) by setting the User I/O DIP switch located next to J3.

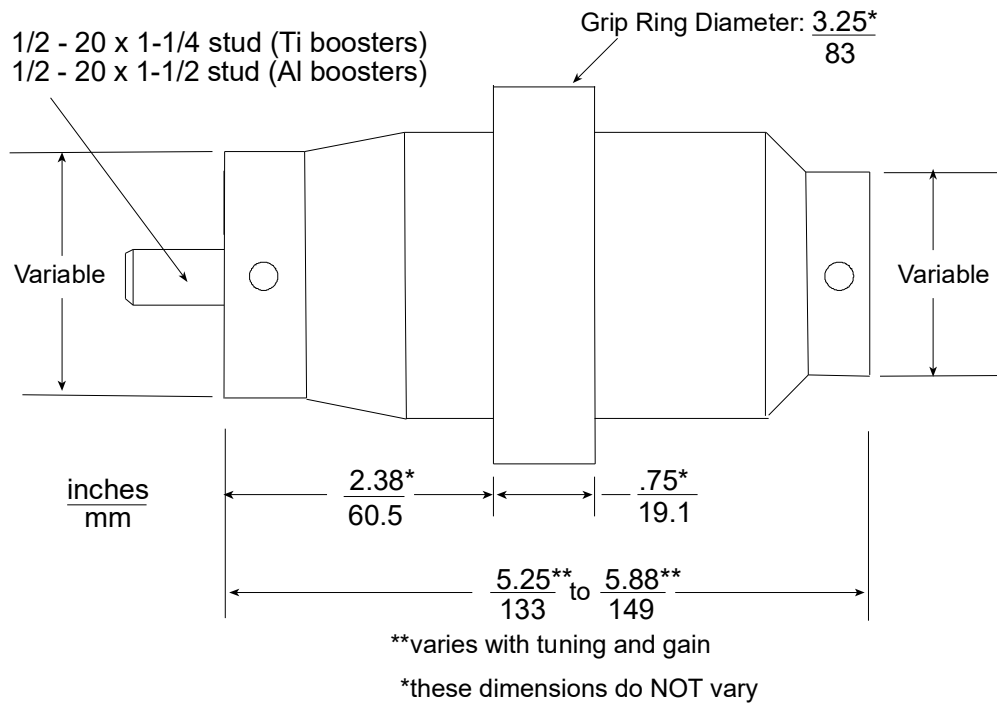
## 5.3.2 Converters and Boosters

A variety of converters and boosters available, for use with the 2000X Power Supply, are illustrated in the following pages.

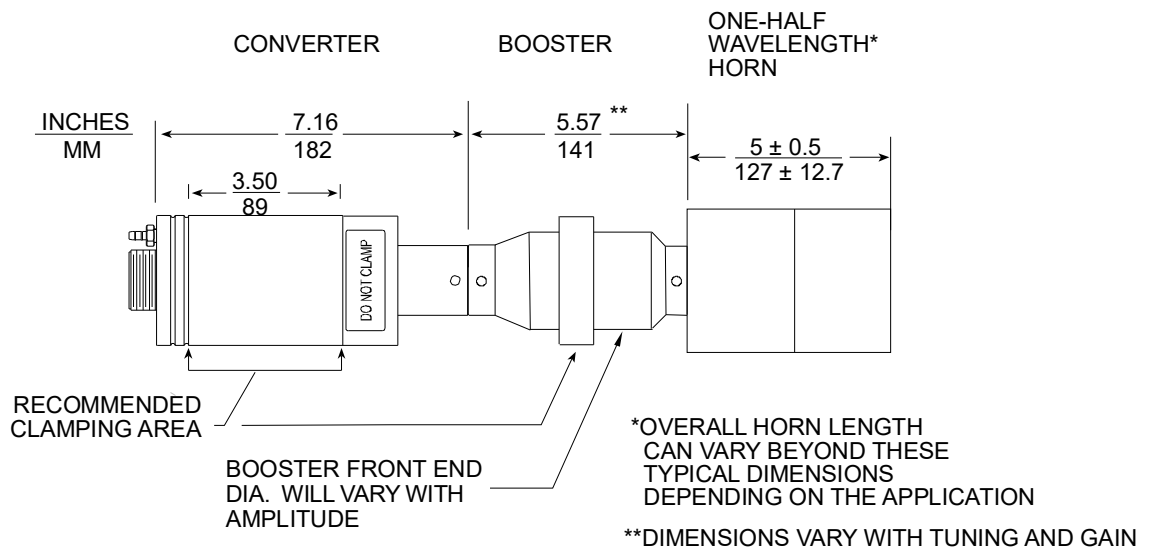
**Figure 5.2** 20 kHz CR20 Converter Dimensions



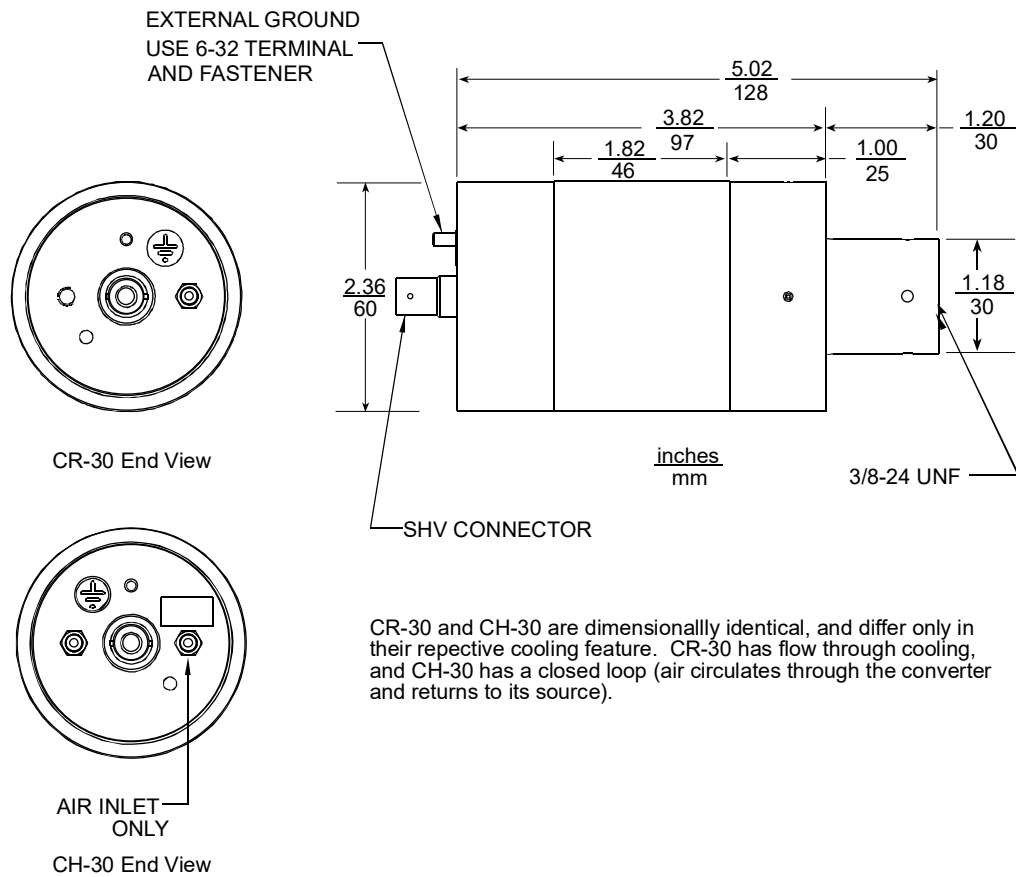
**Figure 5.3** 20 kHz Booster Dimensions



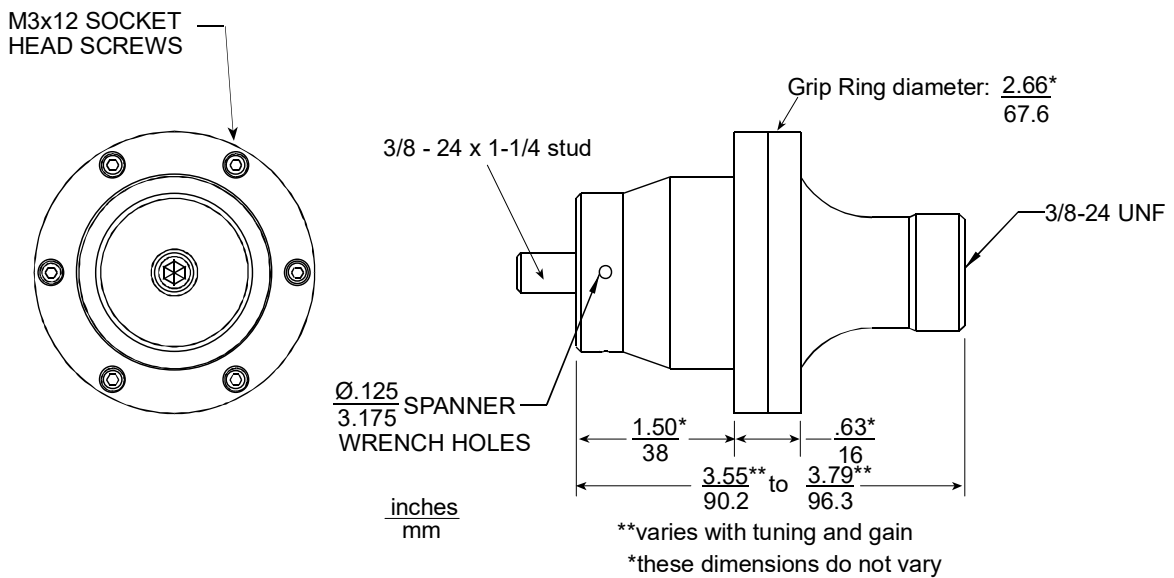
**Figure 5.4** 20 kHz Converter/Booster/Horn, Typical Dimensions



**Figure 5.5** 30 kHz Converter Dimensions

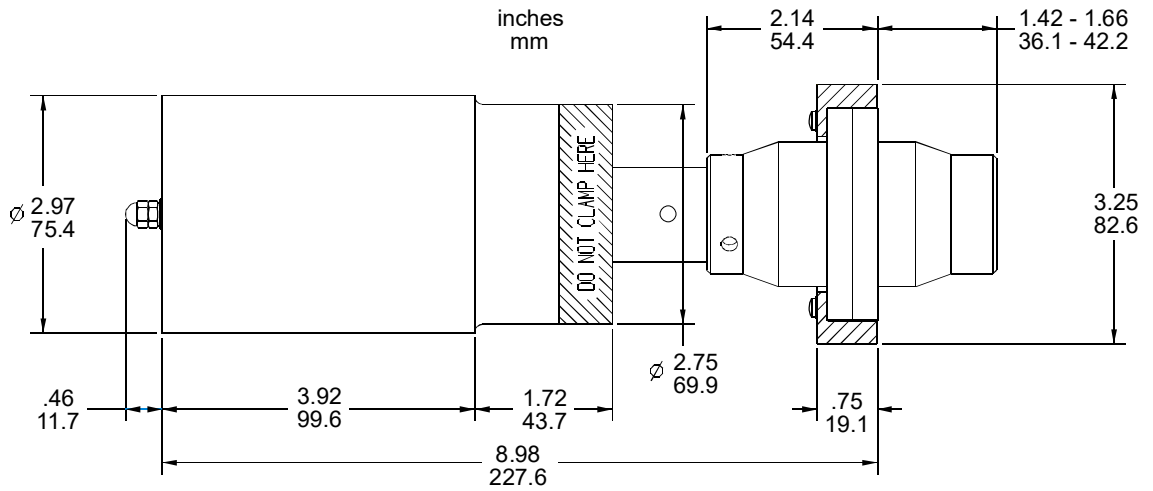


**Figure 5.6** 30 kHz Booster Dimensions

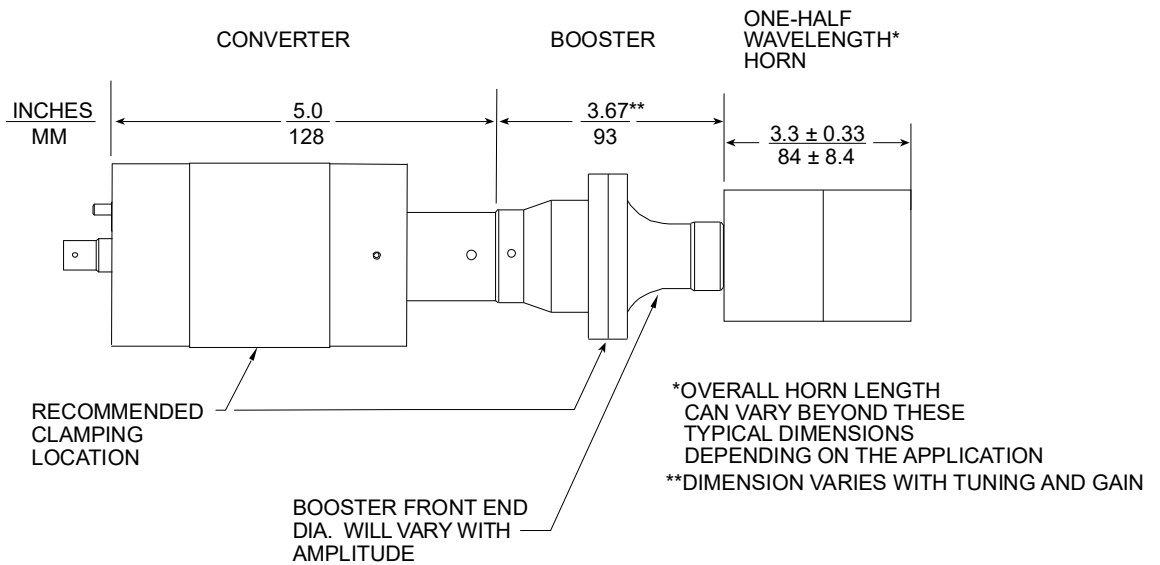


**Figure 5.7** 30 kHz, CA - 30 Converter with Booster

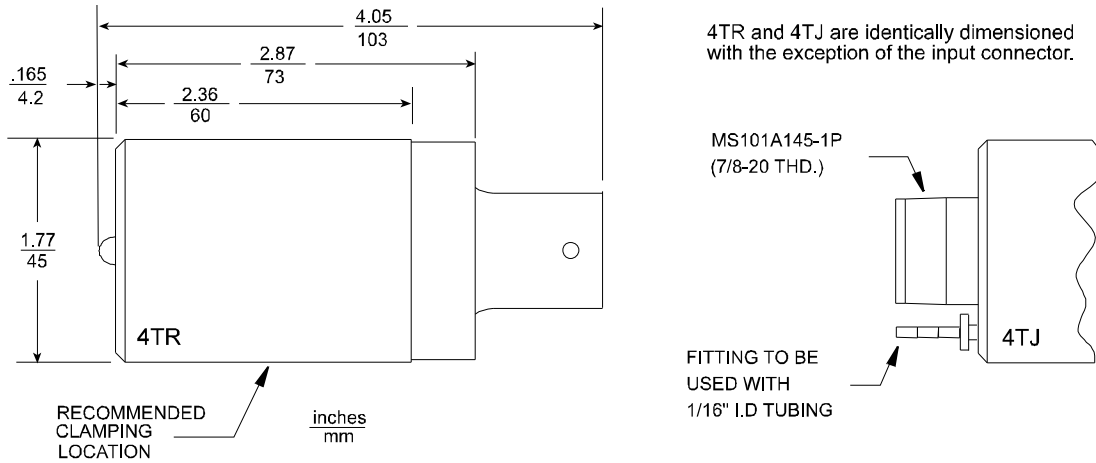
The CCA - 30 converter (EDP 159-135-114) is available in CA - 30 ConverterKit (EDP 101-063-689). Instructions for installing must be adhered to and are included in the Installation Instructions.



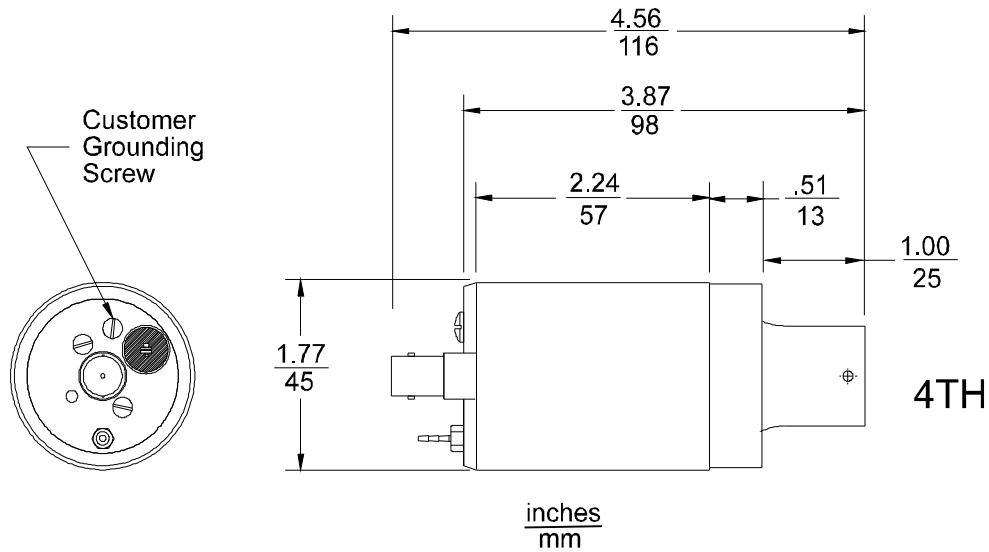
**Figure 5.8** 30 kHz Converter/Booster/Horn, Typical Dimensions



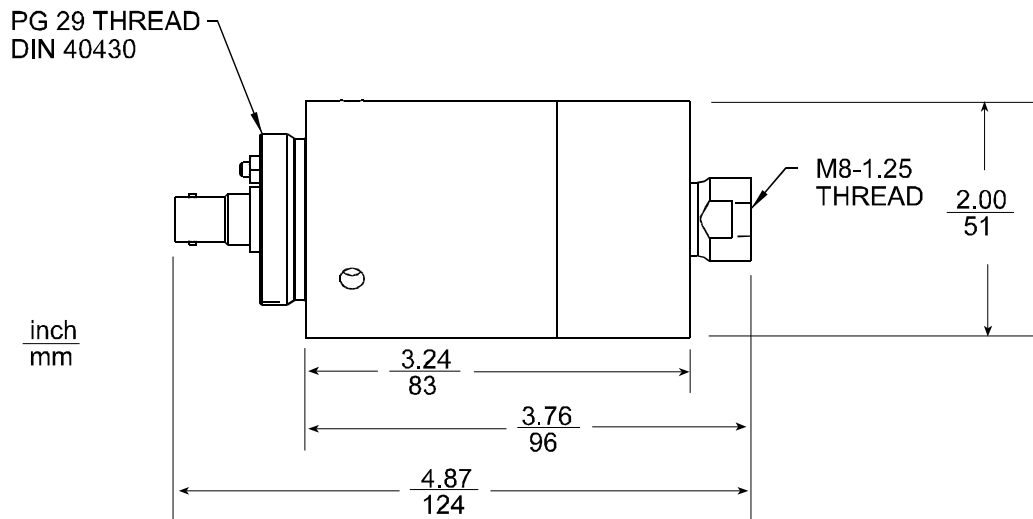
**Figure 5.9** 40 kHz, 4TR and 4TJ Converter Dimensions



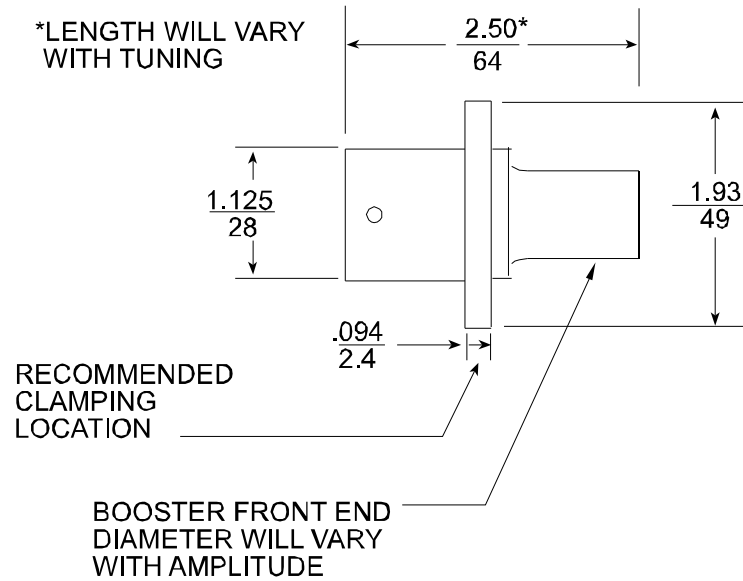
**Figure 5.10** 40 kHz, 4TH Converter Dimensions



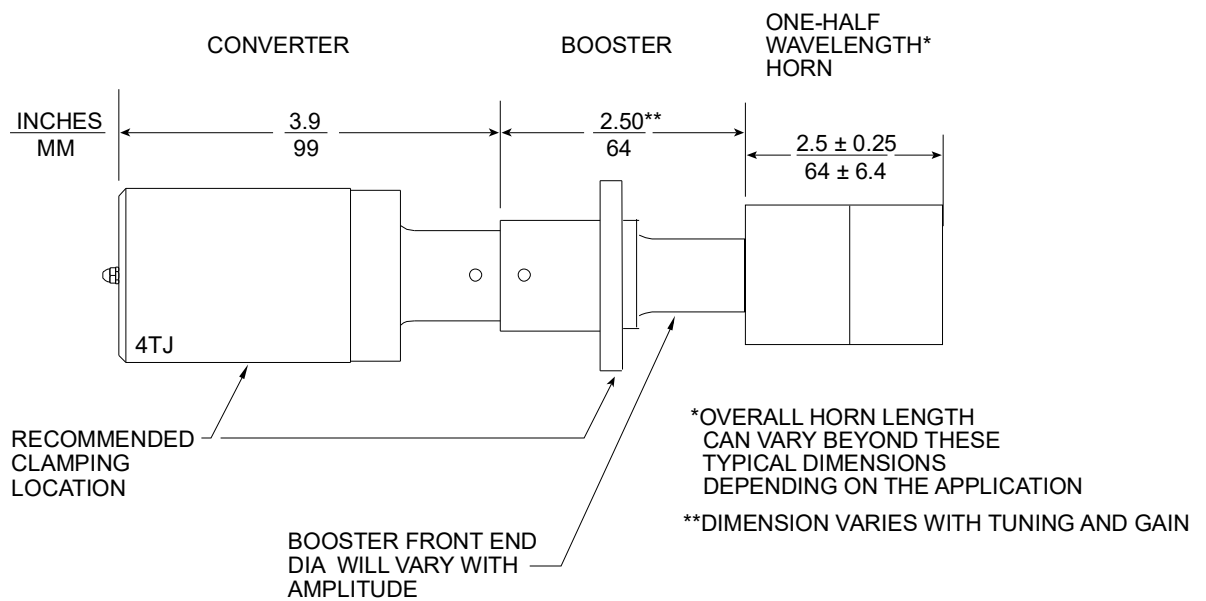
**Figure 5.11** 40 kHz, 4TP Converter Dimensions



**Figure 5.12** 40 kHz Booster Dimensions



**Figure 5.13** 40 kHz Converter/Booster/Horn, Typical Dimensions





## Chapter 6: Operation

<b>6.1</b>	<b>Front Panel Controls</b> . . . . .	<b>91</b>
<b>6.2</b>	<b>System Menus</b> . . . . .	<b>95</b>
<b>6.3</b>	<b>Setting Primary Parameters</b> . . . . .	<b>99</b>
<b>6.4</b>	<b>Setting Other Weld Parameters</b> . . . . .	<b>114</b>
<b>6.5</b>	<b>Saving and Recalling Presets</b> . . . . .	<b>137</b>
<b>6.6</b>	<b>Using the Diagnostics Menu</b> . . . . .	<b>147</b>
<b>6.7</b>	<b>Viewing System Information</b> . . . . .	<b>153</b>
<b>6.8</b>	<b>Using the System Configuration Menu</b> . . . . .	<b>156</b>
<b>6.9</b>	<b>Using the Horn Down Feature</b> . . . . .	<b>184</b>
<b>6.10</b>	<b>Using the Test Feature</b> . . . . .	<b>185</b>


### WARNING



High voltage is present in the 2000X Power Supply. When setting up and operating the welding system, observe the potential hazards listed below.

- Do not operate the Power Supply with the cover removed
- To prevent the possibility of electric shock, always plug the 2000X into a grounded power source
- Keep hands out from under the horn. Down-force (pressure) and ultrasonic vibrations can cause injury
- Large plastic parts can vibrate within the audible frequency range when welded. If this occurs, use hearing protectors to prevent possible injury
- Do not press the Test switch or cycle the welding system if either the RF cable or the converter is disconnected. High voltage could be present at open power connections
- When using larger horns, avoid situations in which fingers could be pinched between the horn and the fixture
- Assure power switch is in the OFF position before making or breaking any electrical or pneumatic connections to the Power Supply, Actuator or Welder

- Do not touch Ultrasonic Horn during or immediately following the welding cycle. Vibrations and heat can burn skin

CAUTION	
	Do not allow a vibrating horn to touch a metal base or metal fixture.

## 6.1 Front Panel Controls

You can use the keys and vacuum fluorescent display (VFD) on the front panel of the 2000X Power Supply to navigate through all of the menus, set welding values, view alarms, and information about the most recently completed weld.

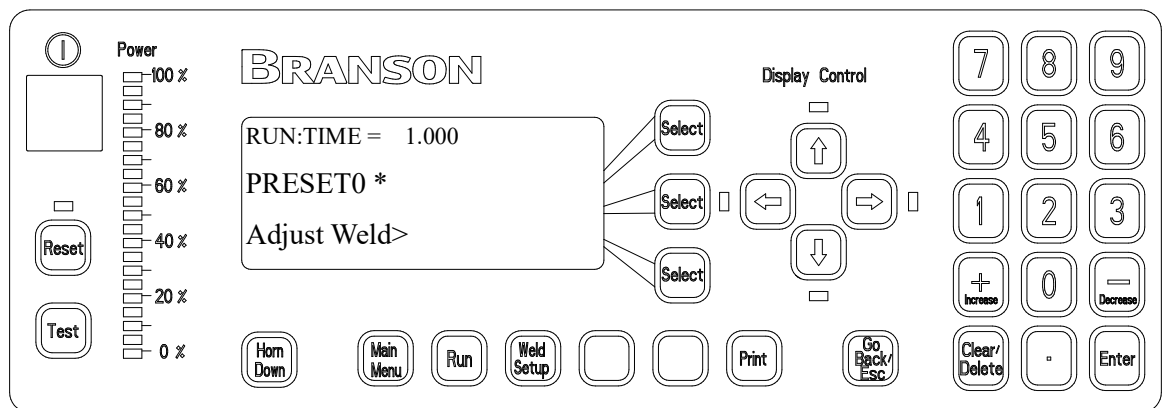
### 6.1.1 Front Panel Keypad and Indicators

You can perform the following navigational and operational functions on the Power Supply front panel:

- Select an item from a menu
- Change the value of a parameter using the numeric keypad
- Increase or decrease a parameter value incrementally
- Navigate up, down, right, and left through the items in each menu

This section details the navigation rules of the 2000X Power Supply.



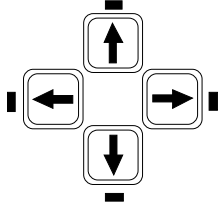
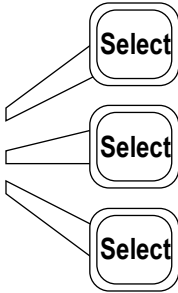



**Figure 6.1** Front Panel of the 2000X Power Supply




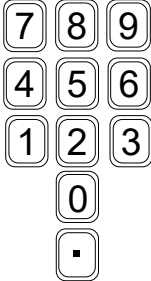





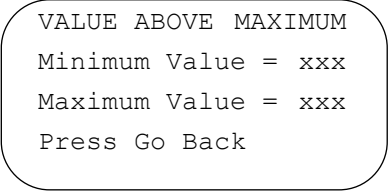
Any time that there is a light visible above, below, or next to a particular key on the front panel of the 2000X Power Supply, you can use that key to make a selection or navigate the menu that is shown on the display. Any time that you press a key that is not valid, you will hear an audible alarm if selected. This is not the type of alarm that will require you to reset the Power Supply.

Any time that a menu item has a caret symbol (>) shown at the end, you can press the Select key that corresponds to that menu item to see a submenu of further items. It is not necessary to press the Select key next to the Weld Results line. You can scroll through this menu by using the Right or Left Display Control keys. When a menu item has an equal sign (=) shown at the end, you can enter a numeric value for that item using the numeric keypad, or toggle to switch/select the respective function (i.e. Post Weld Seek = On). When you are changing a numeric value, you can either use the number keys on the numeric keypad or the + Increase and - Decrease keys on the numeric keypad. When you press the + Increase and - Decrease keys, the value that you are changing will be incremented or decremented by one unit of the smallest unit shown for that parameter.

**Table 6.1** Navigation through the 2000X Power Supply menus

Function	Key
To view the <b>Run</b> screen on the display at any time, press the <b>Run</b> key.	
To view the <b>Main</b> menu on the display at any time, press the <b>Main Menu</b> key.	
To navigate through a menu that has more selections than can be shown at one time, press one of the <b>Display Control Arrow</b> keys. Any time that you can press one of these keys, the LED next to the key is illuminated.	
There are three <b>Select</b> keys, each of which corresponds to one of the three menu items that are available to you at any given time. To select an item on any menu, press the <b>Select</b> key that corresponds to that item.	
When you have selected a particular parameter, you will see a blinking cursor next to the value of the parameter you selected. Press the <b>Select</b> key repeatedly to toggle between the minimum and maximum default values and Off if it can be disabled.	
From any submenu, including a particular Weld Mode menu, press the <b>Go Back/Esc</b> key to return to one level higher in the menu structure. You can also use the <b>Go Back/Esc</b> key to return to the previous value for a particular parameter if you have made a change to the value but do not want to accept the new value. This will remove the blinking cursor from the value for that parameter. Repeated pressing of <b>Go Back/Esc</b> returns you to the Main Menu.	
To decrease the numeric value of a parameter, select it using a <b>Select</b> key and press the <b>- Decrease</b> key.	

**Table 6.1** Navigation through the 2000X Power Supply menus

Function	Key
To increase the numeric value of a parameter, select it using a <b>Select</b> key and press the <b>+</b> <b>Increase</b> key.	
To enter a specific numeric value for a parameter, select it using a <b>Select</b> key and use the numeric keypad. Any time that you begin using the numeric keypad, you can no longer use the <b>Decrease</b> or <b>Increase</b> keys unless you first select the <b>Clear</b> key.	
To clear the entry field for a particular parameter, select it using a <b>Select</b> key and press the <b>Clear/Delete</b> key. The cursor remains in the most significant position of the field.	
Once you have made a change to the value of a parameter in a menu, press the <b>Enter</b> key on the numeric keypad to accept the value. This removes the blinking cursor from the value for that parameter.	
When you encounter an alarm condition requiring that you reset the Power Supply before performing another weld operation, press the <b>Reset</b> key.	
When you want to check the position of your fixture by bringing the horn down to the part with no ultrasonics, press the <b>Horn Down</b> key. System Pressure setting is viewable in the display screen.	
To view the <b>Weld Setup</b> menu at any time on the display, press the <b>Weld Setup</b> key.	
If you enter a value for a parameter that is above the maximum or below the minimum allowed for that parameter, you will hear a beep and you will see the message shown at the right. Press the <b>Go Back/Esc</b> key to return to the parameter in question. Enter a valid value for the parameter and continue.	

## 6.1.2 Testing the Welding System

After the Power Supply is installed, you can confirm that the ultrasonic welding system is operational by following this test procedure using a sample part. This assumes that the installation has been set-up and tested per [Chapter 4: Installation and Setup](#) of this manual.

**To test the Welding System after installation, do the following:**

**Table 6.2** Testing the Welding System after installation

Step	Action
1	On the Actuator column, adjust the stroke length to 1/4 inch or more, depending on the part you will use for the test run. Position the system to allow for a minimum stroke length of 1/8 inch or more. Lock column after adjusting.
2	Position the part in the tooling.
3	Verify that factory air supply has been connected to the actuator and turned on. (If using optional pneumatic dump valve, ensure it is turned on.)
4	On the Power Supply front panel, press the power switch. The power light on the front of the Actuator becomes illuminated.
5	On the actuator, using the Dynamic Trigger knob, set the trigger force to 2.
6	On the actuator, using the Downspeed knob, set the downspeed control to 10.
7	On the actuator, using the air pressure regulator knob, set the air pressure to 25 psi. To do this, pull the knob, rotate it clockwise to increase the air pressure and push it to lock.
8	The display should now read "Run". If the power supply displays an alarm message, find the alarm message definition, cause, and correction in <a href="#">Chapter 7: Maintenance</a> of this manual. If the alarm message is Recalibrate Actuator, return to <a href="#">Chapter 4: Installation and Setup</a> , and re-run the procedure in <a href="#">4.10 Installing the Ultrasonic Stack in the Actuator</a> .
9	On the Power Supply front panel, press the Run key.
10	Activate both Start Switches simultaneously, or activate your Start Signal if you are using the system in automation.
11	When the weld cycle is complete, and if the cycle has completed successfully, the cycle counter increments to show a completed cycle. The top line of the Run screen displays: RUN:XXX= whether or not the cycle was successfully completed. If the Reset LED on the Power Supply front panel flashes and the second line displays an alarm message, the test did not complete successfully. See Section <a href="#">7.5 System Alarm Tables</a> , for information on alarm conditions and how to correct them.

## 6.2 System Menus

### 6.2.1 Using the Run Screen

The **Run Screen** is a set of information displayed on the 2000X Power Supply; it shows weld status, alarms, weld count, and process information. The Run Screen appears as shown below.

```
RUN: TIME =30.000
Preset1 ABCDE123456
Adjust Weld>
Weld Results>
```

The first line of the Run Screen shows current welding mode and value of the main parameter. For example, on the Run Screen shown above, the weld mode is Time Mode and the Time is set to 30 seconds.

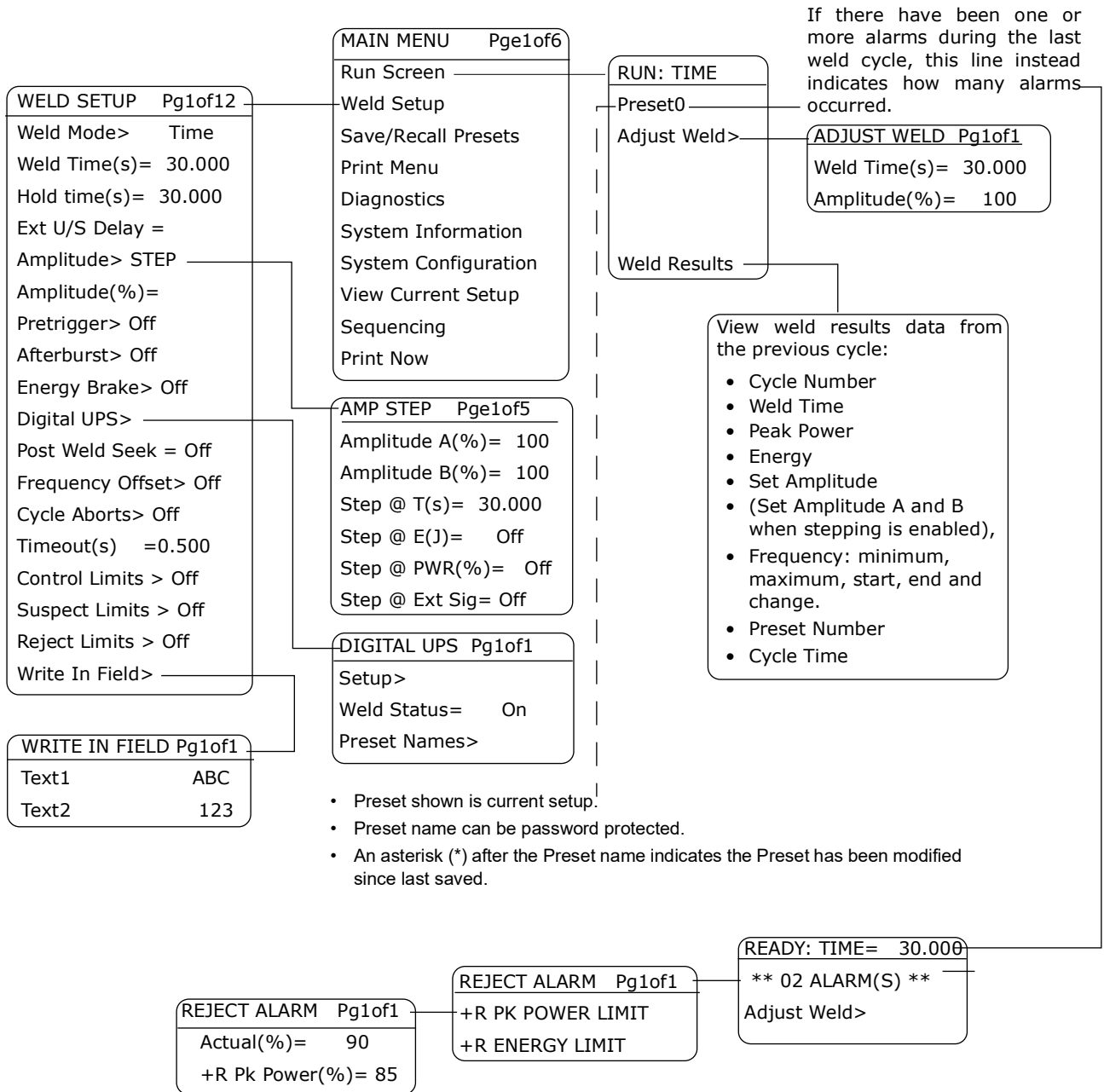
From the Run Screen you can observe the status of a weld cycle while it is in process. The first line cycles through the following Weld States during a weld cycle:

```
RUN: TIME =30.000
VERIFYING PRESET
EXTENDING
WELDING
HOLDING
AFTERBURST DELAY
AFTERBURST
POST SEEKING
RETRACTING
PRINTING
RUN: TIME =30.000
```

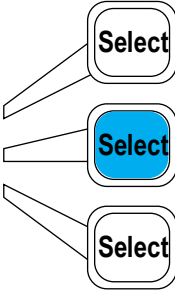
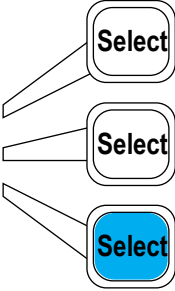
- **READY** indicates that the welder is ready to start a new cycle
- **EXTENDING** indicates that the actuator is approaching your part
- **VERIFYING PRESET** is verifying the preset you are using and the settings associated with it. This state is only displayed on the first cycle after you change a parameter
- **EXTENDING** indicates that the horn is in its down stroke
- **WELDING** indicates that ultrasonics are on
- **HOLDING** indicates that ultrasonics have turned off and pressure remains on your part. This shows only if this parameter is turned on
- **AFTERBURST DELAY** is shown only if you have set this parameter to ON, and indicates that the hold step has ended but the afterburst has not begun
- **AFTERBURST** is shown only if you have set this parameter to ON, and indicates that the afterburst of ultrasonics is on during the up stroke
- **POST SEEKING** is shown only if you have set this parameter to ON, and indicates that the Power Supply is running a 5% amplitude cycle to find its operating frequency
- **RETRACTING** indicates that the actuator is returning to the home position
- **PRINTING** is Not supported in Power Supplies manufactured since April 2025. See [Appendix C: Manual Revisions](#) for information on manufacture dates.

The following page contains a map of the menu options available from the Run Screen. Following the map is a procedure to adjust the Weld Setup and view the weld results from the Run Screen.

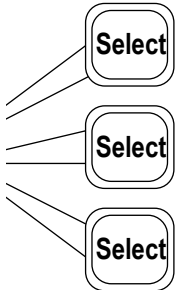
## 2000X ea Power Supply Main Menu: Run Screen



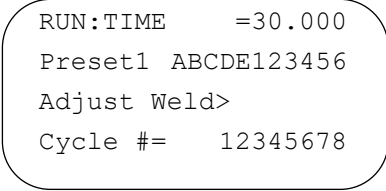
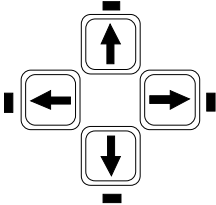
**Table 6.3** Adjusting the Weld Setup from the Run Screen

Take this action	To get this result	Key
<p>Press the <b>Select</b> key that corresponds to <b>Adjust Weld</b> on the <b>Run Screen</b>.</p>	<pre data-bbox="878 464 1263 653">                     RUN:TIME      =30.000                     Preset1 ABCDE123456                     Adjust Weld&gt;                     Weld Results&gt;                 </pre>	
<hr/>		
<p>You will see the <b>Adjust Weld</b> submenu.</p> <p><b>NOTICE</b> The <b>Weld Time(s)</b> line of the <b>Adjust Weld</b> submenu is determined by the currently selected <b>Weld Mode</b> (for example, in <b>Energy Mode</b>, this line would read "Weld Energy (J = xx)"). From this submenu, you can adjust the <b>Weld Time or Amplitude</b> parameters directly. If you wish to change any other weld parameters, press the <b>Weld Setup</b> key for a full setup menu.</p>	<pre data-bbox="878 856 1263 1045">                     ADJUST WELD  Pg1of1                     Weld Time(s) =30.000                     Amplitude(%)= 100                 </pre>	

**Table 6.4** Viewing Weld Results

Take this action	To get this result	Key
<p>Press the <b>Run</b> key to go to the <b>Run Screen</b>.</p>	<pre data-bbox="846 1602 1230 1791">                     RUN:TIME      =30.000                     Preset1 ABCDE123456                     Adjust Weld&gt;                     Weld Results&gt;                 </pre>	

**Table 6.4** Viewing Weld Results

Take this action	To get this result	Key
<p>You will see the LEDs next to the left and right arrows illuminated on the <b>Display Control</b> panel. You can press these keys to scroll right or left through a series of parameters that reflect the status of the most recent weld cycle.</p>	 <pre> RUN:TIME      =30.000 Preset1 ABCDE123456 Adjust Weld&gt; Cycle #=      12345678                     </pre>	

On the bottom line of the display, you can scroll through the following Weld Results parameters:

- Cycle#:** the number of the last cycle completed
- Time(s):** the actual length of time the ultrasonics was on during the most recent weld cycle
- Pk Pwr(%):** the percentage of peak power of the most recent weld
- Energy (J):** the energy that was used in the most recent weld
- Set Amp (%):** The set value for amplitude of the most recent weld when amplitude stepping is off
- Set Amp A (%):** (Does not appear when stepping is enabled.) The set value for amplitude during the first part of the weld before reaching the step point when amplitude stepping is on
- Set Amp B (%):** (Does not appear when stepping is enabled.) The set value for amplitude during the second part of the weld after reaching the step point when amplitude stepping is on
- Freq Min(Hz):** the minimum frequency used during the most recent weld cycle
- Freq Max(Hz):** the maximum frequency used during the most recent weld cycle
- Freq Start(Hz):** the frequency at the start of the most recent weld cycle
- Freq End(Hz):** the frequency at the end of the most recent weld cycle
- Freq Chg(Hz):** the change in frequency during the most recent weld cycle


## 6.3 Setting Primary Parameters

After analyzing your specific application, you can determine the Weld Mode to use to weld your parts. A Weld Mode is a set of parameters that governs the weld. (Contact the Branson Ultrasonics Applications Laboratory for more information on determining the best mode for welding your application. See [1.4 How to Contact Branson.](#))

There are four Weld Modes to choose from Time, Energy, Peak Power, and Ground Detect Modes. The following table describes each mode:

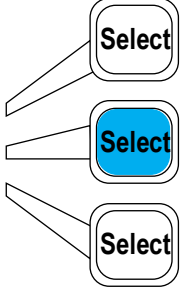
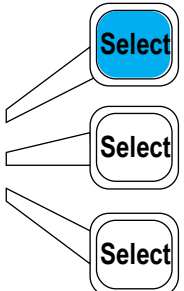
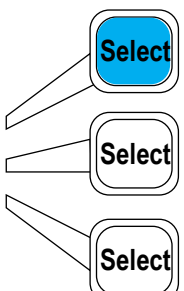

**Table 6.5** Summary of Weld Modes

Weld Mode	Description
Time	You select the length of time (in seconds) that ultrasonic energy will be transmitted to your parts.
Energy*	You select the amount of energy (in Joules) that will be transmitted to your parts. (A Joule is one watt per second.)
Peak Power*	You select the peak power level (as a percentage of full power) at which the weld is terminated.
Ground Detect*	The 2000X provides ultrasonic energy until the horn comes in contact with your electrically isolated fixture or with the anvil, providing that you made an electrical connection between the actuator and your fixture or anvil.

NOTICE	
	*In these modes, timeout can be used for control limits.

To select a Weld Mode, use the keys adjacent to the LED display on the front panel of the Power Supply.

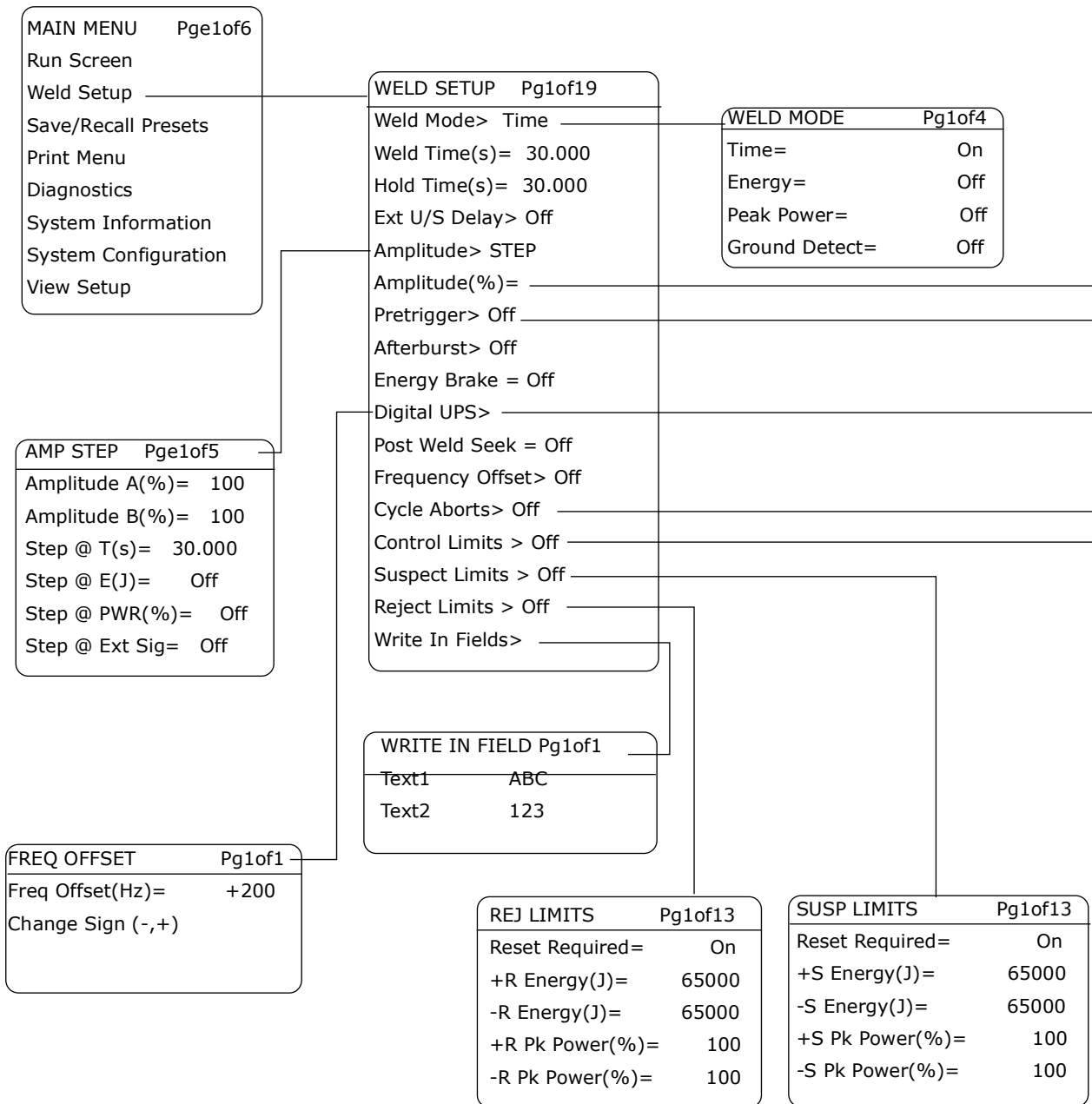
**Table 6.6** Selecting a Weld Mode

Take this action	To get this result	Key
<p>Press the <b>Select</b> key that corresponds to <b>Weld Setup</b> or <b>press the Weld Setup key</b>. The mode that appears is always the mode that you used most recently.</p>	<pre>MAIN MENU    Pg1of6 Run Screen&gt; Weld Setup&gt; Save/Recall Presets</pre>	
<p>Press the <b>Select</b> key that corresponds to <b>Weld Mode&gt;</b>.</p>	<pre>WELD SETUP  Pg1of19 Weld Mode&gt;   Time Weld Time(s) = 0.010 Hold Time (s) =0.010</pre>	
<p>Use the up and down arrow keys on the <b>Display Control</b> panel to scroll through the <b>Weld Mode</b> menu. Press the <b>Select</b> key that corresponds to the Weld Mode that you want to use.</p>	<pre>WELD MODE    Pg1of4 Time          =On Energy        =Off Peak Power    =Off</pre>	
<p>Press <b>Enter</b> on the numeric keypad to save the new weld mode, or press <b>Go Back/Esc</b> to make no change to the weld mode.</p>	<pre>TIME MODE    Pg1of19 Weld Mode&gt;   Time Weld Time(s)=30.000 Hold Time(s) = 0.010</pre>	

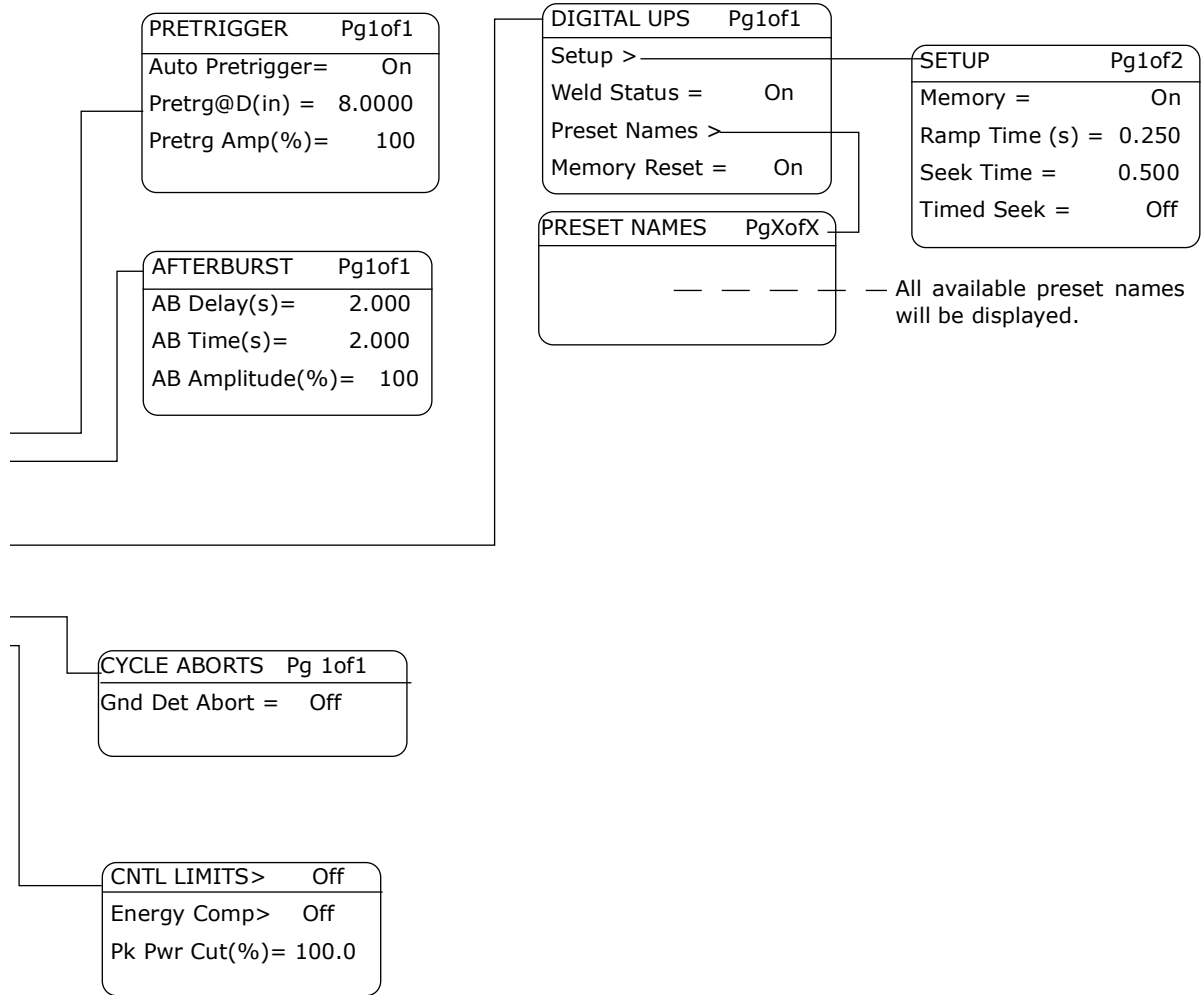
## 6.3.1 Using Time Weld Mode

You can use Time Mode to select the length of time that ultrasonic energy is applied to your parts. Within Time Mode, you can also select several other parameters, ranging from Hold Time (in seconds) to Suspect and Reject Limits. The following two pages contain a map of the menu options in Time Mode. Procedures for setting primary parameters follow the map. For more information on setting the optional parameters within Time Mode, or any other welding mode, see [6.4 Setting Other Weld Parameters](#).

### 2000X ea Power Supply Main Menu: Weld Setup (Time Mode)



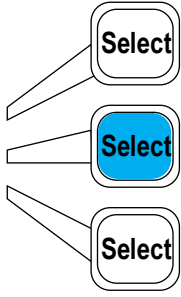
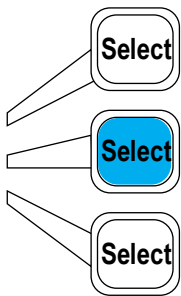

Note that values may vary with models and equipment.



## Setting Weld Time

You can select the length of time (in seconds) that ultrasonic energy will be transmitted to your parts.

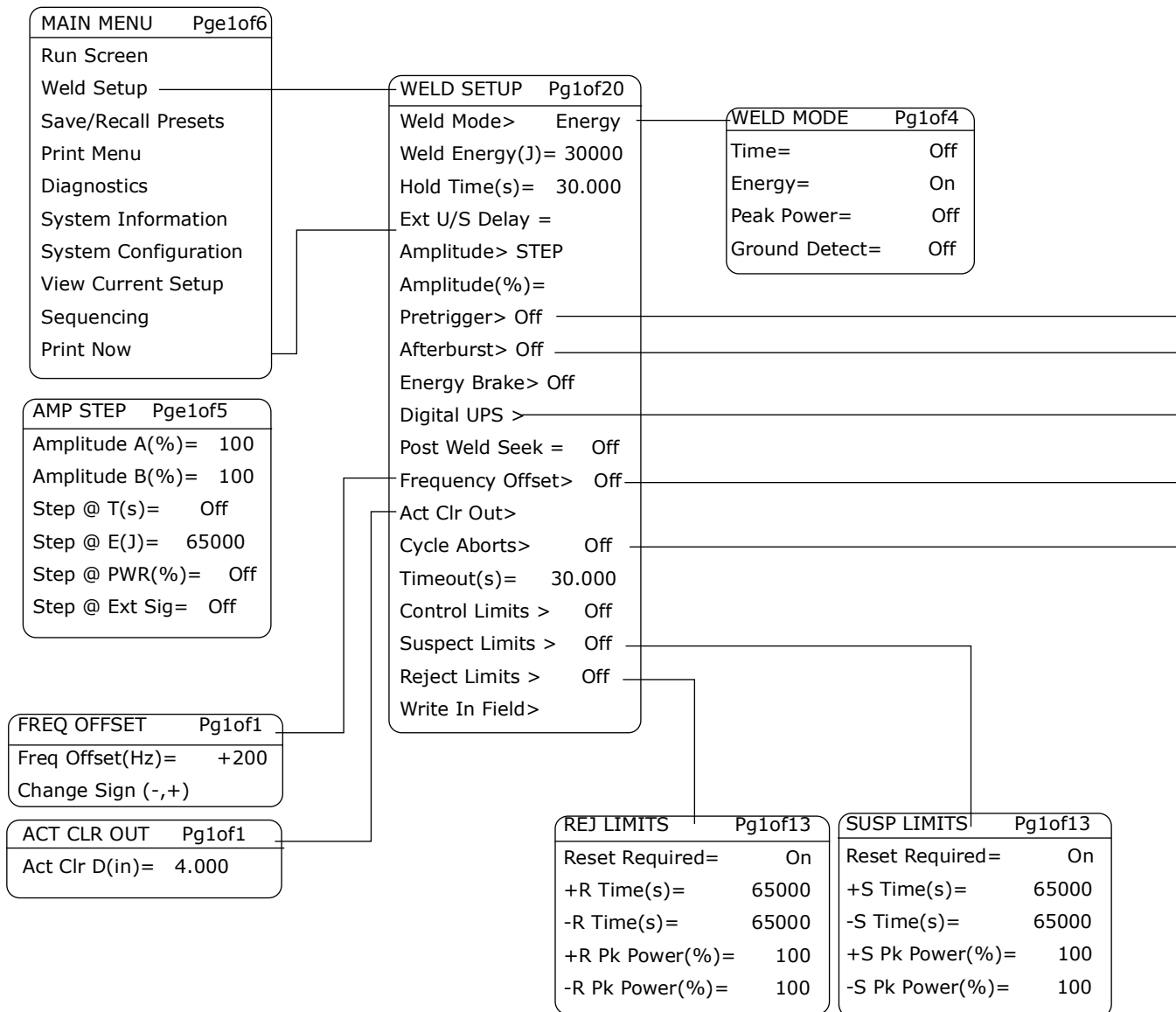
**Table 6.7** Setting Welding Time

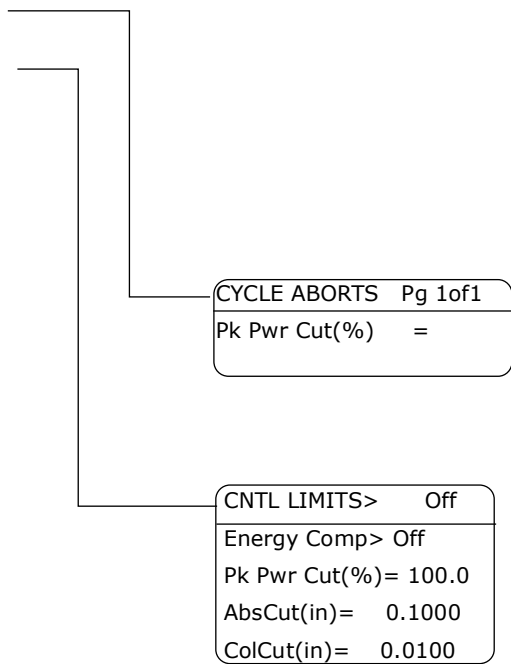
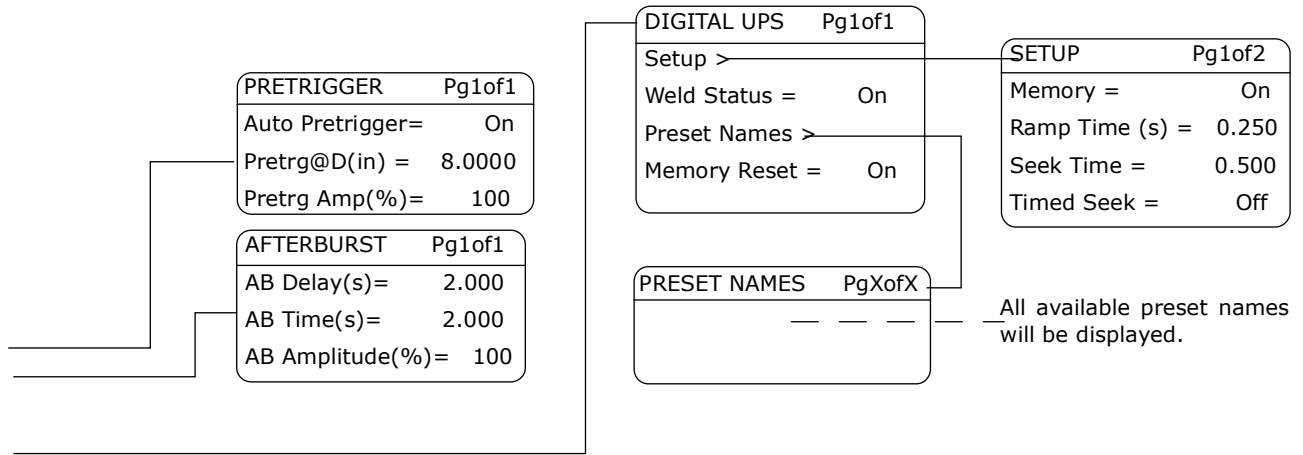
Take this action	To get this result	Key
<p>Press the <b>Select</b> key that corresponds to <b>Weld Time(s)</b>.</p>	<pre>WELD SETUP  Pg1of13 Weld Mode&gt;   Time Weld Time(s)= 0.010 Hold Time(s)= 0.010</pre>	
<p>Use the numeric keypad to enter the <b>Weld Time</b> (in seconds) that you want to use, or press the same <b>Select</b> key repeatedly to toggle between the minimum (0.010 second) and maximum (30.000 seconds) values for <b>Weld Time</b>.</p>	<pre>WELD SETUP  Pg1of13 Weld Mode&gt;   Time Weld Time(s)= 1.500 Hold Time(s)= 0.010</pre>	
<p>Press <b>Enter</b> on the numeric keypad to save the new value, or press <b>Go Back/Esc</b> to make no change to the value.</p>	<pre>WELD SETUP  Pg1of13 Weld Mode&gt;   Time Weld Time(s)= 1.500 Hold Time(s)= 0.010</pre>	

## 6.3.2 Using Energy Weld Mode

You can use Energy Mode to select the amount of ultrasonic energy that is applied to your parts. Within Energy Mode, you can also select several other parameters, ranging from Hold Time (in seconds) to Suspect and Reject Limits. The following two pages contain a map of the menu options in Energy Mode. Procedures for setting primary parameters follow the map. For more information on setting the optional parameters within Energy Mode, or any other welding mode, see [6.4 Setting Other Weld Parameters](#).

### 2000X Power Supply Main Menu: Weld Setup (Energy Mode)

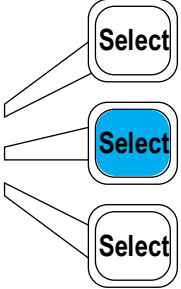
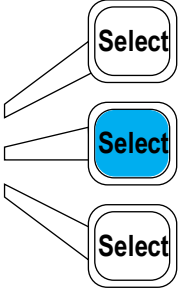





## Setting Weld Energy

You can select the amount of ultrasonic energy (in Joules) that will be transmitted to your parts.

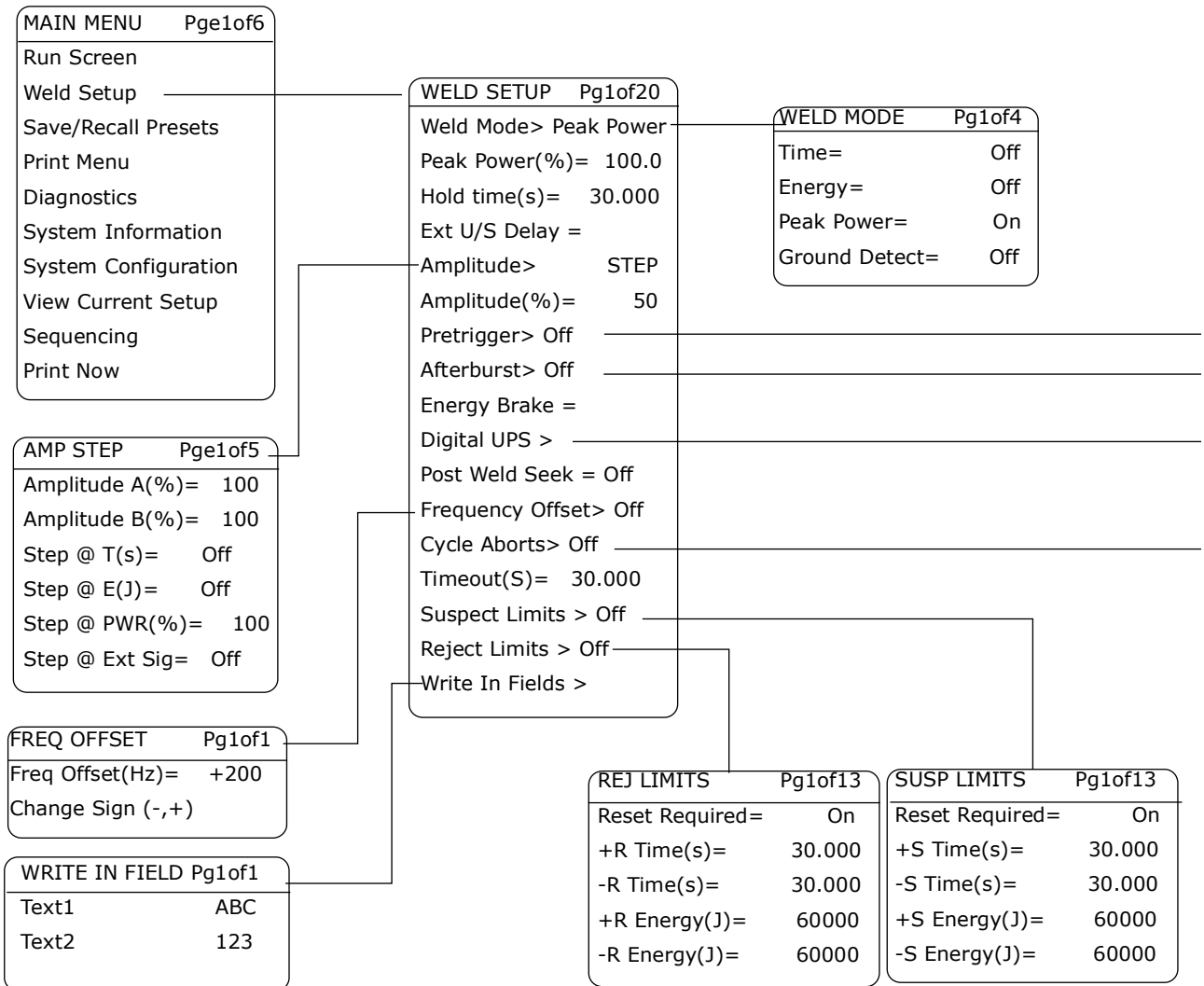
**Table 6.8** Setting Weld Energy

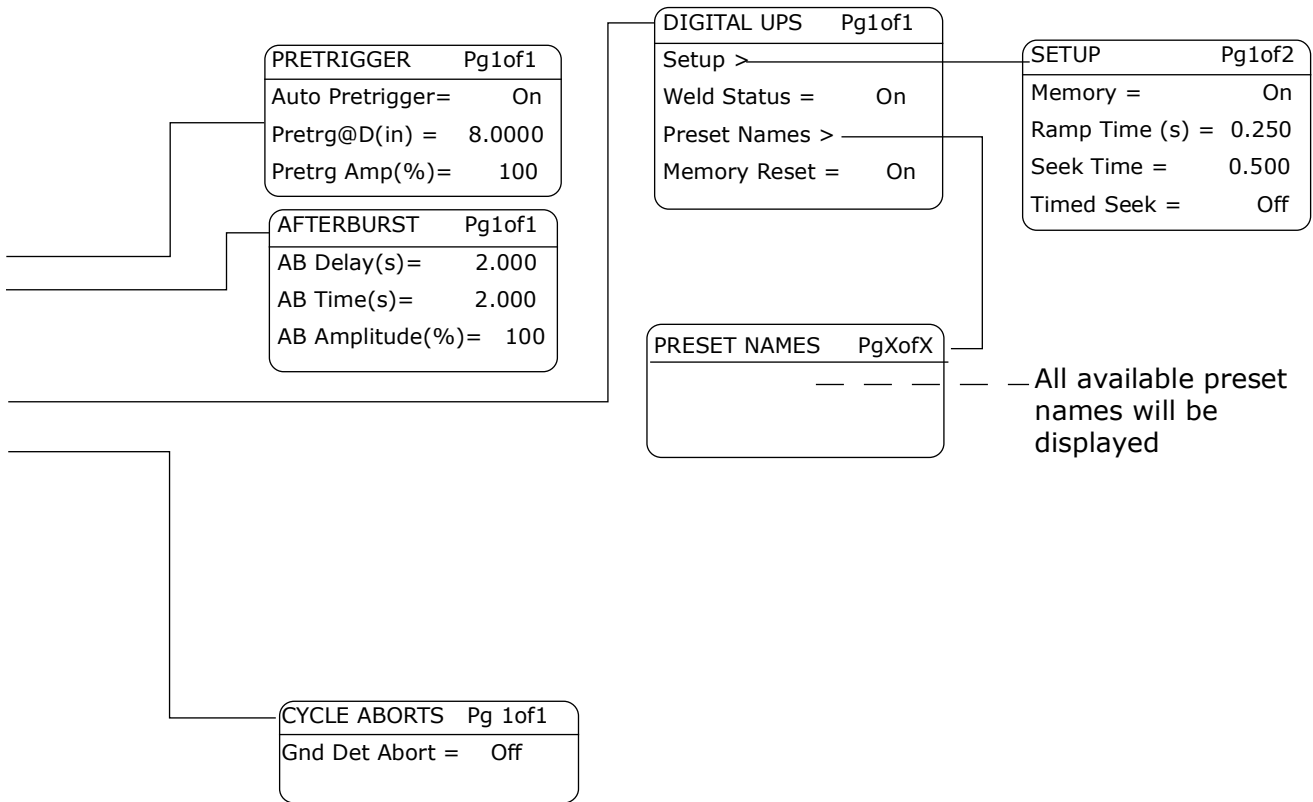
Take this action	To get this result	Key
<p>Press the <b>Select</b> key that corresponds to <b>Weld Energy(J)</b>.</p>	<pre> WELD SETUP   Pg1of20 Weld Mode&gt;   Energy Weld Energy(J)=30000 Hold Time (s)=30.000                     </pre>	
<p>Use the numeric keypad to enter the <b>Weld Energy</b> (in Joules) that you want to use, or press the same <b>Select</b> key again to toggle between the minimum value (1.0 joule) and the maximum value (66000 joules) for <b>Weld Energy</b>.</p>	<pre> WELD SETUP   Pg1of20 Weld Mode&gt;   Energy Weld Energy(J)= 150 Hold Time(s)= 30.000                     </pre>	
<p>Press <b>Enter</b> on the numeric keypad to save the new value, or press <b>Go Back/Esc</b> to make no change to the value.</p>	<pre> WELD SETUP   Pg1of20 Weld Mode&gt;   Energy Weld Energy(J)= 150 Hold Time(s)= 30.000                     </pre>	

## 6.3.3 Using Peak Power Weld Mode

You can use Peak Power Mode to select the maximum percentage of the total available power that will be used to process your welds. When the power level you set is reached, ultrasonics will be terminated. From within Peak Power Mode, you can also select several other parameters, ranging from Hold Time (in seconds) to Suspect and Reject Limits. The following two pages contain a map of the menu options in Peak Power Mode. Procedures for setting primary parameters follow the map. For more information on setting the optional parameters within Energy Mode, or any other welding mode, see [6.4 Setting Other Weld Parameters](#).

### 2000X Power Supply Main Menu: Weld Setup (Peak Power Mode)

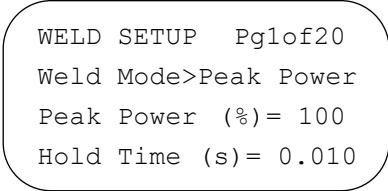
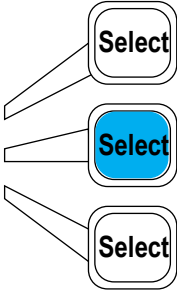
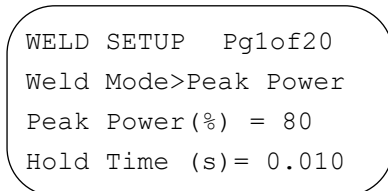
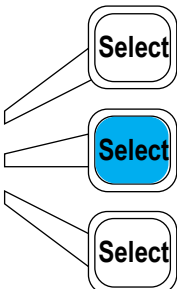
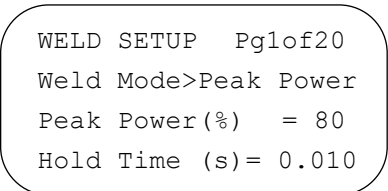





## Setting the Percentage of Peak Power

You can select the maximum percentage of available power that you want to be transmitted to your part. When this power level is reached, ultrasonics will be terminated.

**Table 6.9** Setting the percentage of Peak Power

Take this action	To get this result	Key
<p>Press the <b>Select</b> key that corresponds to <b>Peak Power (%)</b>.</p>	 <pre> WELD SETUP Pg1of20 Weld Mode&gt;Peak Power Peak Power (%) = 100 Hold Time (s) = 0.010           </pre>	
<p>Use the numeric keypad to enter the <b>Peak Power</b> (as a percentage) that you want to use, or press the same <b>Select</b> key repeatedly to toggle between the minimum value (1%) and the maximum value (100%) for <b>Peak Power</b>.</p>	 <pre> WELD SETUP Pg1of20 Weld Mode&gt;Peak Power Peak Power (%) = 80 Hold Time (s) = 0.010           </pre>	
<p>Press <b>Enter</b> on the numeric keypad to save the new value, or press <b>Go Back/Esc</b> to make no change to the value.</p>	 <pre> WELD SETUP Pg1of20 Weld Mode&gt;Peak Power Peak Power (%) = 80 Hold Time (s) = 0.010           </pre>	


## 6.3.4 USB

The two USB ports available on the 2000X power supply are USB 2.0 compliant, allowing complete plug and play, and hot attach/detach for up to 127 external devices. USB 2.0 is fully backward compatible with USB 1.1, supporting speeds of 1.5, 12 and 480 Mbps. For example, keyboard and mouse can be used with USB port at low speed, while USB memory stick will run at High-speed. Information can be transferred to a PC using the Branson History Utility to view and process information. This can be useful when weld history data requirements exceed the maximum of 50 weld history data that can be stored in the power supply.


To download data and graphs, a memory stick must be inserted into the USB port (or hub). Then activate the communication through the touch screen Main Menu:

- Enter the System Configuration menu. Located on the first screen is the USB DATA button
- Once in this menu, you need to switch the USB to On
- Select the weld data or graphs you would like to download. When selecting these, the user has the option of either downloading after a weld cycle (and at what interval, i.e., 1, 5, 20, 100, etc.) and/or when an alarm takes place

The storage capacity of the memory stick will determine the number of cycles and graphs the stick can hold. The data space required for each weld cycle is: 1.0 KB for weld data and 1.35 KB for each graph.

NOTICE	
	It is important to remember to turn off the USB feature prior to removing the memory stick; an alarm will be generated if the stick is simply removed.

To view the stored data on a PC you may use Branson's history utility program History.exe. (See the following section for further information.)

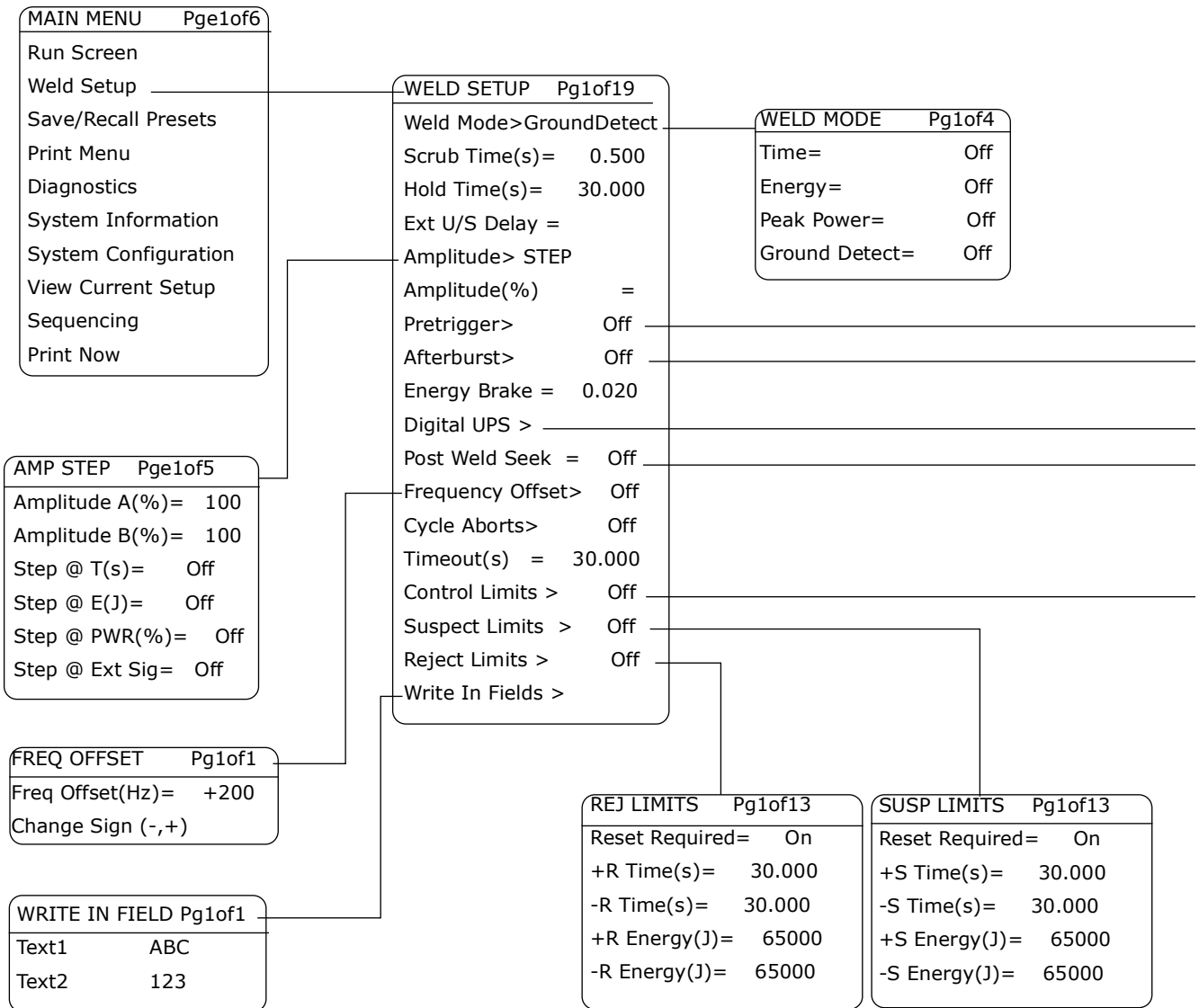
NOTICE	
	If data is not being saved, confirm your USB stick is set to drive D:.

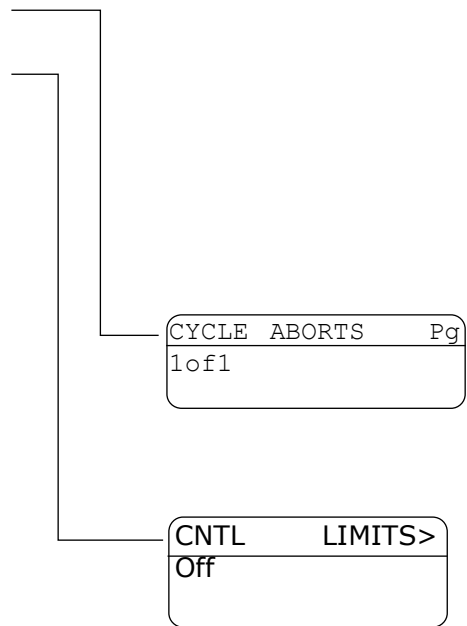
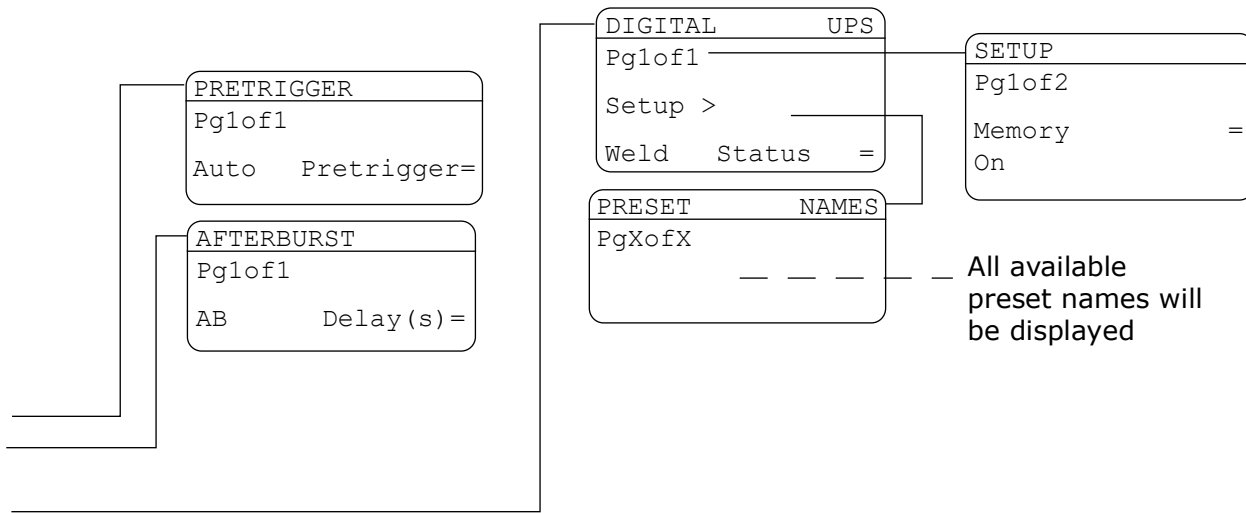
## 6.3.5 Using Ground Detect Weld Mode

You can use Ground Detect Weld Mode to have ultrasonic energy turn off when the horn comes in contact with your electrically isolated fixture or anvil. It is necessary to install Branson cable EDP No. 100-246-630 from the MPS/GDS receptacle on the rear of the actuator to your isolated fixture/anvil in order to utilize this feature.

From within Ground Detect Mode, you can also select several other parameters, ranging from Hold Time (in seconds) to Suspect and Reject Limits. The following two pages contain a map of the menu options in Ground Detect Mode. Procedures for setting primary parameters follow the map. For more information on setting the optional parameters within Ground Detect Mode, or any other welding mode, see [6.4 Setting Other Weld Parameters](#).


### 2000X Power Supply Main Menu: Weld Setup (Ground Detect Weld Mode)



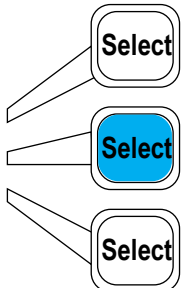
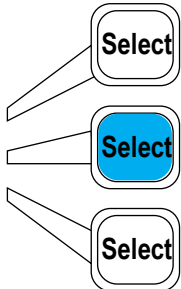



## Setting Scrub Time

You can select the amount of time you want to elapse between detection of a ground condition and the termination of ultrasonics.

NOTICE	
	<p>Your must have Ground Detect Cable EDP No. 100-246-630 installed to utilize the ground detect feature. It connects from the MPS/GDS receptacle on the rear of the actuator to the electrically isolated fixture/anvil.</p>

**Table 6.10** Setting Scrub Time

Take this action	To get this result	Key
<p>Press the <b>Select</b> key that corresponds to <b>Scrub Time(s)</b>.</p>	<pre>WELD SETUP Pg1of20 Weld Mode&gt;Gnd Detect Scrub Time(s)=0.500 Hold Time(s)=30.000</pre>	
<p>Use the numeric keypad to enter the <b>Scrub Time</b> (in seconds) that you want to use, or press the same <b>Select</b> key repeatedly to toggle between the minimum value (.001 second) and the maximum value (0.500 second) for <b>Scrub Time</b>.</p>	<pre>WELD SETUP Pg1of20 Weld Mode&gt;Gnd Detect Scrub Time(s)=0.100 Hold Time(s)=30.000</pre>	
<p>Press <b>Enter</b> on the numeric keypad to save the new value, or press <b>Go Back/Esc</b> to make no change to the value.</p>	<pre>WELD SETUP Pg1of20 Weld Mode&gt;Gnd Detect Scrub Time(s)=0.100 Hold Time(s)=30.000</pre>	

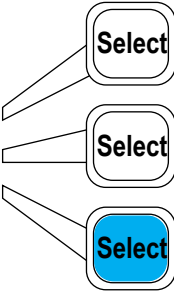
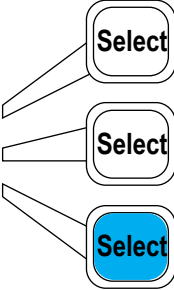

## 6.4 Setting Other Weld Parameters

From within each individual welding mode, you can also select several other parameters, including Amplitude (%), Pretrigger, Afterburst, Post Weld Seek, Frequency Offset, Control Limits, Cycle Aborts, and Suspect and Reject Limits. This section describes each of these parameters and the procedures for setting them.

### Setting Hold Time

You can select the duration (in seconds) of the Hold step (the step during which there is no ultrasonic energy transmitted to your part, but pressure is maintained) in welding your parts, or select not to have a Hold Time.

**Table 6.11** Setting Hold Time

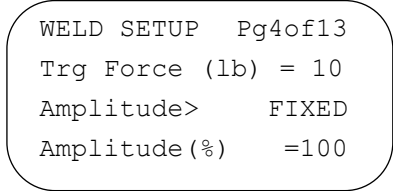
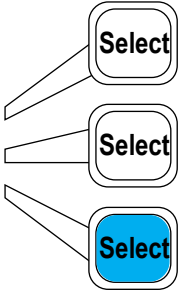
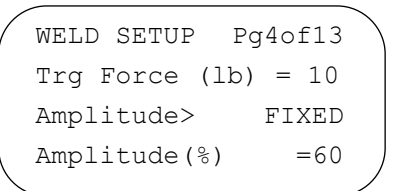
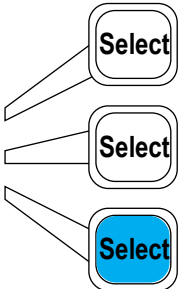
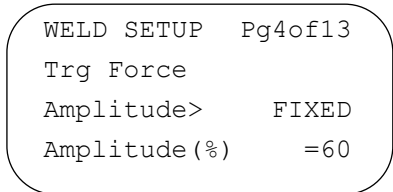

Take this action	To get this result	Key
<p>Press the <b>Select</b> key that corresponds to <b>Hold Time(s)</b>.</p>	<pre> WELD SETUP  Pg1of13 Weld Mode&gt;   Time Weld Time(s) = 1.500 Hold Time(s) = 0.100                     </pre>	
<p>Use the numeric keypad to enter the <b>Hold Time</b> (in seconds) that you want to use, or press the same <b>Select</b> key repeatedly to toggle between the minimum value (0.010 second), and the maximum value (30.000 seconds) for <b>Hold Time or Off to disable the Hold Time</b>.</p>	<pre> WELD SETUP  Pg1of13 Weld Mode&gt;   Time Weld Time =   1.500 Hold Time(s) = 0.100                     </pre>	
<p>Press <b>Enter</b> on the numeric keypad to save the new value, or press <b>Go Back/Esc</b> to make no change to the value.</p>	<pre> WELD SETUP  Pg1of13 Weld Mode&gt;   Time Weld Time(s) = 1.500 Hold Time(s) = 0.100                     </pre>	

## Setting Amplitude (%)

You can set the amplitude of the ultrasonic energy that will be delivered in any welding mode. The Power Supply's default is to use 100% of the available amplitude. By changing the amplitude to some lesser percentage of the total available, or by setting the amplitude to begin at one level and finish at another, you can "fine tune" your overall welding procedure without making changes to your tooling (converter, booster, horn, or fixture).

You can select the amplitude to use when Amplitude is fixed. If Amplitude is Stepped, this parameter is inactive and the display shows \*\*\*\* for Amplitude (%). If you set Amplitude Control to External in System Configuration, this parameter is inactive and the display shows Ext for Amplitude (%).

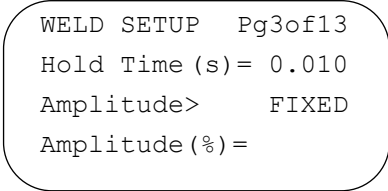
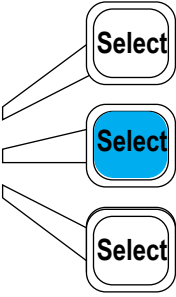
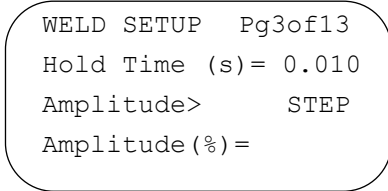
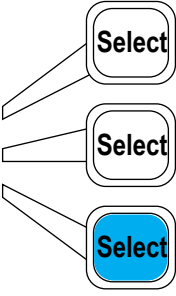
**Table 6.12** Setting Amplitude (%)

Take this action	To get this result	Key
<p>Using the arrow keys, scroll downward through the menu until you see <b>Amplitude (%)</b>. Press the <b>Select</b> key that corresponds to <b>Amplitude (%)</b>.</p>		
<p>Use the numeric keypad to enter the <b>Amplitude</b> (as a percentage of the maximum) that you want to use, or press the same <b>Select</b> key repeatedly to toggle between the minimum value (10%) and the maximum value (100%) for <b>Amplitude (%)</b>.</p>		
<p>Press <b>Enter</b> on the numeric keypad to save the new value, or press <b>Go Back/Esc</b> to make no change to the value.</p>		








## Setting Stepped Amplitude


You can select whether you want to apply a fixed or stepped amplitude to the part during welding. If you choose to use a stepped amplitude, you must also choose the first and second amplitudes (each as a percentage of the maximum) to use before and after the step point, as well as the criteria to use to step.

**Table 6.13** Setting Stepped Amplitude

Take this action	To get this result	Key
<p>Using the arrow keys, scroll downward through the menu until you see <b>Amplitude</b>. Press the <b>Select</b> key that corresponds to <b>Amplitude</b>.</p>	 <pre> WELD SETUP Pg3of13 Hold Time (s)= 0.010 Amplitude&gt;     FIXED Amplitude(%)=                     </pre>	
<p>Press the same <b>Select</b> key again to toggle between FIXED and STEP.</p>	 <pre> WELD SETUP Pg3of13 Hold Time (s)= 0.010 Amplitude&gt;     STEP Amplitude(%)=                     </pre>	
<p>Press <b>Enter</b> on the numeric keypad to save the new value, or press <b>Go Back/Esc</b> to make no change to the value.</p>		

**Table 6.13** Setting Stepped Amplitude

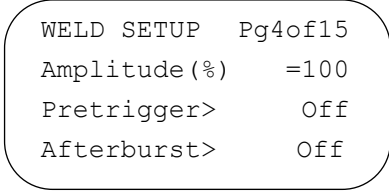
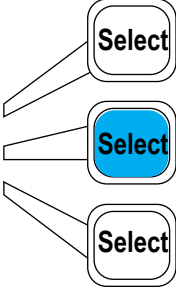
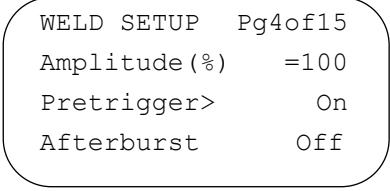
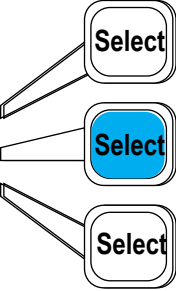
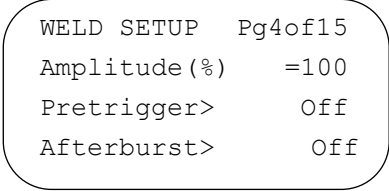
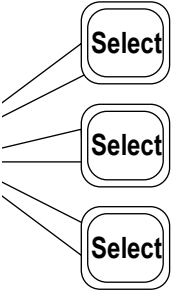
Take this action	To get this result	Key
<p>If you chose STEP, use the <b>Select</b> keys and the numeric keypad to enter the values you want to use as limits before and after the step (where A is before and B is after).</p> <p>Pressing the <b>Select</b> key that corresponds to one of the following limits, to select the criteria for stepping:</p> <ul style="list-style-type: none"> <li>T (s): time (in seconds)</li> <li>E (J): energy level (in Joules)</li> <li>Pwr(%): percentage of peak power</li> <li>Ext Sig: whether an external signal will be used to trigger the amplitude step (see note).</li> </ul> <p>Press the <b>Go Back/Esc</b> key to exit the submenu.</p>	<div style="border: 1px solid black; border-radius: 15px; padding: 10px; margin-bottom: 20px;"> <p>AMP STEP Pg1of4            Amplitude A (%) =100            Amplitude B (%) =100            Step @ T(s) =30.000</p> </div> <div style="border: 1px solid black; border-radius: 15px; padding: 10px;"> <p>AMP STEP Pg4of4            Step @ E(J) = Off            Step @ Pwr(%) = Off            Step @ Ext Sig= Off</p> </div>	<div style="display: flex; flex-direction: column; align-items: center;"> <div style="margin-bottom: 10px;">  </div> <div style="margin-bottom: 10px;">  </div> <div style="margin-bottom: 10px;">  </div> <div style="margin-bottom: 10px;">  </div> <div style="margin-bottom: 10px;">  </div> <div style="margin-bottom: 10px;">  </div> <div style="margin-bottom: 10px;">  </div> </div>

NOTICE	
	<p>You must go to User I/O and assign pin to Ext Signal.</p>

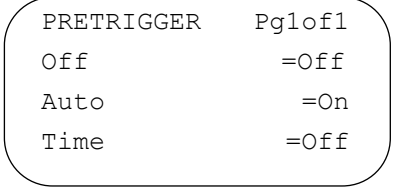
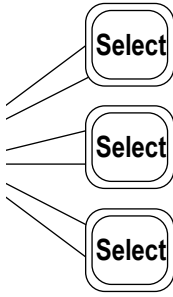
## Setting Pretrigger

You can select whether the ultrasonic energy will be started before the horn makes contact with the part. If you select **ON**, you can set the distance at which the pretrigger ultrasonics will be started, and the amplitude that will be used. Autopretrigger is the default. When Auto Pretrigger is used, ultrasonic energy will start when the horn leaves the home position [1/8 in. (3.175 mm) travel].

**Table 6.14** Setting Pretrigger

Take this action	To get this result	Key
<p>Using the arrow keys, scroll downward through the menu until you see <b>Pretrigger</b>. Press the <b>Select</b> key that corresponds to <b>Pretrigger</b>.</p>	 <pre> WELD SETUP Pg4of15 Amplitude(%) =100 Pretrigger&gt; Off Afterburst&gt; Off                     </pre>	
<p>Press the same <b>Select</b> key again to toggle between Off and On.</p>	 <pre> WELD SETUP Pg4of15 Amplitude(%) =100 Pretrigger&gt; On Afterburst Off                     </pre>	
<p>Press <b>Enter</b> on the numeric keypad to save the new value, or press <b>Go Back/Esc</b> to make no change to the value.</p>		
<p>If you chose Off, continue setting other parameters in the menu.</p>	 <pre> WELD SETUP Pg4of15 Amplitude(%) =100 Pretrigger&gt; Off Afterburst&gt; Off                     </pre>	

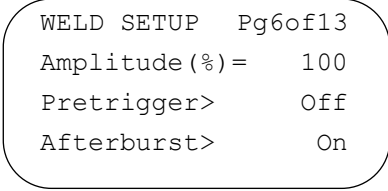
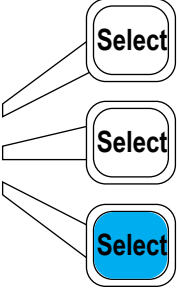
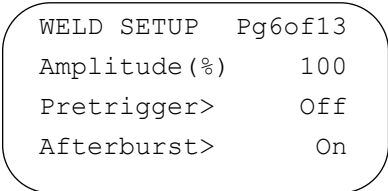
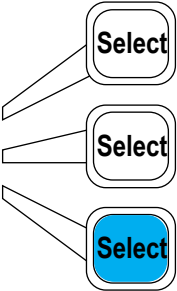
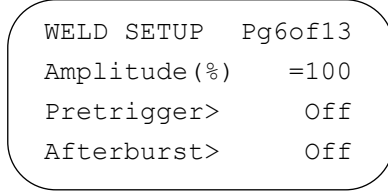
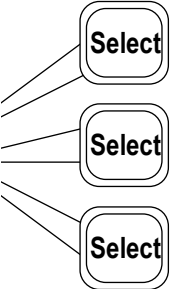
**Table 6.14** Setting Pretrigger

Take this action	To get this result	Key
<p>If you chose On, use the <b>Select</b> keys and the numeric keypad to enter the values you want to use as Pretrigger limits.</p> <p>Use a <b>Select</b> key to choose one of the following ways to begin the pretrigger ultrasonics:</p> <p>Auto starts ultrasonics as the actuator leaves its home position [1/8 in (3.175 mm) minimum], and allows access to enter Pretrg Amp(%) values.</p> <p>Time allows you to select the percentage of maximum amplitude, and Pretrg@T(s) values that will be used for the pretrigger.</p> <p>Press the <b>Go Back/Esc</b> key to exit the submenu.</p>	 <pre> PRETRIGGER  Pg1of1 Off          =Off Auto        =On Time        =Off </pre>	

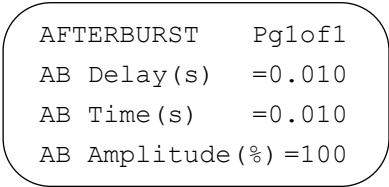
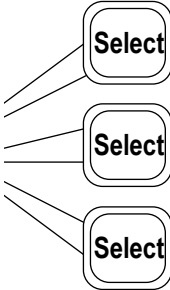
## Setting the Afterburst

You can select whether there will be a burst of ultrasonic energy after welding is complete. If you select **ON**, you can also set the delay and length of the afterburst (in seconds), and the amplitude that will be used.

**Table 6.15** Setting the Afterburst

Take this action	To get this result	Key
<p>Using the arrow keys, scroll downward through the menu until you see <b>Afterburst</b>. Press the <b>Select</b> key that corresponds to <b>Afterburst</b>.</p>	 <pre> WELD SETUP Pg6of13 Amplitude(%)= 100 Pretrigger&gt; Off Afterburst&gt; On                     </pre>	
<p>Press the same <b>Select</b> key again to toggle between On and Off.</p>	 <pre> WELD SETUP Pg6of13 Amplitude(%) 100 Pretrigger&gt; Off Afterburst&gt; On                     </pre>	
<p>Press <b>Enter</b> on the numeric keypad to save the new value, or press <b>Go Back/Esc</b> to make no change to the value.</p>		
<p>If you chose Off, continue setting other parameters in the menu.</p>	 <pre> WELD SETUP Pg6of13 Amplitude(%) =100 Pretrigger&gt; Off Afterburst&gt; Off                     </pre>	

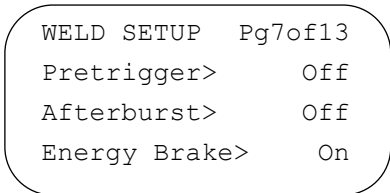
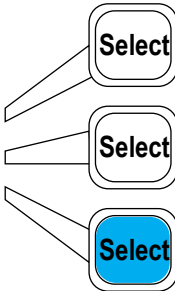
**Table 6.15** Setting the Afterburst

Take this action	To get this result	Key
<p>If you chose On, use the <b>Select</b> keys and the numeric keypad to enter the values you want to use as Afterburst parameters.</p> <p>Use <b>Select</b> keys and the numeric keypad to set the following criteria for the afterburst:</p> <p>AB Delay (s): Set the delay (in seconds) to wait after the end of the hold time until the start of the afterburst. Suggested minimum value is 0.1 second.</p> <p>AB Time (s): Set the Time (in seconds) of the afterburst.</p> <p>AB Amplitude(%): Set the amplitude (as a percentage of the maximum) to be used during the afterburst.</p> <p>Press the <b>Go Back/Esc</b> key to exit the submenu.</p>		

## Energy Brake

Use this menu to turn Energy Braking On or Off. When Energy Brake is turned on, Energy Braking state will be added to the weld sequence after Weld state and before Hold state. This gives the power supply some time to reduce the amplitude before the sonics are shut off. Any overloads that occur will be ignored during this state. They will be handled in the hold state. Weld cycle time will be increased by the time used by Energy Braking.

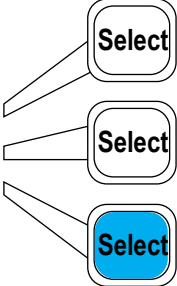
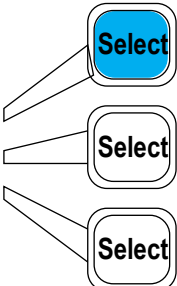
**Table 6.16** Turning Energy Braking on or off

Take this action	To get this result	Key
<p>Using the arrow keys, scroll downward through the menu until you see <b>Energy Brake</b>. Press the <b>Select</b> key that corresponds to <b>Energy Brake</b>. You can toggle between On and Off.</p> <p>When turned On, you use the <math>\pm</math> keys to set a time value between 0.010 and 1.000 second.</p>		

## Digital UPS Setup

Use this menu to setup the DUPS and view available presets.

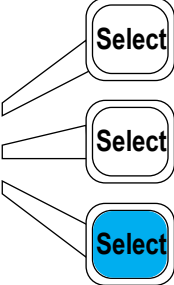
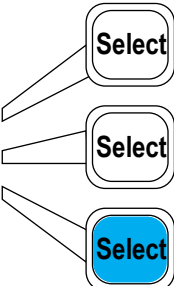

**Table 6.17** Digital UPS setup

Take this action	To get this result	Key
<p>Using the arrow keys, scroll downward through the menu until you see <b>Digital UPS</b>. Press the <b>Select</b> key that corresponds to <b>Digital UPS</b>.</p>	<pre> WELD SETUP Pg7of13 Pretrigger&gt; Off Afterburst&gt; Off Digital UPS&gt;                     </pre>	
<p>This screen is displayed. Press the Select key that corresponds to Setup.</p>	<pre> DIGITAL UPS Pg7of14 Setup&gt; Weld Status = On Preset Names&gt; Memory Reset = On                     </pre>	
<p>The contents of the SETUP screen are displayed (scroll to view Timed Seek). You can toggle to turn Memory or Timed Seek On or Off. Ramp Time can be set from a minimum of .010 to maximum 1.0 seconds, default is .080. Seek Time can be set from a minimum of .100 to maximum 1.00 seconds, default is .500.</p>	<pre> SETUP Pg7of13 Memory = On Ramp Time(s) = 0.080 Seek Time(s) = 0.500 Timed Seek = Off                     </pre>	<p>Press <b>Enter</b> on the numeric keypad to save the new value, or press <b>Go Back/Esc</b> to make no change to the value.</p>

## Setting the Post Weld Seek


You can select Post Weld Seek. Post Weld Seek operates the stack at a low-level (5%) amplitude immediately after the weld cycle afterburst, so the Power Supply can determine the current operating frequency of the stack.

**Table 6.18** Setting the Post Weld Seek

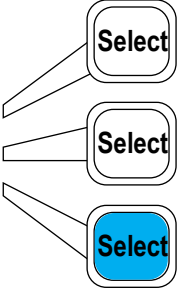
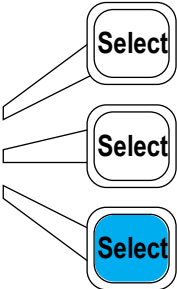

Take this action	To get this result	Key
<p>Using the arrow keys, scroll downward through the menu until you see <b>Post Weld Seek</b>. Press the <b>Select</b> key that corresponds to <b>Post Weld Seek</b>.</p>	<pre>WELD SETUP Pg7of13 Pretrigger&gt; Off Afterburst&gt; Off Post Weld Seek =Off</pre>	
<p>Use the same <b>Select</b> key to toggle between Off and On.</p>	<pre>WELD SETUP Pg7of13 Pretrigger&gt; Off Afterburst&gt; Off Post Weld Seek =On</pre>	
<p>Press <b>Enter</b> on the numeric keypad to save the new value, or press <b>Go Back/Esc</b> to make no change to the value.</p>	<pre>WELD SETUP Pg7of13 Pretrigger&gt; Off Afterburst&gt; Off Post Weld Seek =On</pre>	

## Setting the Frequency Offset

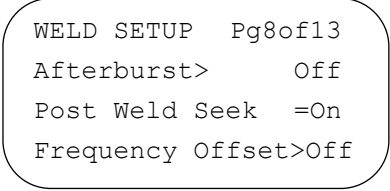
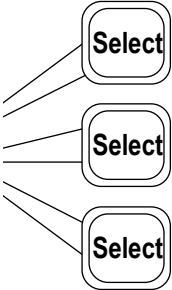
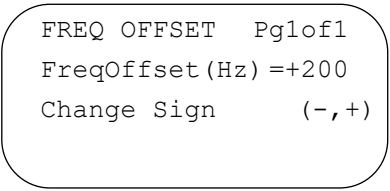
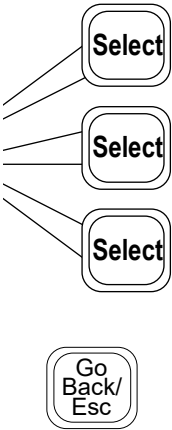
You can select whether to use a Frequency Offset. If you select **ON**, you must also set the offset (in Hz), which the 2000X will apply to the frequency value at the trigger point stored in the Power Supply.

NOTICE	
	<p><b>Do not</b> use this feature unless you are advised to do so by Branson.</p>

**Table 6.19** Setting the Frequency Offset


Take this action	To get this result	Key
<p>Using the arrow keys, scroll downward through the menu until you see <b>Frequency Offset</b>. Press the <b>Select</b> key that corresponds to <b>Frequency Offset</b>.</p>	<pre>WELD SETUP Pg8of13 Afterburst&gt; Off Post Weld Seek =On Frequency Offset&gt;On</pre>	
<p>Press the same <b>Select</b> key again to toggle between On and Off.</p>	<pre>WELD SETUP Pg8of13 Afterburst&gt; Off Post Weld Seek =On Frequency Offset&gt;On</pre>	
<p>Press <b>Enter</b> on the numeric keypad to save the new value, or press <b>Go Back/Esc</b> to make no change to the value.</p>		

**Table 6.19** Setting the Frequency Offset

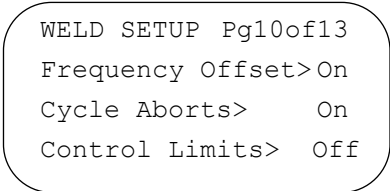
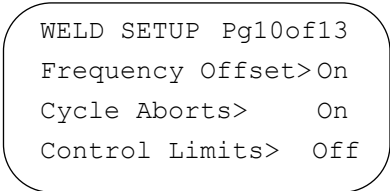
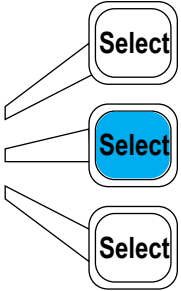
Take this action	To get this result	Key
<p>If you chose Off, continue setting other parameters in the menu.</p>		
<p>If you chose On, press <b>Enter</b>. Use the numeric keypad to enter the frequency offset (Freq Offset) value. or press the <b>Select</b> key repeatedly to toggle between the minimum value and the maximum value for Freq Offset.</p> <p>Selecting <b>Change Sign</b> changes the Freq Offset value from positive to negative. Range of values is <math>\pm 400\text{Hz}</math></p>		

## Setting Cycle Aborts

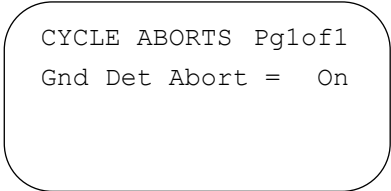
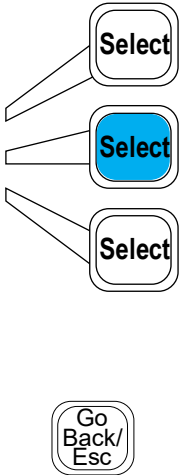
You can select whether to abort any cycle based on certain input conditions. If you select **ON**, you can set the Ground Detect Cutoff to **ON** or **OFF** (to indicate whether to abort the cycle if the horn contacts the electrically isolated fixture or anvil). Any cycle-abort conditions will generate an alarm and terminate the cycle.

NOTICE	
	<p>You must have Ground Detect Cable EDP 100-246-630 installed to utilize Ground Detect Cutoff. It connects at the MPS/GDS located on the rear of the actuator to the isolated fixture/anvil.</p>

**Table 6.20** Setting Cycle Aborts


Take this action	To get this result	Key
<p>Using the arrow keys, scroll downward through the menu until you see <b>Cycle Aborts</b>. Press the <b>Select</b> key that corresponds to <b>Cycle Aborts</b>.</p>	 <pre> WELD SETUP Pg10of13 Frequency Offset&gt;On Cycle Aborts&gt;    On Control Limits&gt;  Off                     </pre>	
<p>Press the same <b>Select</b> key again to toggle between On and Off.</p>	 <pre> WELD SETUP Pg10of13 Frequency Offset&gt;On Cycle Aborts&gt;    On Control Limits&gt;  Off                     </pre>	
<p>Press <b>Enter</b> on the numeric keypad to save the new value, or press <b>Go Back/Esc</b> to make no change to the value.</p>		
<p>If you chose Off, continue setting other parameters in the menu.</p>	 <pre> WELD SETUP Pg10of13 Frequency Offset&gt;On Cycle Aborts&gt;    Off Control Limits&gt;  Off                     </pre>	

**Table 6.20** Setting Cycle Aborts

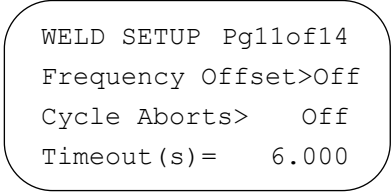
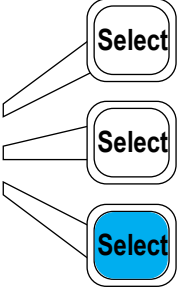
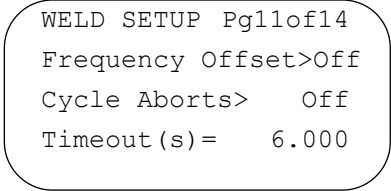
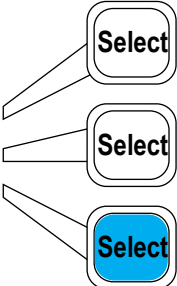

Take this action	To get this result	Key
<p>If you chose On, use the <b>Select</b> keys to set the Ground Detect to On or Off.</p> <p>Press the <b>Go Back/Esc</b> key to exit the submenu.</p>	 <pre>CYCLE ABORTS Pg1of1 Gnd Det Abort = On</pre>	 <p>Three <b>Select</b> keys (one highlighted in blue) and one <b>Go Back/Esc</b> key.</p>

## Setting the Timeout

You select the duration (in seconds) of the maximum allowable time for the primary parameter to be reached during the weld in modes other than time. If the primary parameter has not been reached, the ultrasonic energy will be turned off and the Hold Time will start at the set timeout value.

NOTICE	
	This feature is not available when in time mode.

**Table 6.21** Setting the Timeout

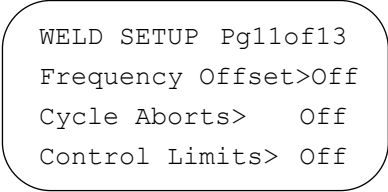
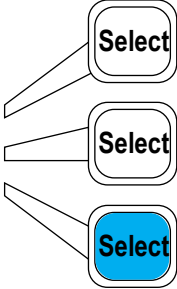
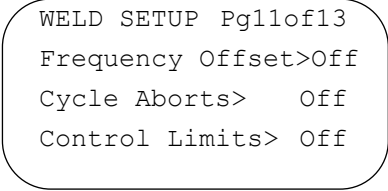
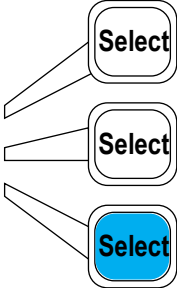

Take this action	To get this result	Key
Using the arrow keys, scroll downward through the menu until you see <b>Timeout</b> . Press the <b>Select</b> key that corresponds to <b>Timeout</b> .		
Use the numeric keypad to enter the timeout, in second(s) that you want to use, or press the same select key again to toggle between the minimum value, 0.050 second(s) and the maximum value, 30.000 second(s) for Timeout.		
Press <b>Enter</b> on the numeric keypad to save the new value, or press <b>Go Back/Esc</b> to make no change to the value.		

## Setting the Control Limits

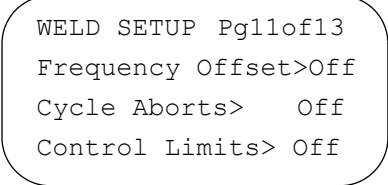
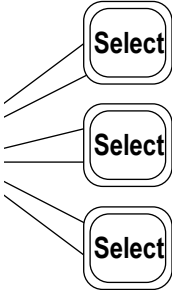
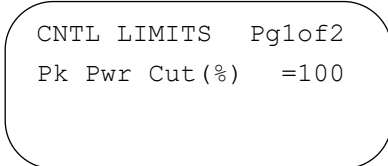
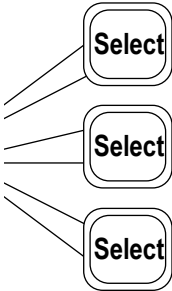
You can select whether to use Control Limits. If you select **ON**, you will set limits of minimum and maximum energy compensation (in Joules), a peak power cutoff (as a percentage of the maximum), an absolute distance (in) measured from the home position, or a collapse distance (in) measured from the trigger. The 2000X uses these Control Limits in addition to the primary weld mode and parameter to determine the end of the welding cycle before moving to the Hold state.

When energy compensation is on and the minimum energy computed value is not reached, the weld time will be extended up to 50% of the Set Weld time value in order to reach this limit. When the maximum energy computed value is reached, the Weld Time will be terminated and the Hold Time will start.

**Table 6.22** Setting the Control Limits

Take this action	To get this result	Key
<p>Using the arrow keys, scroll downward through the menu until you see <b>Control Limits</b>. Press the <b>Select</b> key that corresponds to <b>Control Limits</b>.</p>	 <pre> WELD SETUP Pg11of13 Frequency Offset&gt;Off Cycle Aborts&gt; Off Control Limits&gt; Off           </pre>	
<p>Press the same <b>Select</b> key again to toggle between On and Off to turn the <b>Control Limits</b> Off.</p>	 <pre> WELD SETUP Pg11of13 Frequency Offset&gt;Off Cycle Aborts&gt; Off Control Limits&gt; Off           </pre>	
<p>Press <b>Enter</b> on the numeric keypad to save the new value, or press <b>Go Back/Esc</b> to make no change to the value.</p>		

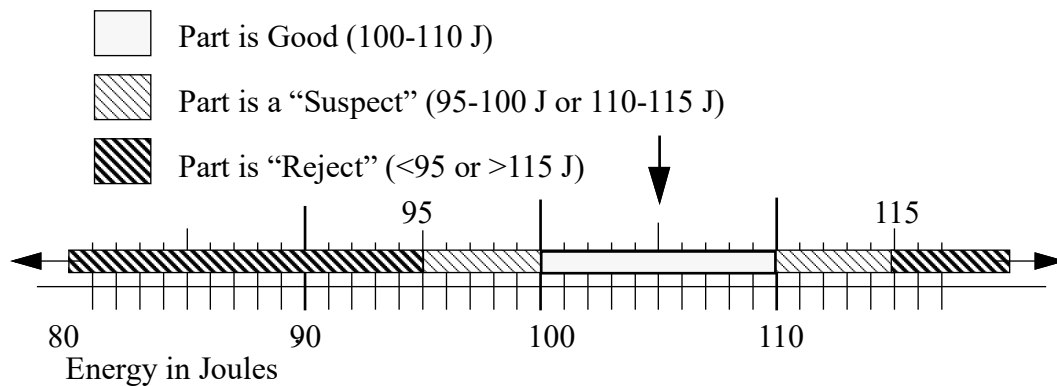
**Table 6.22** Setting the Control Limits

Take this action	To get this result	Key
<p>If you chose Off, continue setting other parameters in the menu.</p>	 <pre> WELD SETUP Pg11of13 Frequency Offset&gt;Off Cycle Aborts&gt; Off Control Limits&gt; Off                     </pre>	
<p>If you chose On, use the <b>Select</b> keys and the numeric keypad to enter the values you want to use as Control Limits.</p> <p>Use the <b>Select</b> keys and the numeric keypad to set the following limits to end the weld portion of the cycle:</p> <p>Pk Pwr Cutoff (%): set the peak power cutoff as a percentage of the maximum peak power.</p> <p>Press the <b>Go Back/Esc</b> key to exit the submenu.</p>	 <pre> CNTL LIMITS Pg1of2 Pk Pwr Cut (%) =100                     </pre>	

## Setting Limits

From within any weld mode, you can set the main parameter (indicated by the name of the weld mode) and Hold Time and several other parameters. The other parameters you can set include Suspect Limits and Reject Limits. You can reduce the amount of scrap from unacceptable parts by identifying those parts that are slightly out of range using Suspect and/or Reject Limits. Upon manual inspection, you might find that these parts are acceptable. You can set the Suspect and Reject Limits on the Power Supply to identify (by counter, or alarm) all parts that fall into limit categories.

For example, consider a weld cycle in Time Weld Mode where you have set the time to 0.280 second. You have determined (by laboratory testing, trial and error, or some other means) that you get an acceptable weld when 100 to 110 Joules of energy have been transmitted to the part. These are the limits that you should then set on the Power Supply as Suspect Limits. You have also determined that the part is a "reject" if it received fewer than 95 Joules or more than 115 Joules. This is illustrated in the following bar graph:



You can set Suspect and Reject Limits for meaningful parameters in each weld mode.

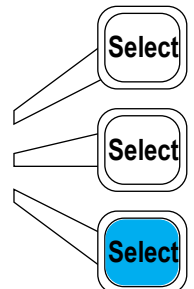
## Setting the Suspect Limits

You can select whether to use Suspect Limits to indicate that a part might not have a good weld. If you select **ON**, you can set limits of minimum and maximum time allowed for the weld, energy levels (in Joules), peak power levels (as a percentage of the maximum), and/or frequency (in Hz). If you set Reset Required to **YES**, when an alarm is generated, you will need to press the **Reset** key prior to welding another part.

**Table 6.23** Setting the Suspect Limits

Using the arrow keys, scroll downward through the menu until you see **Suspect Limits**. Press the **Select** key that corresponds to **Suspect Limits**.

```
WELD SETUP Pg12of13
Cycle Aborts> Off
Control Limits> Off
Suspect Limits> On
```

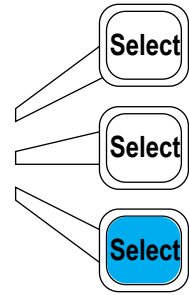


**Table 6.23** Setting the Suspect Limits

Press the same **Select** key again to toggle between On and Off.

```

WELD SETUP Pg12of13
Cycle Aborts> Off
Control Limits> Off
Suspect Limits> On
    
```



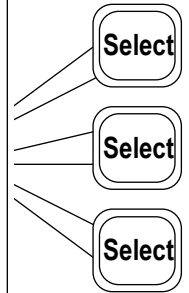
Press **Enter** on the numeric keypad to save the new value, or press **Go Back/Esc** to make no change to the value.



If you chose Off, continue setting other parameters in the menu.

```

WELD SETUP Pg12of14
Cycle Aborts> Off
Control Limits> Off
Suspect Limits> Off
    
```



**Table 6.23** Setting the Suspect Limits

If you chose On, use the **Select** keys and set **Reset Required** to Yes or No.

Use the **Select** keys to set the suspect limits for each of the following categories either with a numeric value or to Off:

-/+Time(s): time (in seconds) above and below the value you chose

-/+Energy(J): energy levels (in Joules) above and below the value you chose to be an acceptable weld.

-/+Pk Power(%): percentages of peak power above and below the value you chose to be an acceptable weld.

Press the **Go Back/Esc** key to exit the submenu.

```
SUSP LIMITS  Pg1of3
Reset Required =Yes
+S Time(s)    =30.000
-S Time (s)   =30.000
```

```
SUSP LIMITSPg2,3,of3
+S Energy (J) =65000
-S Energy (J) =65000
+S Pk Power(%) =100
-S Pk Power(%) = Off
```

Select

Select

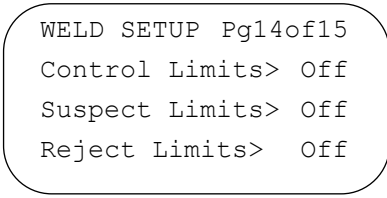
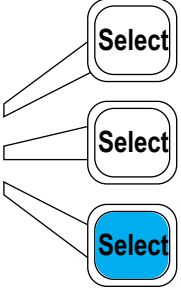
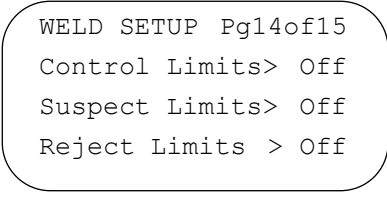
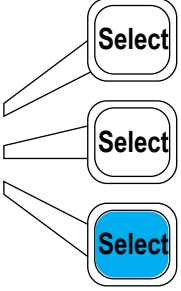

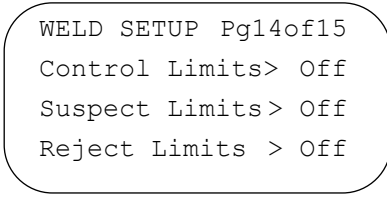
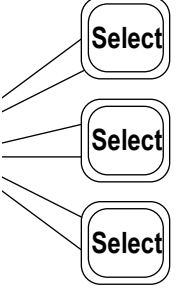
Select

Go  
Back/  
Esc

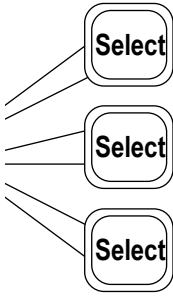

## Setting the Reject Limits

You can select whether to use Reject Limits to indicate that a part does not have a good weld. You can set limits of minimum and maximum time for the weld (in seconds), energy levels (in Joules), peak power levels (as a percentage of the maximum), and/or frequency (in Hz). If you set Reset Required to **YES**, when an alarm is generated, you will need to press the **Reset** key prior to welding another part.

**Table 6.24** Setting the Reject Limits

Take this action	To get this result	Key
<p>Using the arrow keys, scroll downward through the menu until you see <b>Reject Limits</b>. Press the <b>Select</b> key that corresponds to <b>Reject Limits</b>.</p>		
<p>Press the same <b>Select</b> key again to toggle between On and Off.</p>		
<p>Press <b>Enter</b> on the numeric keypad to save the new value, or press <b>Go Back/Esc</b> to make no change to the value.</p>		
<p>If you chose Off, continue setting other parameters in the menu.</p>		

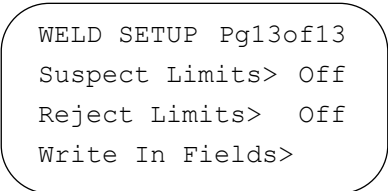
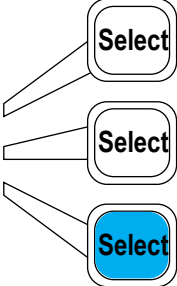
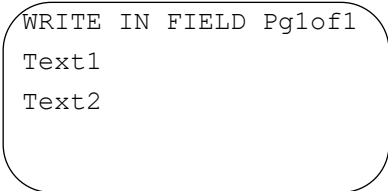
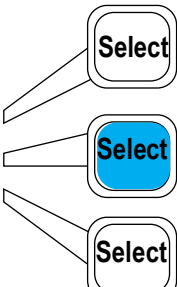
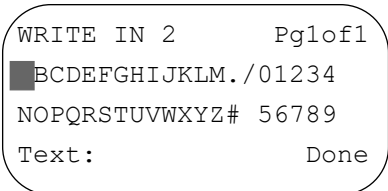
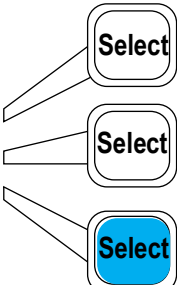
**Table 6.24** Setting the Reject Limits

Take this action	To get this result	Key
<p>If you chose On, use the <b>Select</b> keys and set <b>Reset Required</b> to Yes or No.</p> <p>Use the <b>Select</b> keys to set the suspect limits for each of the following categories either with a numeric value or to Off:</p> <ul style="list-style-type: none"> <li>-/+Time (s): times (in seconds) above and below the value you chose</li> <li>-/+Energy(J): energy levels (in Joules) above and below the value you chose to be an acceptable or suspect weld</li> <li>-/+Pk Power(%): percentages of peak power above and below the value you chose to be an acceptable or suspect weld</li> </ul>	<div style="border: 1px solid black; border-radius: 15px; padding: 5px; margin-bottom: 10px;">             REJ LIMITS Pg1of4              Reset Required =Yes              +R Time (s) =30.000              -R Time (s) =30.000           </div> <div style="border: 1px solid black; border-radius: 15px; padding: 5px; margin-bottom: 10px;">             REJ LIMITS Pg2of4              +R Time (s) =30.000              -R Time (s) =30.000              +R Energy(J) =65000           </div> <div style="border: 1px solid black; border-radius: 15px; padding: 5px;">             REJ LIMITS Pg3and4of4              +R Energy (J) =Off              -R Energy (J) =Off              +R Pk Pwr =Off              -R Pk Pwr =Off           </div>	
<p>Press the <b>Go Back/Esc</b> key to exit the submenu.</p>		

## Write In Fields

Write In Fields allows the assignment of a unique alphanumeric of up to 10 characters to a specific weld setup and cycle that can be viewed on a Host Computer.

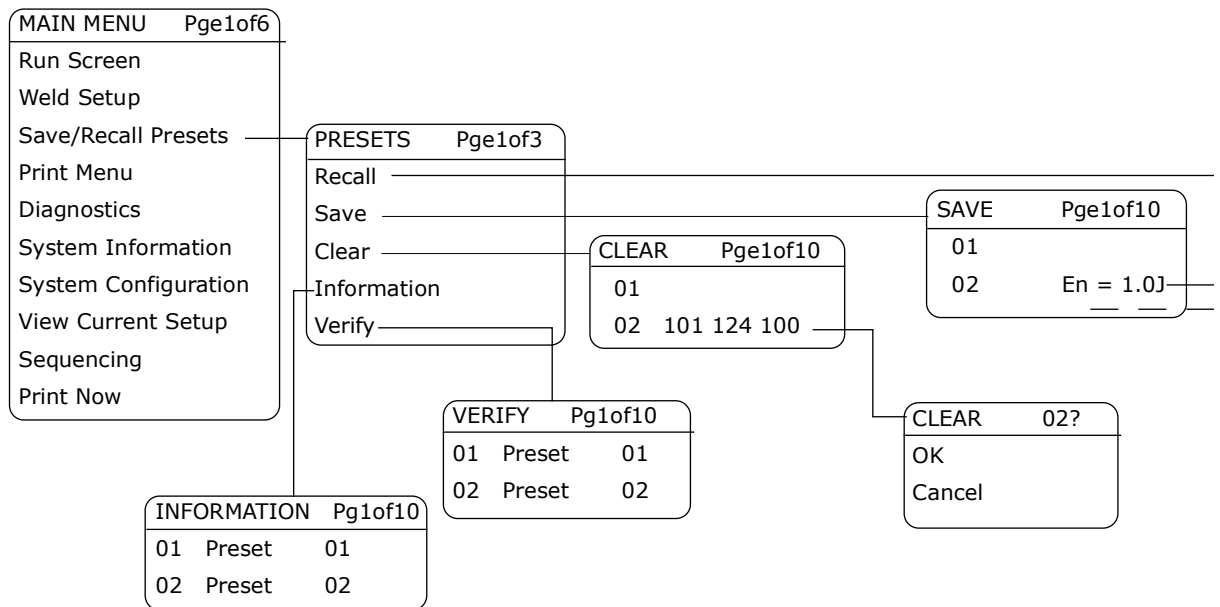
**Table 6.25** Write in Fields

Take this action	To get this result	Key
<p>Using the arrow keys, scroll downward through the menu until you see <b>Write In Fields</b>. Press the <b>Select</b> key that corresponds to <b>Write In Fields</b>. The following screen will appear.</p>	 <pre> WELD SETUP Pg13of13 Suspect Limits&gt; Off Reject Limits&gt; Off Write In Fields&gt;                     </pre>	
<p>Press a <b>Select</b> key to correspond to <b>Text1</b> or <b>Text2</b>. The following screen will appear.</p>	 <pre> WRITE IN FIELD Pg1of1 Text1 Text2                     </pre>	
<p>Use the right arrow to move to and select up to 10 alphanumeric characters by pressing <b>Enter</b> for each text entry. Select <b>Done</b> when finished. This output shows up on the Host Computer.</p>	 <pre> WRITE IN 2 Pg1of1 BCDEFGHIJKLM./01234 NOPQRSTUVWXYZ# 56789 Text: Done                     </pre>	

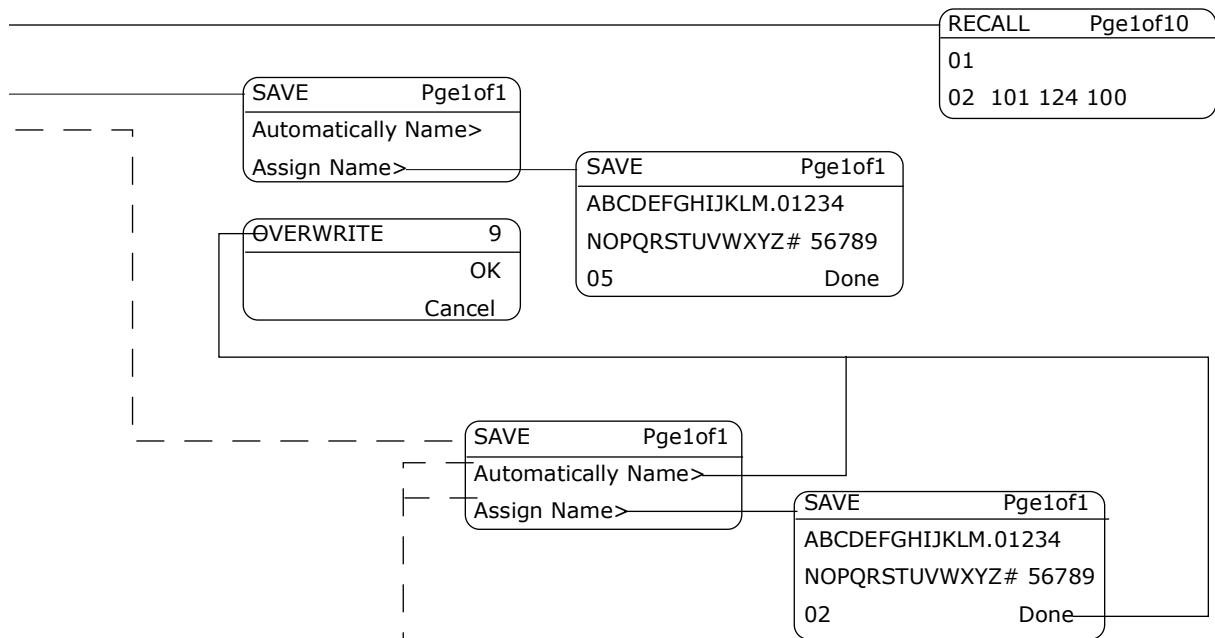
## 6.5 Saving and Recalling Presets

You can set up the 2000X Power Supply to weld a particular application and then save the settings to a preset. You can do this for up to twelve presets.

If, for instance, you have verified through trial and error or some other means that a particular combination of Power Supply settings yields acceptable parts for each of several different configurations or materials, you might want to save that combination of settings as a preset to streamline the change from production of one part to another. Always set the Power Supply to the combination of parameter settings that you want to save before entering the Presets menu. The following two pages contain a map of the menu items available on the Presets menu.



## 2000X energy Power Supply Main Menu: Save/Recall Presets

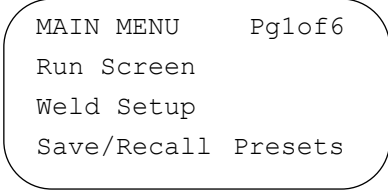

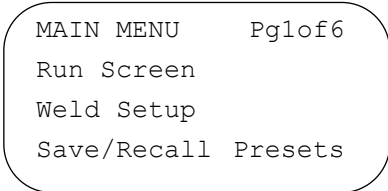
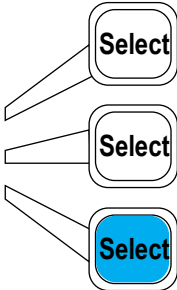
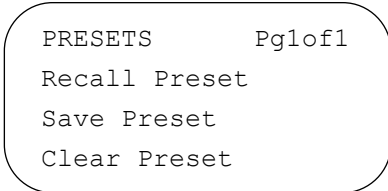
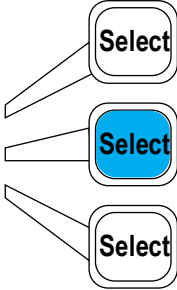


Specific instructions to save presets are detailed in the following screen descriptions.

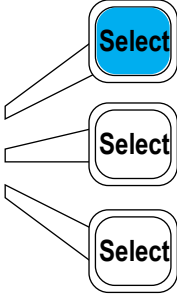
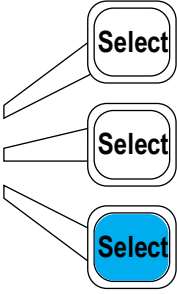
## Saving a Preset

After you have set up the Power Supply to run a weld in a particular way, you can choose to save that combination of settings as a Preset. You will be able to name the Preset to make it easy to recall at a later time.

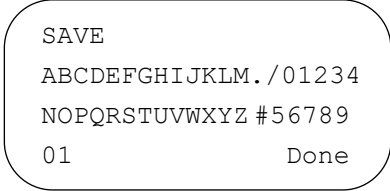
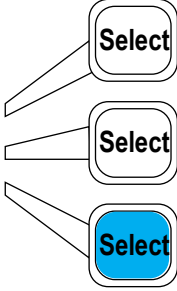
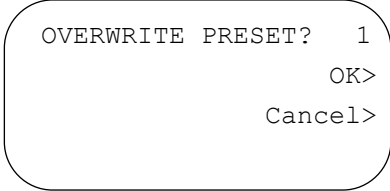
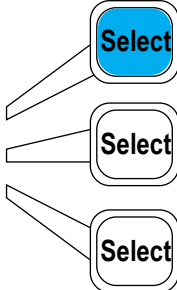
**Table 6.26** Saving a Preset

Take this action	To get this result	Key
<p>Press the <b>Main Menu</b> key.</p>		
<p>Press the <b>Select</b> key that corresponds to <b>Save/Recall Presets</b>.</p>		
<p>Press the <b>Select</b> key that corresponds to <b>Save Preset</b>.</p>		

**Table 6.26** Saving a Preset

Take this action	To get this result	Key
<p>Press the <b>Select</b> key that corresponds to the number of the preset that you want to set.</p>	<pre>SAVE          Pg1of8 01 02 03</pre>	
<p>The Power Supply can name the preset, or you can assign a name.</p>	<pre>SAVE          Pg1of1 Automatically Name&gt; Assign ID Name&gt; Preset 1&gt;</pre>	
<p>To allow the Power Supply to name the preset, after pressing the <b>Select</b> key that corresponds to <b>Automatically Name</b>, you will see the name for the preset appear in the Save Preset list. The convention for naming presets is as follows:</p> <p>Time: Tm = xxxxS</p> <p>Energy: En = xxxxJ</p> <p>Peak Power: PP = xxx%</p> <p>Absolute: Ab = xxx IN</p> <p>Collapse: Cl = xxx IN</p> <p>Ground Detect: GD = xxxS</p> <p>Power Supply will assign same name to all according to mode.</p>	<pre>SAVE          Pg2of10 01 En=1.0J 02 Tm=0.010 03&gt;</pre>	

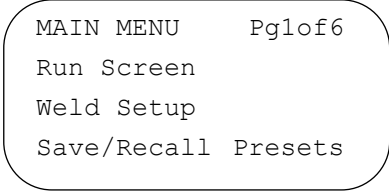

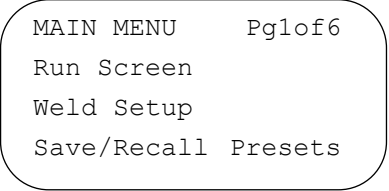
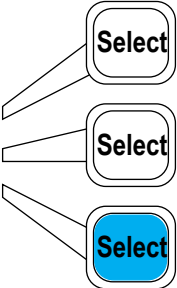
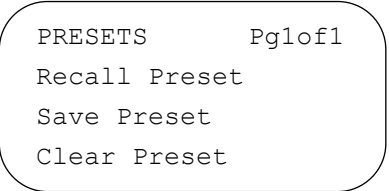
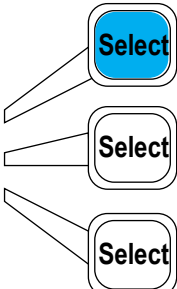
**Table 6.26** Saving a Preset

Take this action	To get this result	Key
<p>To assign a name to a preset, after pressing the <b>Select</b> key that corresponds to <b>Assign ID Name</b>, you will see a submenu where you will assign a name to the preset. To do this, use the arrow keys to scroll to each letter or number you want to select and press <b>Enter</b> on the numeric keypad after each character. Press the <b>Select</b> key that corresponds to <b>Done</b> when you have entered the name you want to use.</p> <p>If you are using a Host Computer, you are limited to only these characters.</p>		
<p>If there is a preset currently in a particular position, you can overwrite the current preset by pressing the <b>Select</b> key that corresponds to <b>OK</b>, or choose not to overwrite the current preset by pressing the <b>Select</b> key that corresponds to <b>Cancel</b>.</p>		

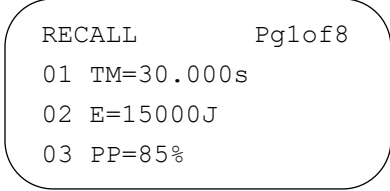
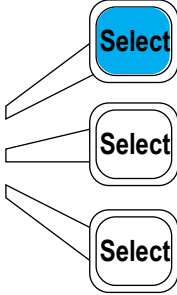
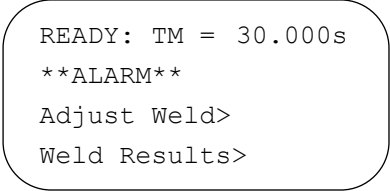
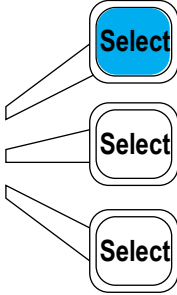
## Recalling a Preset

You can recall a Preset that you had set and named at a previous time to make it easy to begin processing a different type of part.

**Table 6.27** Recalling a Preset

Take this action	To get this result	Key
<p>Press the <b>Main Menu</b> key.</p>		
<p>Press the <b>Select</b> key that corresponds to <b>Save/Recall Presets</b>.</p>		
<p>Press the <b>Select</b> key that corresponds to <b>Recall Preset</b>.</p>		

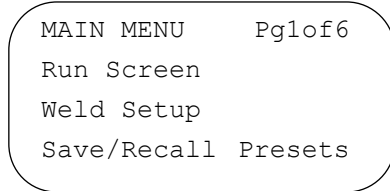

**Table 6.27** Recalling a Preset

Take this action	To get this result	Key
<p>Press the <b>Select</b> key that corresponds to the preset that you want to use.</p>		
<p>The Power Supply will recall all of the parameters you have set to correspond to that preset and return you to the <b>Run Screen</b>. Here you can verify that the correct preset has been recalled Press the select key that corresponds to the alarm message.</p>		

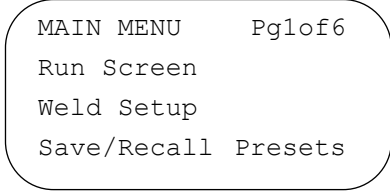
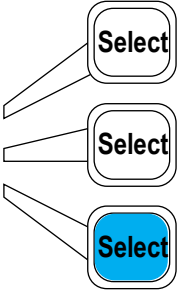
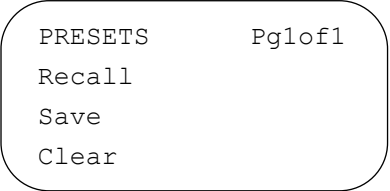
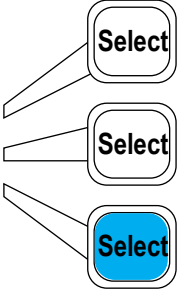
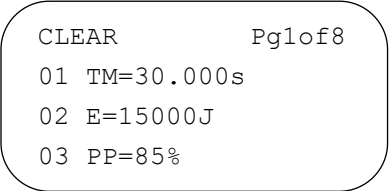
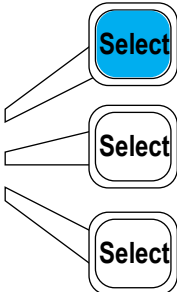
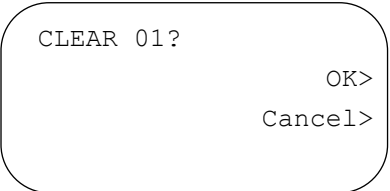
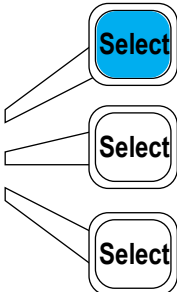
## Clearing a Preset

You can clear a Preset from the memory of your Power Supply. You might want to do this if you have changed the parameters for a given part and have saved them as a new Preset, or if you will no longer be processing a particular type of part.

**Table 6.28** Clearing a Preset

Take this action	To get this result	Key
<p>Press the <b>Main Menu</b> key.</p>		

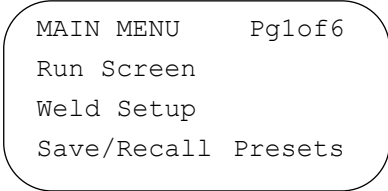

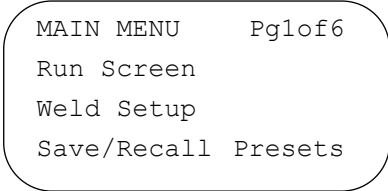
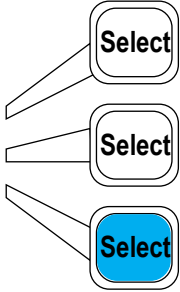
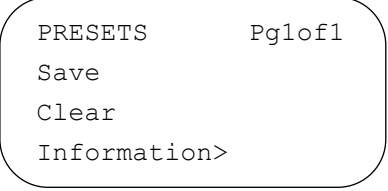
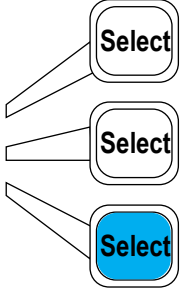
**Table 6.28** Clearing a Preset

Take this action	To get this result	Key
<p>Press the <b>Select</b> key that corresponds to <b>Save/Recall Presets</b>.</p>	 <pre> MAIN MENU      Pg1of6 Run Screen Weld Setup Save/Recall Presets                     </pre>	
<p>Press the <b>Select</b> key that corresponds to <b>Clear Preset</b>.</p>	 <pre> PRESETS        Pg1of1 Recall Save Clear                     </pre>	
<p>Press the <b>Select</b> key that corresponds to the number preset that you want to clear.</p>	 <pre> CLEAR          Pg1of8 01 TM=30.000s 02 E=15000J 03 PP=85%                     </pre>	
<p>To delete the preset, press the <b>Select</b> key that corresponds to <b>OK</b>, or choose not to delete the preset by pressing the <b>Select</b> key that corresponds to <b>Cancel</b> or select the <b>Go Back</b> key.</p>	 <pre> CLEAR 01? OK&gt; Cancel&gt;                     </pre>	

## Preset Information

The Information submenu provides the date and time the preset was last saved. It also shows whether the preset has been verified or not, the preset name and the number of cycles run so far.

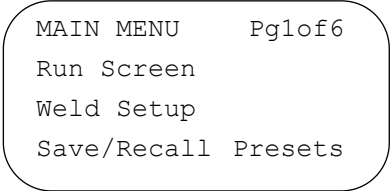

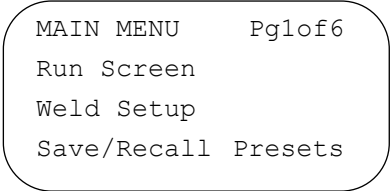
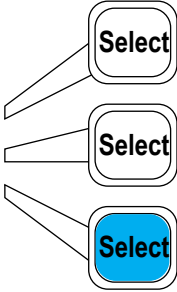
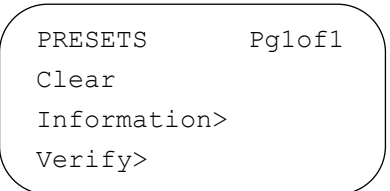
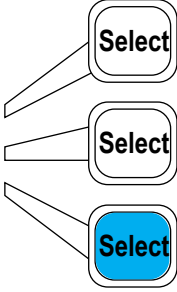
**Table 6.29** Preset Information

Take this action	To get this result	Key
<p>Press the <b>Main Menu</b> key.</p>	 <pre> MAIN MENU      Pg1of6 Run Screen Weld Setup Save/Recall Presets           </pre>	
<p>Press the <b>Select</b> key that corresponds to <b>Save/Recall Presets</b>.</p>	 <pre> MAIN MENU      Pg1of6 Run Screen Weld Setup Save/Recall Presets           </pre>	
<p>Scroll and Press the <b>Select</b> key that corresponds to <b>Information</b>. The screen will then show the 2 presets. Selecting the preset of interest will bring up a screen detailing the information listed at the top of the page.</p>	 <pre> PRESETS        Pg1of1 Save Clear Information&gt;           </pre>	

## Verify Presets

The Verify Preset menu allows preset to be verified instantly without waiting for the next weld cycle. To verify a preset, you first select the preset of interest. After selecting the preset, a pop-up window will display a message for about 2 seconds, declaring whether it is verified or not.

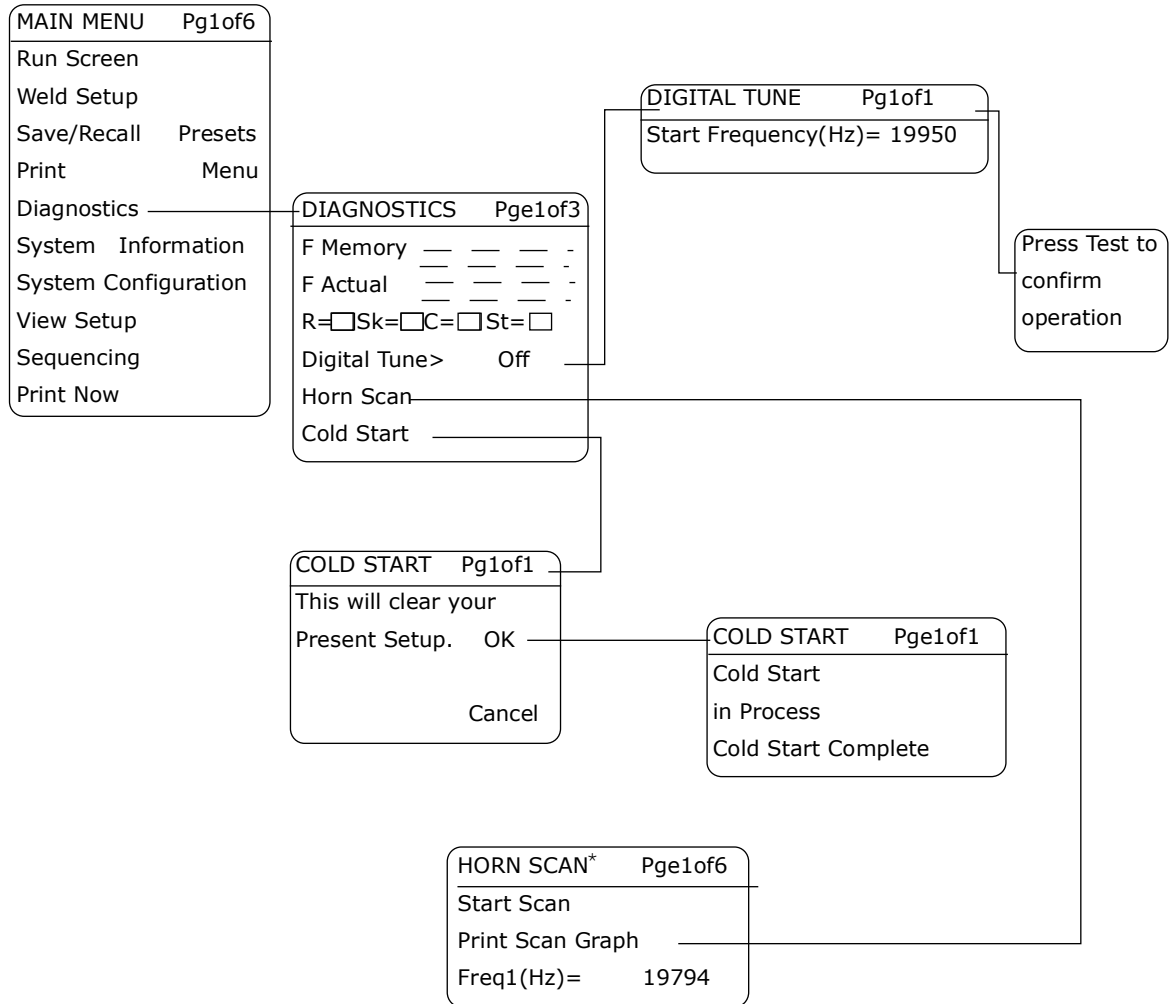
**Table 6.30** Verify Presets

Take this action	To get this result	Key
<p>Press the <b>Main Menu</b> key.</p>		
<p>Press the <b>Select</b> key that corresponds to <b>Save/Recall Presets</b>.</p>		
<p>Scroll and Press the <b>Select</b> key that corresponds to <b>Verify</b>. The screen will then show the 2 presets. Selecting the preset of interest will bring up a message indicating whether the preset is verified or not.</p>		

## 6.6 Using the Diagnostics Menu

You can use the **Diagnostics Menu** to perform a cold start, set the start frequency of your stack, and diagnose your system. The following page contains a map of the menu options available to you on the Diagnostics Menu. For more information on performing a cold start, see [7.6.3 Cold Start Procedures](#). For more information on setting up and testing your system, see [4.11 Testing the Installation](#).

### 2000X ea Power Supply Main Menu: Diagnostics Menu

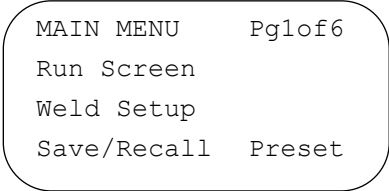

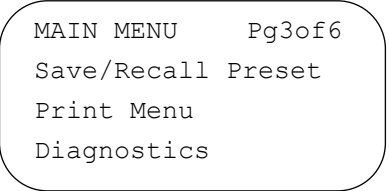
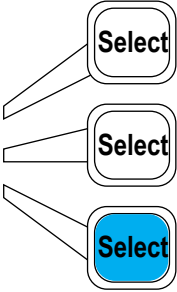


Note: The menu items separated by dotted lines in the menu map appear in series on the Power Supply display.

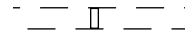
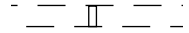
## Viewing Diagnostics

Using the Diagnostics menu, you can view information about the power supply module, change the output frequency of the power supply, and set parameters back to factory default values.

**Table 6.31** Viewing Diagnostics


Take this action	To get this result	Key
<p>Press the <b>Main Menu</b> key.</p>		
<p>Scroll downward through the <b>Main Menu</b> until you see <b>Diagnostics</b>. Press the Select Key that corresponds to <b>Diagnostics</b>.</p>		

**Table 6.31** Viewing Diagnostics

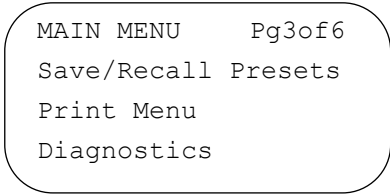
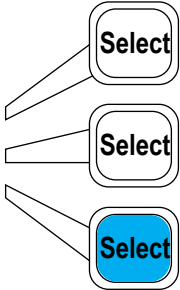
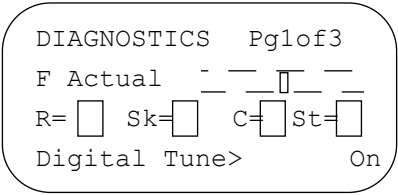
Take this action	To get this result	Key
<p>You can scroll through the Diagnostics menu using the arrow keys. These displays are viewable during a weld cycle.</p> <p><b>F Memory:</b> This bar graph represents the stored frequency at the end of the last cycle. This is the frequency the power supply will start at for the next cycle</p> <p><b>F Actual:</b> This bar graph represents the running (natural) frequency of the stack in real time</p> <p><b>R (Run):</b> Indicates that ultrasonic energy is on</p> <p><b>Sk (Seek):</b> Indicates the power supply is running at 5% amplitude for the purpose of finding the resonant frequency of the stack</p> <p><b>C (Clear):</b> Indicates there was an overload in Run or Test Mode and memory was cleared</p> <p><b>St (Store):</b> Indicates the running frequency of the system is stored into memory at the end of a cycle or at the end of a seek</p>	<div data-bbox="894 401 1289 590" style="border: 1px solid black; border-radius: 15px; padding: 10px; margin-bottom: 20px;"> <p>DIAGNOSTICS Pg1of3</p> <p>F Memory    </p> <p>F Actual    </p> <p>R=<input type="checkbox"/> Sk=<input type="checkbox"/> C=<input type="checkbox"/> St=<input type="checkbox"/></p> </div> <div data-bbox="894 632 1289 821" style="border: 1px solid black; border-radius: 15px; padding: 10px;"> <p>DIAGNOSTICS Pg3of3</p> <p>R=<input type="checkbox"/> Sk=<input type="checkbox"/> C=<input type="checkbox"/> St=<input type="checkbox"/></p> <p>Digital Tune&gt;            Off</p> <p>Horn Scan</p> </div>	

## Setting Digital Tune

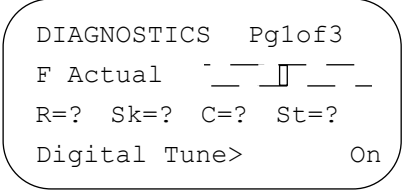
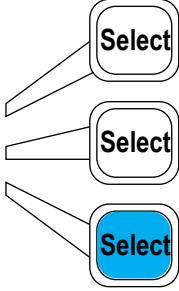
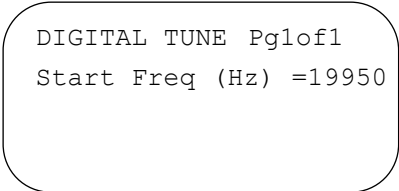

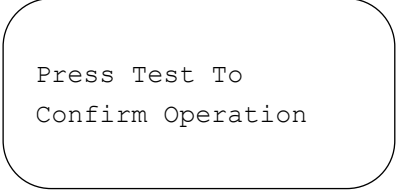

You can select whether to use Digital Tune to change the frequency at which your stack will start. If you select On, you must also set the Frequency (in Hz) at which the 2000X will start ultrasonics.

NOTICE	
	<p>Do not use this feature unless advised to do so by Branson. It is not required for most applications.</p>

**Table 6.32** Setting Digital Tune

Take this action	To get this result	Key
<p>Using the arrow keys, scroll downward through the menu until you see <b>Diagnostics</b>. Press the Select key that corresponds to Diagnostics.</p>		
<p>Using the arrow keys, scroll downward through the menu until you see <b>Digital Tune</b>. Press the Select key that corresponds to Digital Tune.</p>		

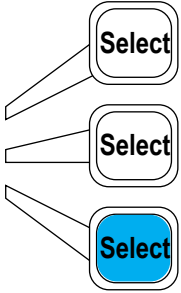
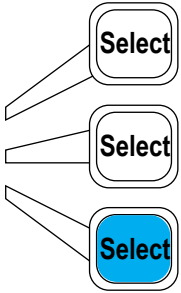
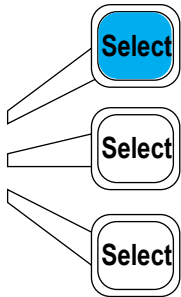
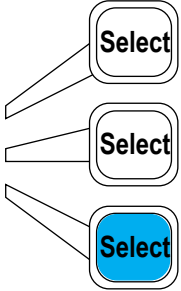
**Table 6.32** Setting Digital Tune

Take this action	To get this result	Key
<p>Press the same Select key again to toggle between On and off.</p>		
<p>Press Enter on the numeric keypad to save the new value, or press Go Back/Esc to make no change to the value.</p>		
<p>Use the numeric keypad to enter the frequency (in Hz) that you want to use then press Enter on the numeric keypad to save the new value.</p>		
<p>Press a menu key or go back to exit the Digital Tune screen. The Display will show "Please wait." After four seconds, the display changes to Press Test to Confirm Operation.</p>		
<p>Press the Test Key to store the new value.</p>		

## Performing a Horn Scan

You can perform a Horn Scan to enhance selection of operating frequency and control parameters. This feature is available in the DUPS only.

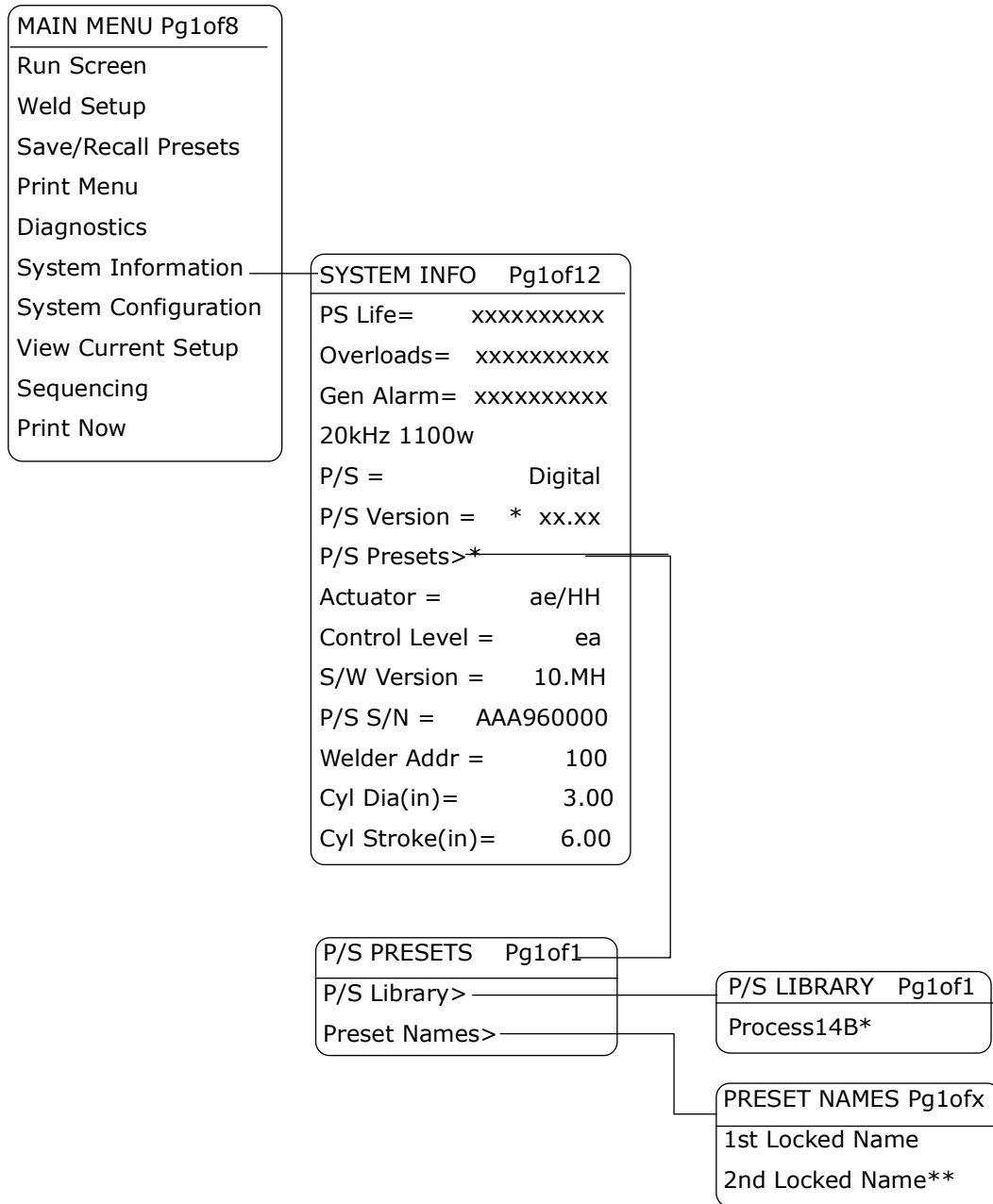
**Table 6.33** Performing a Horn Scan

Take this action	To get this result	Key
<p>Using the arrow keys, scroll downward through the menu until you see <b>Diagnostics</b>. Press the Select key that corresponds to Diagnostics.</p>	<pre> MAIN MENU      Pg3of6 Save/Recall Presets Print Menu Diagnostics           </pre>	
<p>Using the arrow keys, scroll downward through the menu until you see <b>Horn Scan</b>. Press the Select key that corresponds to Horn Scan.</p>	<pre> DIAGNOSTICS   Pg1of3 R=? Sk=? C=? St=? Digital Tune&gt;      On Horn Scan           </pre>	
<p>You will view the <b>Horn Scan</b> submenu. Press the Select Key that corresponds to <b>Start Scan</b>. A scan of horn reactance will be generated showing resonant frequencies at the zero crossover from capacitive to inductive reactance. Ideally there will be only one resonant frequency.</p>	<pre> HORN SCAN     Pg1of6 Start Scan Print Scan Graph Freq1 (Hz) =           </pre>	
<p>Using the arrow keys, scroll downward through the menu to <b>Freq1(Hz)</b>. A frequency will be displayed if a scan was performed. If more than one resonant frequency was found in the scan window, they will be shown by continuing to scroll using the arrow keys. Up to six frequencies can be displayed.</p>	<pre> HORN SCAN     Pg1of6 Start Scan Print Scan Graph Freq1 (Hz) =           </pre>	

## 6.7 Viewing System Information

You can view information from the System Information screen about the current setup of your System. The following page shows a map of the System Information menu.

### 2000X Power Supply Menu Map: System Information



**NOTICE**

This menu reflects Version 10.X software.


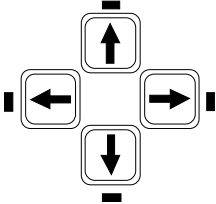
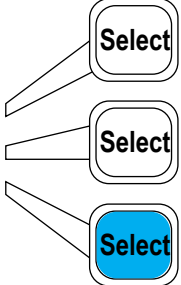
\* 20 character block name

\*\* List can be up to 19 names, but will always contain at least one.

## Viewing System Information

You can view information about your Power Supply using the System Information menu. You should do this before calling Branson for support.

**Table 6.34** Viewing System Information

Take this action	To get this result	Key
<p>Press the <b>Main Menu</b> key.</p>	<pre>MAIN MENU    Pg1of6 Run Screen Weld Setup Save/Recall Presets</pre>	
<p>Scroll downward through the <b>Main Menu</b> until you see <b>System Information</b>.</p>	<pre>MAIN MENU    Pg4of6 Print Menu Diagnostics System Information</pre>	
<p>Press the <b>Select</b> key that corresponds to <b>System Information</b>.</p>	<pre>MAIN MENU    Pg1of6 Print Menu Diagnostics System Information</pre>	
<p>You will see the <b>SYSTEM INFO</b> submenu, where you can scroll through the list of System Information. This is a read-only list. Each parameter is described below:</p>		
<ul style="list-style-type: none"> <li>• PS Life: indicates the total number of cycles on the Power Supply</li> <li>• Overloads: indicates the number of times the Power Supply has been overloaded</li> </ul>	<pre>SYSTEM INFO Pg1of10 Calibration Data&gt; PS Life =      xxxxx Overloads =    xxxxx</pre>	

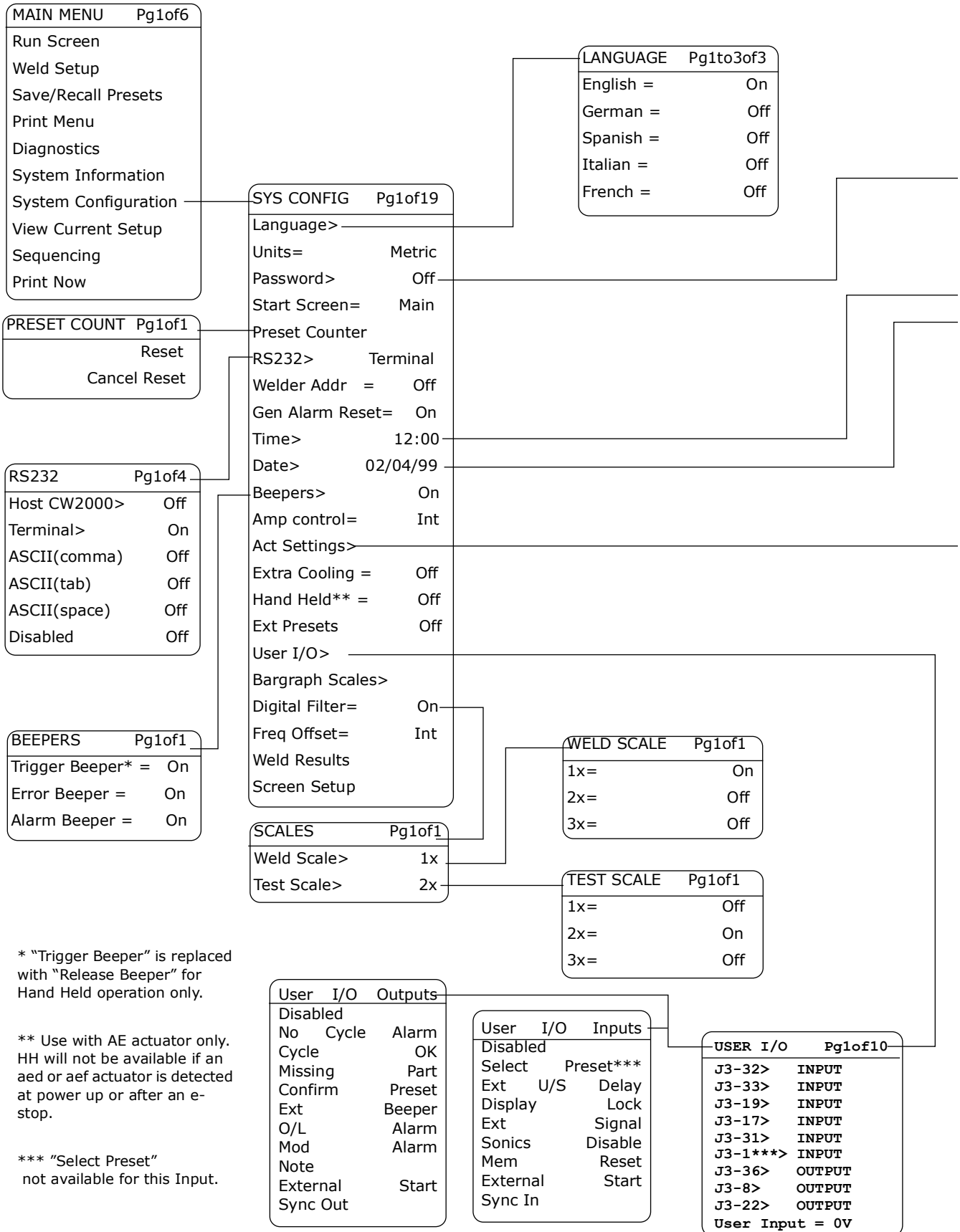
**Table 6.34** Viewing System Information

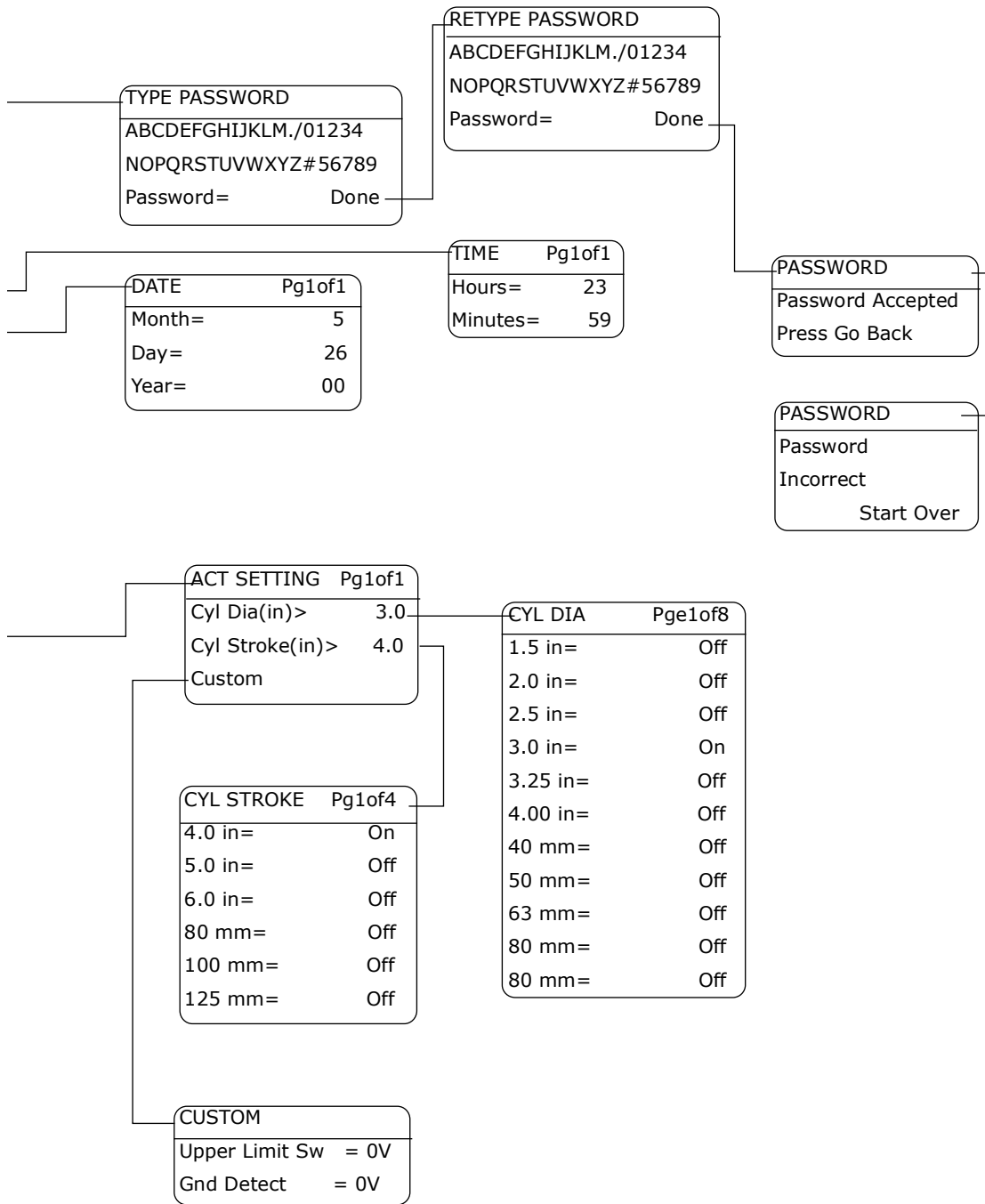
Take this action	To get this result	Key
<ul style="list-style-type: none"> <li>Gen Alarm: indicates the number of times the Power Supply has had general alarms</li> <li>20 kHz 1100 W: this line indicates the frequency and wattage of your Power Supply</li> </ul>	<pre>SYSTEM INFO Pg3of10 Gen Alarm =           0 20kHz 1100W</pre>	
<ul style="list-style-type: none"> <li>P/S Version: indicates digital Power Supply software version. (Currently not shown)</li> <li>P/S Presets: indicates Preset names and library name</li> <li>Actuator: indicates the model actuator that is attached to your Power Supply</li> </ul>	<pre>SYSTEM INFO Pg4of10 P/S Version =   xx.xx P/S Presets Actuator =     ae/HH</pre>	
<ul style="list-style-type: none"> <li>Control Level: indicates the feature level of the controller installed in your Power Supply</li> <li>S/W Version: Indicates the software version</li> <li>P/S S/N: indicates the serial number of the Power Supply</li> </ul>	<pre>SYSTEM INFO Pg7of10 Control Level =   ea S/W Version =   x.xx P/S S/N =       xxxxxx</pre>	
<ul style="list-style-type: none"> <li>Welder Addr: Turn on to assign a unique trackable number to a welder for data collection</li> <li>Cyl Dia (in): indicates the diameter of the cylinder</li> <li>Cyl Stroke (in): indicates the length of the stroke</li> </ul>	<pre>SYSTEM INFO Pg9,10of10 Welder Addr =     100 Cyl Dia (in) =   3.000 Cyl Stroke (in) = 4.0</pre>	

## 6.8 Using the System Configuration Menu

You can use the System Configuration Menu to select the language to be used, set units in which the Power Supply will operate (that is, Metric or USCS), enter a password, reset counters or alarms, set the date or time, turn beeper controls on or off, and perform other system-related changes. The following two pages show a map of the menu choices available to you from the System Configuration menu.

## 2000X Power Supply Menu Map: System Configuration





---

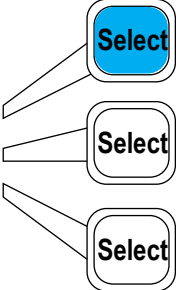
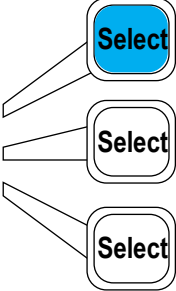
**Each parameter in the System Configuration menu is described below:**

- Language: allows you to select English, German, Spanish, Italian or French language text.  
NOTE: After selecting language, press Enter, then GoBack/Esc
  - Units: allows you to select USCS (English) or Metric units
  - Password: allows you to set a password that limits access to the System Configuration Menu, weld setup or recalling a preset
  - Start Screen: allows you to choose whether to start at the Main menu or Run screen on power up
  - Preset Counter: allows you to reset the running preset counter
  - RS232: allows you to turn the Host Computer operation of the Power Supply on and off. Additionally, weld data is sent out through the serial port after each weld as an ASCII string and can be read by either a PC or PLC
  - Welder Address: identifies welder used for data collection. 4 digit numeric ID, from 1 to 9999
  - Gen Alarm Reset: allows you to set whether a reset is required following a general alarm condition
  - Time: allows you to set the current time, in HH:MM format, on a 24-hour clock
  - Date: allows you to set the current date, in MM/DD/YY format
  - Beeper: allows you to turn the Trigger Beeper, the Error Beeper, and the Alarm Beeper on and off. For Hand Held operation, Trigger Beeper is replaced by Release Beeper. The Release Beeper, if enabled, will sound with a single 500ms pulse when the cycle start signal can be released
  - P/S Settings: allows Power Supply selection, and configuration for the analog supply
  - Amp Control: allows you to set whether amplitude is controlled internally (INT) or externally (EXT)
  - Extra Cooling: when On, allows cooling air to start when upper limit switch is triggered and remain on throughout cycle. When Off, air is applied at ultrasonics application
  - Act Settings: allows you to set the diameter (in inches or millimeters) of your cylinder, and the stroke length in inches or millimeters
  - Hand Held: is turned On or Off. Hand Held will run in Time, Energy, Ground Detect and Peak Power modes except for control level "t". "t" will only run Time and Ground Detect modes
  - Ext Presets: is turned On or Off and can be used in both normal and Hand Held modes
  - User I/O: allows you to define how configurable inputs/outputs are used
  - Bar Graph Scales: allows you to set the weld scale and test scale to 1X, 2X, or 3X
  - Digital Filter: allows you to turn the digital filter for graphing on or off
  - Freq Offset: allows you to set whether the frequency offset is internally (INT) or externally (EXT) controlled
-

## Selecting Language for the Power Supply

You can select English, German, Spanish, Italian or French as your language of choice.

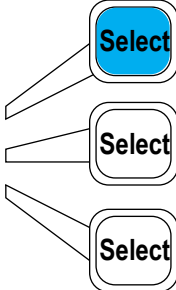
**Table 6.35** Selecting Language for the Power Supply

Take this action	To get this result	Key
Press the <b>Select</b> key that corresponds to <b>Language</b> .	<pre>SYS CONFIG Pg1of19 Language&gt; Units           =USCS Password&gt;      =Off</pre>	
Press the <b>Select</b> key to toggle your language choice to On, and all other choices to Off. Scroll downward to select Italian or French. Press <b>Enter</b> on the numeric keypad to complete selection. You must then press <b>Go Back/Esc</b> key to insure all other keys will function properly in the newly selected language. All subsequent screens will be displayed in the language of choice.	<pre>LANGUAGE Pg1,2,3of3 English=      On German=       Off Spanish=      Off Italian=      Off French=       Off</pre>	

## Selecting Units for the Power Supply

You can choose to use USCS or metric units for measurements in the Power Supply.

**Table 6.36** Selecting Units for the Power Supply

Take this action	To get this result	Key
Press the <b>Select</b> key that corresponds to <b>Units</b> .	<pre>SYS CONFIG Pg1of19 Units           =USCS Password&gt;      =Off Start Screen    =Run</pre>	

**Table 6.36** Selecting Units for the Power Supply

Take this action	To get this result	Key
<p>Press the <b>Select</b> key repeatedly to toggle between USCS and Metric. Press the <b>Enter</b> key on the numeric keypad when you have set <b>Units</b> to the value you want.</p>	<pre>SYS CONFIG Pg1of19 Units          =Metric Password&gt;     =Off Start Screen   =Run</pre>	

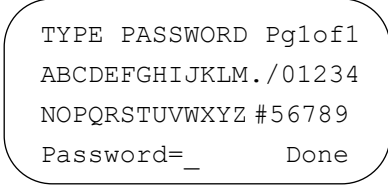
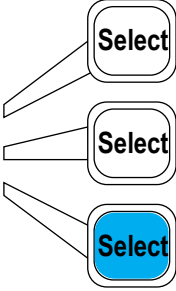
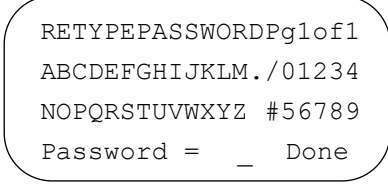
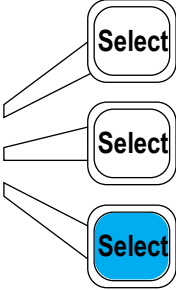
## Setting a Password

You can set a password to protect your settings in the Power Supply.

**Table 6.37** Setting a Password

Take this action	To get this result	Key
<p>Press the <b>Select</b> key that corresponds to <b>Password</b> on the <b>System Config</b> menu.</p>	<pre>SYS CONFIG Pg1of19 Units          =USCS Password&gt;     =Off Start Screen   =Run</pre>	
<p>Press the <b>Select</b> key repeatedly to toggle between Off and On. Press the <b>Enter</b> key on the numeric keypad when you have set <b>Password</b> to the value you want.</p>	<pre>SYS CONFIG Pg2of19 Units          =USCS Password&gt;     =On Start Screen   =Run</pre>	

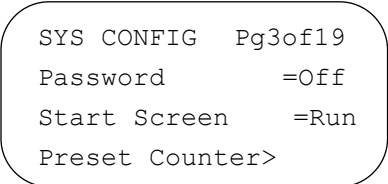
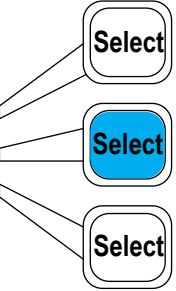
**Table 6.37** Setting a Password

Take this action	To get this result	Key
<p>If you set Password to On &gt; <b>Enter</b>, you will see the <b>TYPE PASSWORD</b> submenu. Use the arrow keys to scroll through the alphanumeric characters shown on the display and select each character of your password by pressing the <b>Enter</b> key on the numeric keypad. You can also select a password by using the numeric keypad. As you select a character, you will see an asterisk displayed next to <b>Password=</b>. When you have entered your entire password, up to six characters, press the <b>Select</b> key that corresponds to <b>Done</b>.</p>	 <pre>TYPE PASSWORD Pg1of1 ABCDEFGHIJKLM./01234 NOPQRSTUVWXYZ #56789 Password=*      Done</pre>	
<p>Retype your password in the same way to confirm. Press the <b>Select</b> key that corresponds to <b>Done</b> when you have finished.</p> <p>You will see a message confirming that your password has been accepted.</p> <p>If your password has not been accepted, you will see a message displayed "Password Incorrect Start Over".</p>	 <pre>RETYPEPASSWORDPg1of1 ABCDEFGHIJKLM./01234 NOPQRSTUVWXYZ #56789 Password = *      Done</pre>	

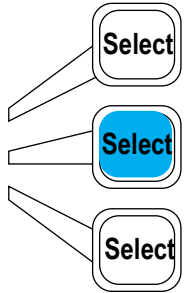
## Selecting a Start Screen

You can choose whether to begin from the Main Menu or the Run screen, when you start up the Power Supply.

**Table 6.38** Selecting a Start Screen

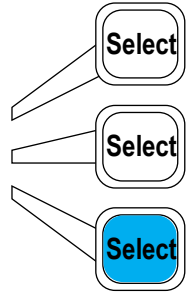
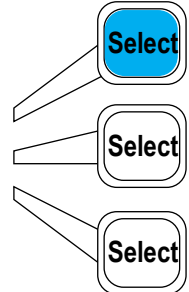
Take this action	To get this result	Key
<p>Press the <b>Select</b> key that corresponds to <b>Start Screen</b>.</p>	 <pre>SYS CONFIG Pg3of19 Password =Off Start Screen =Run Preset Counter&gt;</pre>	

**Table 6.38** Selecting a Start Screen

Take this action	To get this result	Key
<p>Press the <b>Select</b> key repeatedly to toggle between Main and Run. Press the <b>Enter</b> key on the numeric keypad when you have set <b>Start Screen</b> to the value you want.</p>	<pre>SYS CONFIG  Pg3of19 Password      =Off Start Screen  =Run Preset Counter&gt;</pre>	

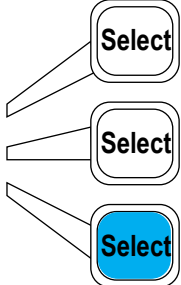
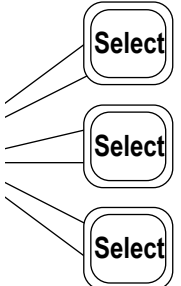
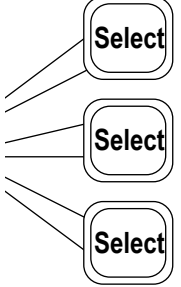
## Resetting the Presets Counter

**Table 6.39** Resetting the Presets Counter

Take this action	To get this result	Key
<p>Press the <b>Select</b> key that corresponds to <b>Preset Counter&gt;</b>.</p>	<pre>SYS CONFIG  Pg4of19 Start Screen  =Run Preset Counter&gt; RS232&gt;      Terminal</pre>	
<p>Press the <b>Select</b> key that corresponds to <b>Reset</b>. The counter for the current preset will be reset.</p>	<pre>PRESET COUNT Pg1of1 Reset Cancel Reset</pre>	

## Setting Parameters for RS232

**Table 6.40** Setting Parameters for RS232

Take this action	To get this result	Key
<p>Press the <b>Select</b> key that corresponds to <b>RS232</b>.</p>	<pre>SYS CONFIG Pg4of19 Start Screen =Main Preset Counter&gt; RS232&gt; Host/CW2000</pre>	
<p>You will see the first page of the <b>RS232</b> submenu. Press the <b>Select</b> key that corresponds to <b>Host Computer, or ASCII(comma)</b>. Selection of any choice will toggle non selections Off. The ASCII(comma) selection generates an ASCII string of weld data out the serial port after each weld. Data is separated in this case by a comma. Other choices are on page 2 of this menu.</p>	<pre>RS232 Pg1of4 Host/CW2000 =Off Terminal =On ASCII (comma) =Off</pre>	
<p>You can choose the other forms of ASCII output from this menu. Data output choice is separated either by a tab or a space. Disabled On will cause all output from the serial port to cease.</p>	<pre>RS232 Pg4of4 ASCII (tab) =Off ASCII (space) =Off Disabled =Off</pre>	

## Data String Sample Output

The following examples illustrate the data string that is sent out through the serial port after each weld. IDID The table following these data strings shows the relationship between control levels. IDID can be any number from 1 to 9999. Table headings 1 through 3 respectively reference data string examples 1 through 3.

1. Sample Output for Control Level t with an ae actuator.

IDID@cccccccc@hh:mm:ss@MM/DD/YY@Mode@tt.ttt@sfff@aaaCRLF

USCS units

IDID@cccccccc@hh:mm:ss@DD/MM/YY@Mode@tt.ttt@sfff@aaaCRLF

Metric units

2. Sample output for Control Level ea, or d with an ae actuator.

IDID@cccccccc@hh:mm:ss@MM/DD/YY@Mode@tt.ttt@ppp.p@eeeeee@sfff@aaa@bbbCRLF

USCS units

IDID@cccccccc@hh:mm:ss@DD/MM/YY@Mode@tt.ttt@ppp.p@eeeeee@sfff@aaa@bbbCRLF

Metric units

3. Sample Output for Control Level d with an aed actuator.

IDID@cccccccc@hh:mm:ss@MM/DD/YY@Mode@tt.ttt@ppp.p@eeeeee@w.www@z.zzzz@

x.xxxx@FFF@hhh@sfff@aaa@bbb@vv.vCRLF

USCS units

IDID@cccccccc@hh:mm:ss@DD/MM/YY@Mode@tt.ttt@ppp.p@eeeeee@ww.www@zz.zzz@

xx.xxx@FFF@hhh@sfff@aaa@bbb@vv.vCRLF

Metric units

**Table 6.41** Code Output

1	2	3	4	Where	Definition
x	x	x	x	cccccccc@	is up to an 8-digit cycle count (Cycle Number)
x	x	x	x	hh:mm:ss@	is time of cycle in hours, minutes and seconds (Time)
x	x	x	x	MM/DD/YY@	is date in month, day and year (Date)
x	x	x	x	Mode@	is weld mode (TIME, ENERGY, PKPWR, COL. ABS, G DET)
x	x	x	x	tt.ttt@	length of ultrasonics in seconds (Act. Time)
	x	x	x	ppp.p@	is the peak power in percentage (Peak Power)
	x	x	x	eeeeee@	is energy in joules (Act. Ener)
		x	x	w.www@	is absolute distance at end of hold in inches or mm (Total Absolute)
		x	x	z.zzzz@	is collapse at end of weld in inches or mm (Weld Collapse)
		x	x	x.xxxx@	is collapse at end of hold in inches or mm (Total Collapse)
		x	x	FFF@	is the trigger force in pounds or Newton's (Trig. Force)

**Table 6.41** Code Output

1	2	3	4	Where	Definition
			x	AAA@	is set weld force or force A in pounds or Newton's (Set Force A)
			x	BBB@	is set force B in pounds or Newton's or N/A (Set Force B)
		x	x	hhh@	is the weld force in pounds or Newton's (Weld Force)
x	x	x	x	sfff@	is frequency change (Hz) from start of ultrasonics to end (Freq. Chg)
x	x	x	x	aaa@	is the set amplitude (or amplitude A) in percentage (Set AmpA)
	x	x	x	bbb@	is the set amplitude B in percentage or N/A (Set AmpB)
		x	x	CRLF	is the Carriage Return, Line Feed
		x	x	vv.v	is the velocity in in/sec or mm/sec (Act. Vel)
x	x	x	x	@	is either a space, tab or comma as selected by user
x	x	x	x	IDID	is a 4 digit # assigned by "welder Addr" in system configuration

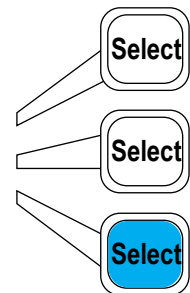
## Using Welder Address

**Table 6.42** Using Welder Address

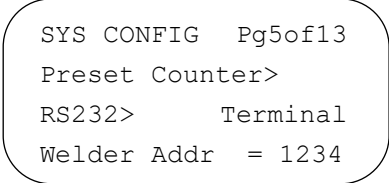
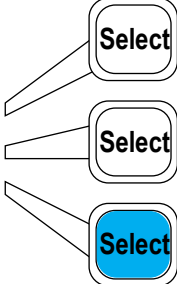
Take this action	To get this result	Key
------------------	--------------------	-----

Press the **Select** key that corresponds to **Welder Addr**. Press **Enter**.

```
SYS CONFIG Pg5of13
Preset Counter>
RS232> Terminal
Welder Addr = Off
```

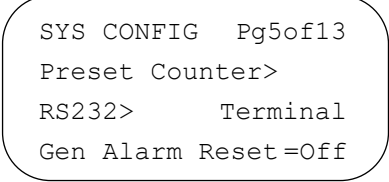
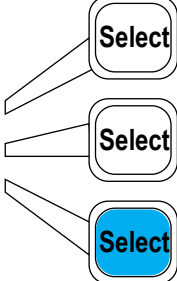


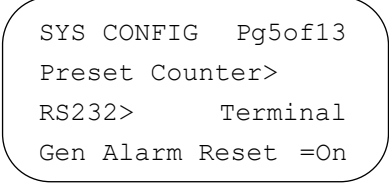
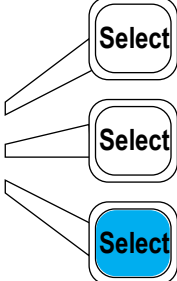
**Table 6.42** Using Welder Address

Take this action	To get this result	Key
<p>Use the numeric keypad to enter the <b>Welder Addr</b> identification number that you want to use, or press the same <b>Select</b> key repeatedly to toggle between the minimum value (1), and the maximum value (9999) for <b>Welder Addr</b> or <b>Off to disable the Welder Addr</b>.</p>	 <pre> SYS CONFIG  Pg5of13 Preset Counter&gt; RS232&gt;      Terminal Welder Addr = 1234                     </pre>	

## Turning the General Alarm Reset On or Off

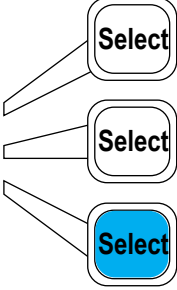
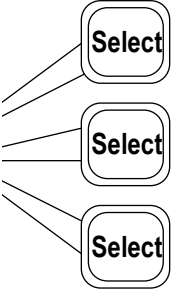
**Table 6.43** Turning the General Alarm Reset On or Off

Take this action	To get this result	Key
<p>Press the <b>Select</b> key that corresponds to <b>Gen Alarm Reset</b>.</p>	 <pre> SYS CONFIG  Pg5of13 Preset Counter&gt; RS232&gt;      Terminal Gen Alarm Reset =Off                     </pre>	

<p>Press the <b>Select</b> key repeatedly to toggle between Off and On. Press the <b>Enter</b> key on the numeric keypad when you have set <b>General Alarm Reset</b> to the function you want.</p>	 <pre> SYS CONFIG  Pg5of13 Preset Counter&gt; RS232&gt;      Terminal Gen Alarm Reset =On                     </pre>	
---	--	---

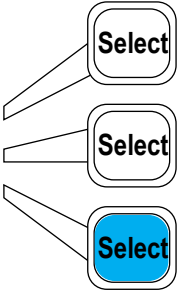
## Setting the System Time

**Table 6.44** Setting the System Time

Take this action	To get this result	Key
<p>Press the <b>Select</b> key that corresponds to <b>Time</b>.</p>	<pre>SYS CONFIG  Pg6of13 RS232&gt;      Terminal Gen Alarm Reset =Off Time&gt;       18:43</pre>	
<p>Press the <b>Select</b> key that corresponds to Hours or Minutes, and use the numeric keypad to set the time, on a 24-hour clock. Press the <b>Go Back/Esc</b> key when you have finished setting the time.</p>	<pre>TIME          Pg1of1 Hours         =18 Minutes      =43</pre>	

## Setting the System Date

**Table 6.45** Setting the System Date

Take this action	To get this result	Key
<p>Press the <b>Select</b> key that corresponds to <b>Date</b>.</p>	<pre>SYS CONFIG  Pg7of13 Gen Alarm Reset =No Time&gt;       18:43 Date&gt;       10/25/00</pre>	

**Table 6.45** Setting the System Date

Take this action	To get this result	Key
<p>Press the <b>Select</b> key that corresponds to Month, Day, or Year, and use the numeric keypad to set the date. Press the <b>Go Back/Esc</b> key when you have finished setting the date.</p>	<pre>DATE          Pg1of1 Month         =10 Day           =25 Year          =98</pre>	

## Turning Beepers On or Off

**Table 6.46** Turning Beeper On or Off

Take this action	To get this result	Key
<p>Press the <b>Select</b> key that corresponds to <b>Beepers</b>.</p>	<pre>SYS CONFIG   Pg8of13 Time&gt;        =18:43 Date&gt;        09/15/98 Beepers&gt;</pre>	

You will see the **Beepers** submenu.

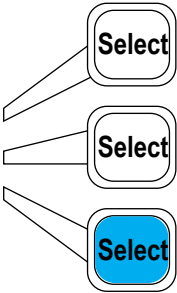
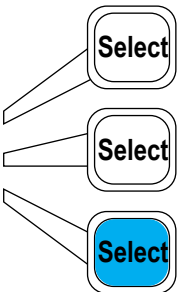
For each type of beeper, Trigger, Error, and Alarm, press the corresponding **Select** key repeatedly to toggle between On and Off. Press the **Enter** key on the numeric keypad when you have set **Beepers** to the state you want. Press the Go Back/Esc key when you have finished setting the beepers.

<pre>BEEPERS      Pg1of1 Trigger Beeper =On Error Beeper  =On Alarm Beeper  =On</pre>	
---	--

## Setting the Amplitude Control

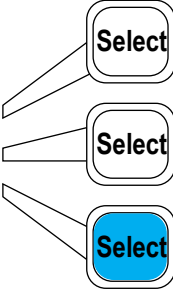
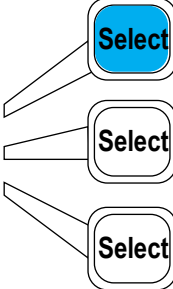
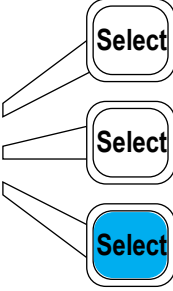
If you set the Amplitude Control to External, you must connect an external voltage-scaling device to the I/O connector. If nothing is connected, only 50% amplitude will be reached.

**Table 6.47** Setting the Amplitude Control

Take this action	To get this result	Key
<p>Press the <b>Select</b> key that corresponds to <b>Amp Control</b>.</p>	<pre data-bbox="802 541 1187 730">SYS CONFIG Pg11of19 Beepers&gt; P/S Settings&gt; Amp Control =Int</pre>	
<p>Press the <b>Select</b> key repeatedly to toggle between Int and Ext. Press the <b>Enter</b> key on the numeric keypad when you have set <b>Amp Control</b> to the state you want.</p>	<pre data-bbox="802 955 1187 1144">SYSCONFIG Pg11of19 Beepers&gt; P/S Settings&gt; Amp Control =Ext</pre>	

## Setting the Cylinder Diameter

**Table 6.48** Setting the Cylinder Diameter

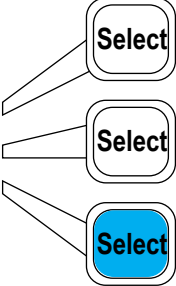
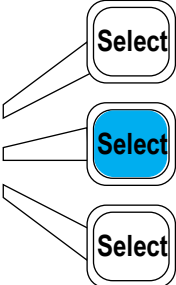
Take this action	To get this result	Key
<p>From the <b>System Configuration</b> menu, press the <b>Select</b> key that corresponds to <b>Act Settings</b>.</p>	<pre>SYS CONFIG Pg12of19 Beepers&gt; Amp Control =Int Act Settings&gt;</pre>	
<p>You will see the <b>ACT SETTING</b> submenu. Press the <b>Select</b> key that corresponds to <b>Cyl Dia</b>.</p>	<pre>ACT SETTING Pg1of1 Cyl Dia (in)&gt; 1.5 Cyl Stroke (in)&gt;4.0 Custom&gt;</pre>	
<p>Press the <b>Select</b> key that corresponds to the cylinder size you are using. Press the <b>Enter</b> key on the numeric keypad when you have selected the size.</p>	<pre>CYL DIA Pg1of8 1.5 in =On 2.0 in =Off 2.5 in =Off</pre>	
	<pre>CYL DIA Pg4of8 3.0 (in) =Off 3.25 (in) =Off 4.0 (in) =Off</pre>	

**Table 6.48** Setting the Cylinder Diameter

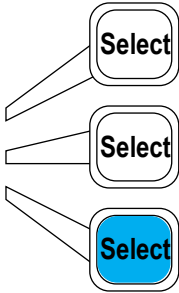
Take this action	To get this result	Key
	<pre> CYL DIA      Pg7of8 40 (mm)      =Off 50 (mm)      =Off 63 (mm)      =Off           </pre>	
	<pre> CYL DIA      Pg8of8 80 (mm)      =Off           </pre>	

## Setting the Cylinder Stroke

**Table 6.49** Setting the Cylinder Stroke

Take this action	To get this result	Key
<p>From the <b>System Configuration</b> menu, press the <b>Select</b> key that corresponds to <b>Act Settings</b>.</p>	<pre> SYS CONFIG Pg10of13 Beepers&gt; Amp Control      =Int Act Settings&gt;           </pre>	
<p>You will see the <b>ACT SETTING</b> submenu. Press the <b>Select</b> key that corresponds to <b>Cyl Stroke</b>.</p>	<pre> ACT SETTING Pg1of1 Cyl Dia (in)&gt;  1.5 Cyl Stroke (in)&gt;4.0           </pre>	

**Table 6.49** Setting the Cylinder Stroke

Take this action	To get this result	Key
<p>Press the <b>Select</b> key that corresponds to the stroke length you are using. Press the <b>Enter</b> key on the numeric keypad when you have selected the length.</p>	<div data-bbox="883 373 1268 558" style="border: 1px solid black; border-radius: 15px; padding: 5px; margin-bottom: 10px;"> <p>CYL STROKE Pg1of4            4.0 in =On            5.0 in =Off            6.0 in =Off</p> </div> <div data-bbox="883 617 1268 802" style="border: 1px solid black; border-radius: 15px; padding: 5px;"> <p>CYL STROKE Pg4of4            80 (mm) =Off            100 (mm) =Off            125 (mm) =Off</p> </div>	

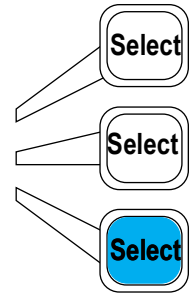
## Custom Actuator Settings

Use these settings to reconfigure standard I/O to use 0V or 24V levels, reassigning user I/O functions.

**Table 6.50** Custom Actuator Settings

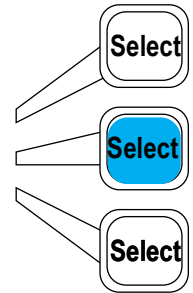
You will see the **ACT SETTING** submenu. Press the **Select** key that corresponds to **Custom**.

```
ACT SETTING Pg1of1
Cyl Dia (in)> 1.5
Cyl Stroke (in)>4.0
Custom>
```



Selecting Custom will display this screen where you can choose to set either Gnd Detect or Upper Limit Sw to 0V or 24V.

```
Custom Pg1of1
Upper Limit Sw = 0V
Gnd Detect = 24V
```



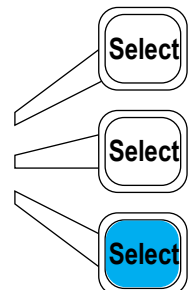
## Setting Extra Cooling

**Table 6.51** Setting Extra Cooling

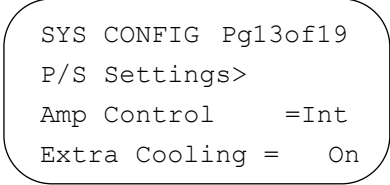
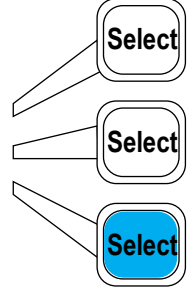
Take this action	To get this result	Key
------------------	--------------------	-----

From the **System Configuration** menu, press the **Select** key that corresponds to **Extra Cooling**. This will toggle the function On and Off. With the cooling Off, cooling air will not be applied until ultrasonics is applied

```
SYS CONFIG Pg13of19
P/S Settings>
Amp Control =Int
Extra Cooling = Off
```



**Table 6.51** Setting Extra Cooling


Take this action	To get this result	Key
<p>When you are configured for 30 kHz operation, <b>Extra Cooling</b> will default to On. The cooling air will then be triggered <b>On</b> from the Upper Limit switch, and remain on through the entire cycle. You can override 30 kHz operation by turning this to Off.</p>	 <pre> SYS CONFIG Pg13of19 P/S Settings&gt; Amp Control    =Int Extra Cooling =  On                     </pre>	

## Hand Held

Hand Held is accessed and turned On or Off in the System Configuration menu. Hand Held will run in Time, Energy, Ground Detect and Peak Power modes.

Hand Held start function can be used with a hand held unit or a "Stack" system without an actuator. The start switch must be maintained until hold time is finished.

No start cable is required as only the RF and user I/O cables are used with an e-stop jumper plug (EDP No. 100-246-1178).

NOTICE	
	<p>Once Hand Held is turned on, the power supply must be powered off and then back on. This prevents the Door/Trigger alarm from occurring.</p>

The Hand Held cycle starts with a single start switch input. Either start switch is usable. The start switch must be maintained until the end of the cycle. The weld cycle includes weld time, hold time, afterburst if enabled and post weld seek if enabled. A beeper signals the end of the need for the start switches to be on.

A single start switch is an optional start condition and is only used when the normal PB or start input is not used. However, if used the Ext Signal must be turned on in systems configuration, User I/O Inputs, and the assigned pin hard wired.


The following Table defines failures and associated alarms when start signal is lost.


**Table 6.52** Alarms and their causes

Alarm	Cause of Alarm
Trigger Lost in Weld	Start signal lost before ultrasonics ends
Trigger Lost in Hold	Start signal lost before Hold ends


**Table 6.52** Alarms and their causes

Alarm	Cause of Alarm
No alarm, cycle stops abruptly, terminates Afterburst	Start signal lost during Afterburst
No alarm, cycle stops abruptly, terminates Post Weld Seek	Start signal lost during Post Weld Seek

NOTICE	
	The Trigger Lost in Weld, or Trigger Lost in Hold alarms will result in an aborted cycle but the weld cycle counter will still be incremented.

NOTICE	
	If the trigger is lost during Afterburst or Post Weld Seek, no alarm will result, but the balance of the cycle will still be aborted and counted.

- Afterburst and Post Weld Seek are available, but the start switch must be maintained through either of them
- Although Pretrigger is shown in the menu, is not functional
- All cutoffs and limits for an AE actuator are available, limited only by the control level of your power supply
- Factory default for Hand Held is off. Cold start will not affect the setting
- The Start Switch Closed alarm has been extended to 6 seconds for all modes
- The PB Released output should be used to signal the PLC to release the start

NOTICE	
	Use with AE actuator only. HH will not be available if an aed actuator is detected at power up or after an e-stop.

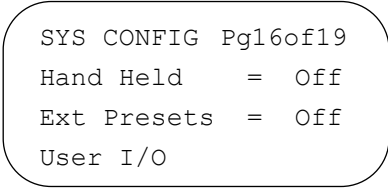
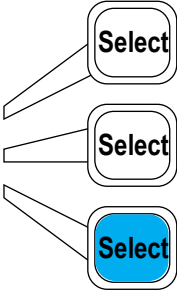
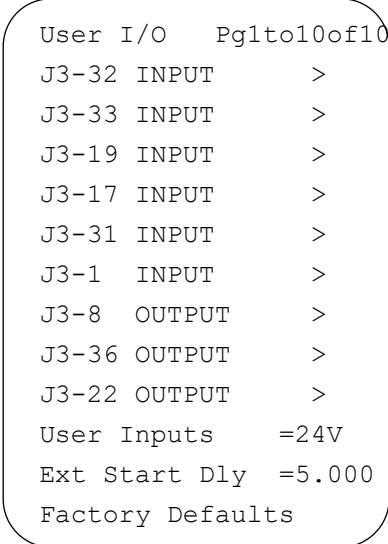
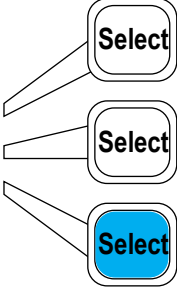
## Ext Presets

Toggle Ext Presets On and Off, >Enter choice.

## Configuring the User I/O

User I/O Menu is used to configure custom actuator inputs and outputs. The User I/O menu can only be entered when the welder is not in the process of welding. If the welder is welding, the beeper will sound and entry will be denied. When entry does occur, the welder will no longer be ready, preventing welding, horn down and test. If horn down is not available, a 2-second message will be displayed indicating horn down is not available.

**Table 6.53** Configuring the User I/O

Take this action	To get this result	Key
<p>From the <b>System Configuration</b> menu, scroll down to <b>User I/O</b> and press the <b>Select</b> key that corresponds to <b>User I/O</b>. This will toggle the function On and Off. The following screen shows a portion of the configurable Input and Output pins that are accessible at J3 when toggled to On.</p>	 <pre> SYS CONFIG Pg16of19 Hand Held      = Off Ext Presets    = Off User I/O                     </pre>	
<p>This screen shows the 6 configurable INPUTs and 3 configurable OUTPUTs. The tables below list the features that can be accessed and selected for each of the INPUT and OUTPUT pins respectively at J3. Please note the pin J3-1 Input exception.</p> <p>User Inputs: toggle to change from 0 to 24V.</p> <p>Ext Start Delay: use keypad to enter value, &gt;Enter.</p> <p>Factory Defaults: Select OK to revert back to factory defaults. Option is Cancel.</p>	 <pre> User I/O Pg1to10of10 J3-32 INPUT      &gt; J3-33 INPUT      &gt; J3-19 INPUT      &gt; J3-17 INPUT      &gt; J3-31 INPUT      &gt; J3-1  INPUT      &gt; J3-8  OUTPUT     &gt; J3-36 OUTPUT     &gt; J3-22 OUTPUT     &gt; User Inputs      =24V Ext Start Dly    =5.000 Factory Defaults                     </pre>	

Refer to the Branson Automation Guide (EDP 100-214-273) for additional information about selection and use of Input and Output features listed in the following Table.

User I/O Inputs	User I/O Outputs
Disabled	Disabled
Select Preset *	No Cycle Alarm
Ext Trg Delay	Cycle OK
Display Lock	Missing Part
Ext Signal	Confirm Preset
Sonics Disable	Amplitude Delay
Mem Reset	Ext Beeper
SV Interlock	O/L Alarm
Sync In	Modified Alarm
	Note
	SV Interlock
	Sync Out

\*This option is not available at J3-1 Input.

## User Definable I/O

This feature allows the user to select from a list of features, and assign the feature to their choice of input or output pin on the I/O connector J3. The User Definable I/Os can be disabled.

There are 8 available features for the 6 available J3 inputs. These features are described in the following Table.

**Table 6.54** Features for User I/O Inputs

Feature No.	Feature Name	Feature Description
1	Select Preset	Select up to 16 presets from 5 of the inputs (J3-1 input does not have this feature)
2	Display Lock	When User I/O Input Display Lock is turned on, the front panel display cannot access any means of changing the current display.
3	External Signal	This input is used to enable Amplitude or Force stepping, and in Hand Held mode for starting sonics.
4	External U/S Delay	Delays starting of ultrasonics up to 30 seconds after trigger conditions are met.
5	Sonics Disable	This is a form of Dry Cycle. It allows running a preset as defined, but not turning on ultrasonics.
6	Memory Reset	Center power supply when input is active, used for sequencing.


**Table 6.54** Features for User I/O Inputs

Feature No.	Feature Name	Feature Description
7	External Start	Allows power supply to close safety door, then start weld cycle. Start signal would activate this External Start output. When the External Start input becomes active then the SV is activated. Must be used with External Start input.
8	Sync In	Works in conjunction with Sync Out to Allow several welders to work together and start sonics on all welders at the same time after all have triggered.

There are 10 available features for the 3 available J3 outputs. These are described in the following Table.

**Table 6.55** Features for User I/O Outputs

Feature No.	Feature Name	Feature Description
1	External Beeper	Echoes the same signal that goes to the internal beeper.
2	Cycle OK	Means a complete cycle was run and there were no alarms.
3	Confirm Preset	An external preset change request has been honored.
4	No Cycle Alarm	Active when a No Cycle alarm occurs. It is cleared by the next cycle or a reset.
5	Overload Alarm	Active whenever an overload alarm occurs. It is cleared by the next cycle or a reset.
6	Modified Alarm	Active whenever a modified cycle alarm occurs, i.e. peak power cutoff. It is cleared by the next cycle or a reset.
7	Note	Active whenever a Note (warning) occurs. It is cleared by the next cycle or a reset.
8	Missing Part	Active whenever the missing part alarm occurs. It is cleared by the next cycle or a reset.
9	External Start	Allows power supply to close clamp, then start weld cycle. Start signal would activate this External Start output. When the External Start input becomes active, then the SV is activated. Must be used with External Start input.
10	Sync Out	Works in conjunction with Sync In allowing several welders to work together and start sonics on all welders at the same time after all have triggered.

NOTICE	
	For additional information about how to use these features, refer to the Branson Automation Guide.

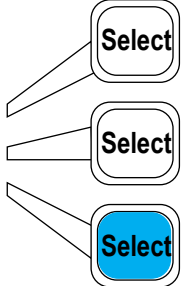
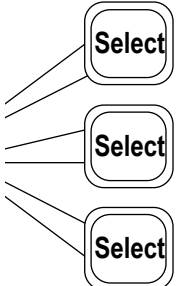
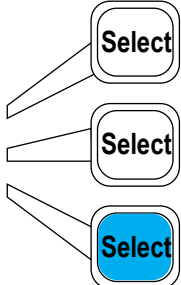
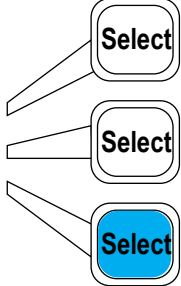
## External Presets

External selection of (up to 12) presets is accessed and turned On or Off in the System Configuration menu. This feature can be used in both normal and Hand Held modes. The selection goes into effect for the next weld cycle. When enabled, inputs can be read when either start switch is received to start a new cycle. The five user inputs (J3-17, J3-19, J3-31, J3-32, J3-33) are used to decode which preset is recalled.


- When a preset is recalled, it will be verified
- A new alarm message has been added that will indicate that a preset has not been defined (saved) or an attempt has been made to recall a preset not available for a control level
- External selection of presets will default to off. Cold start will not affect the setting

## Setting the Scale for Bar Graphs

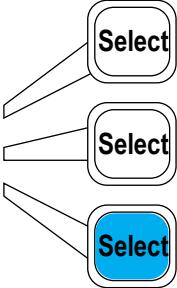
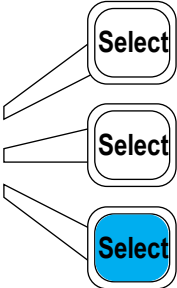
**Table 6.56** Setting the Scale for Bar Graphs

Take this action	To get this result	Key
<p>Press the <b>Select</b> key that corresponds to <b>Bar Graph Scales</b>.</p>	<pre>SYS CONFIG Pg17of19 Act Settings&gt; Amp Control    =Int Bargraph Scales&gt;</pre>	
<p>You will see the <b>SCALES</b> submenu. Press the <b>Select</b> key that corresponds to <b>Weld Scale</b> or <b>Test Scale</b> to set the scale for those graphs.</p>	<pre>SCALES Pg1of1 Weld Scale&gt; 1X Test Scale&gt; 1X</pre>	
<p>If you selected <b>Weld Scale</b> from the <b>SCALES</b> submenu, press the <b>Select</b> key that corresponds to the <b>Weld Scale</b> you want to use. Press the <b>Enter</b> key on the numeric keypad when you have set <b>Weld Scale</b> to the value you want. You can only select one value.</p>	<pre>WELD SCALE Pg1of1 1X          =On 2X          =Off 3X          =Off</pre>	
<p>If you selected <b>Test Scale</b> from the <b>SCALES</b> submenu, press the <b>Select</b> key that corresponds to the <b>Test Scale</b> you want to use. Press the <b>Enter</b> key on the numeric keypad when you have set <b>Test Scale</b> to the value you want. You can only select one value.</p>	<pre>TEST SCALE Pg1of1 1X          =Off 2X          =On 3X          =Off</pre>	


## Turning the Digital Filter On or Off

NOTICE	
	<p>Branson recommends that you set the Digital Filter to On.</p>

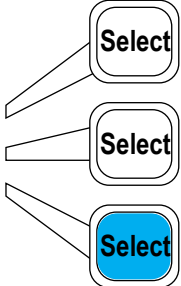
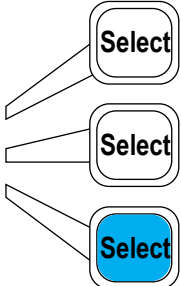
**Table 6.57** Turning the Digital Filter On or Off

Take this action	To get this result	Key
<p>Press the <b>Select</b> key that corresponds to <b>Digital Filter</b>.</p>	<pre>SYS CONFIG Pg18of19 Act Settings&gt; Bargraph Scales&gt; Digital Filter =On</pre>	
<p>Press the <b>Select</b> key repeatedly to toggle between On and Off. Press the <b>Enter</b> key on the numeric keypad when you have set <b>Digital Filter</b> to the value you want. You will return to the <b>Main Menu</b>.</p>	<pre>SYS CONFIG Pg18of19 Act Settings&gt; Bargraph Scales&gt; Digital Filter = Off</pre>	

## Setting the Frequency Offset Control

NOTICE	
	<p><b>Do not</b> use this feature unless advised to do so by Branson.</p>

**Table 6.58** Setting the Frequency Offset Control

Take this action	To get this result	Key
<p>Press the <b>Select</b> key that corresponds to <b>Freq Offset</b>.</p>	<pre>SYS CONFIG Pg19of19 Bargraph Scales&gt; Digital Filter =On Freq Offset =Int</pre>	
<p>Press the <b>Select</b> key repeatedly to toggle between Int and Ext. Press the <b>Enter</b> key on the numeric keypad when you have set <b>Freq Offset</b> to the value you want.</p> <p>You will return to the <b>Main Menu</b>.</p>	<pre>SYS CONFIG Pg19of19 Bargraph Scales&gt; Digital Filter = On Freq Offset = Ext</pre>	


## 6.9 Using the Horn Down Feature

You can use the **Horn Down** key to verify that your fixture is properly set up or to determine the absolute distance that the horn needs to travel to weld your parts. After pressing the **Horn Down** key you can press the Start Switches, or you can use manual override to bring the horn down to the position you have set *without* ultrasonic energy on by using the mechanical stop. Once the horn is in position, you can release the Start Switches in order to verify your setup. You can also disconnect air and manually bring the horn down to read distance and align your fixture.

### Using the Horn Down Feature

You can use the Horn Down feature on the Power Supply to verify that your fixture is correctly placed, so that the horn will contact your part properly.

**Table 6.59** Using the Horn Down Feature

Take this action	To get this result	Key
<p>Press the <b>Horn Down</b> key. You will see the <b>Horn Down</b> screen, indicating that you should press the <b>Start Switches</b>.</p>	<div style="border: 1px solid black; border-radius: 15px; padding: 10px; text-align: center;"> <p>HORN DOWN Pg1of1</p> <p>Press Start Switches</p> <p>Until Beep is Heard</p> </div>	

**WARNING**

Do NOT set Downspeed adjustment knob initially to a value that is greater than 20. Unexpected excessive downspeed can create a dangerous situation.

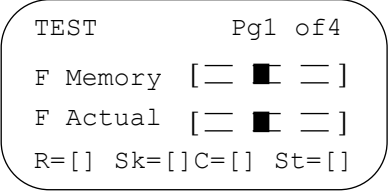
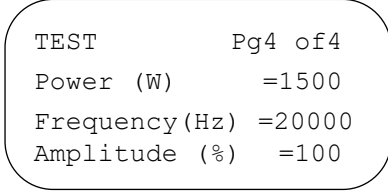
## 6.10 Using the Test Feature

You can use the **Test** key on the Power Supply to view the status of a test cycle. You can view information on the power and frequency of the test cycle and change the amplitude directly to determine its impact on the other settings through a test cycle.

### Using the Test Feature

You can use the Test key to view information about a test cycle.


**Table 6.60** Using the Test Feature

Take this action	To get this result
<p>Press the <b>Test</b> key. You will see the <b>Test</b> screen.</p>	
<p>You can view information about the on-board microprocessor in your Power Supply including frequency in memory and actual frequency, as well as the Run, Seek, Clear, and Store features.</p>	
<p>You can use the up and down arrow keys to scroll through this menu and view the power, frequency, and amplitude of the most recent cycle.</p> <p>You can use the <b>Select</b> key that corresponds to <b>Amplitude</b> and the numeric keypad to change the amplitude directly from this screen. If you choose to do this, you might want to run another test to observe how the change in amplitude impacts the other parameters.</p>	
<p>Press the <b>Go Back/Esc</b> key to exit the <b>Test</b> menu and return to the menu you were viewing before you began the <b>Test</b> procedure.</p>	




## Chapter 7: Maintenance

<b>7.1</b>	<b>2000 Series Preventive Maintenance</b> .....	<b>188</b>
<b>7.2</b>	<b>Parts Lists</b> .....	<b>192</b>
<b>7.3</b>	<b>Circuits</b> .....	<b>195</b>
<b>7.4</b>	<b>Troubleshooting</b> .....	<b>197</b>
<b>7.5</b>	<b>System Alarm Tables</b> .....	<b>199</b>
<b>7.6</b>	<b>Service Events</b> .....	<b>249</b>
<b>7.7</b>	<b>Parts Replacement</b> .....	<b>252</b>

WARNING	
	<p>When performing maintenance on the welder, make sure that no other automated systems are active.</p>

## 7.1 2000 Series Preventive Maintenance

CAUTION	
	<p>Be certain to disconnect power before performing any maintenance on the power supply or actuator.</p>

The following preventive measures help assure long term operation of your Branson 2000 Series equipment.


### 7.1.1 Periodically Clean the Equipment

Air is continuously drawn into the Branson power supply. Periodically disconnect the unit from power, remove the cover and vacuum out any accumulated dust and debris. Remove material adhering to the fan blades and motor, transistors, heat sinks, transformers, circuit boards, cooling intake vents, and exhaust ports. Filters can be added to the power supply cooling fans for dusty environments. External covers may be cleaned with a damp sponge or cloth using a solution of mild soap and water. Do not allow cleaning solution to enter the unit. To prevent rust in areas of high humidity, exposed steel surfaces, such as handles, hardware, and the main column may require a very light film of oil, such as WD-40.

### 7.1.2 Reconditioning the Stack (Converter, Booster, and Horn)

Stack components function with greatest efficiency when the mating interface surfaces are in proper condition. For 20 and 30 kHz products, a Branson Mylar® washer should be installed between the horn and booster and horn and converter. Replace the washer if torn or perforated. Stacks using Mylar washers should be inspected periodically.


Stacks used with silicone grease, as with certain 20 kHz installations and with all 40 kHz products, should be periodically reconditioned to eliminate fretting corrosion. A stack using silicone grease should be inspected periodically for corrosion. When experience is gained for specific stacks, the inspection interval can be adjusted to a longer or shorter period as required.


NOTICE	
	<p>The operating efficiency of the equipment will be greatly affected if the mating interfaces of the converter, booster, and horn are not flat, make poor contact with each other, or become corroded. A poor contact condition wastes power and makes tuning difficult. It may also affect the noise level and damage the converter.</p>

#### To recondition the interfaces:


1. Remove the stack from the actuator.
2. Disassemble the converter, booster, and horn stack. Observe the following rules:

In the event that you must disassemble a Stack, always use the correct spanner wrench and a suitable soft-faced vise to remove a horn or booster, and reverse the procedures described earlier in this Section.


CAUTION	
	<p>NEVER attempt to remove a horn or booster by holding the converter housing or booster clamp ring in a vise.</p>


NOTICE	
	<p>Use a soft-jawed vise (brass or aluminum) to remove square or rectangular horns, or horns otherwise unremovable, by reversing the procedure detailed in Section <a href="#">4.9 Assemble the Acoustic Stack</a>.</p>

3. Wipe the interfaces with a clean cloth or paper towel.
4. Examine all interfaces. If any interface is corroded or shows a dark, hard deposit, it should be reconditioned.
5. If the interfaces appear to be in good condition, go to step 13.
6. If necessary, remove the coupling studs.
7. Tape a clean sheet of #400 grit (or finer) emery cloth to a clean, smooth flat surface. A piece of glass is suitable.
8. Hold the part to be conditioned at its lower end and carefully stroke it in one direction across the emery cloth. Do not press down. the weight of the component provides enough pressure.
9. Perform a second stroke. Rotate the part 1/3 around and stroke it twice across the cloth.

NOTICE	
	<p>Use no more than two strokes in one position. Use the same number of strokes at each location.</p>

10. Turn the part the remaining 1/3 and repeat.
11. Re-examine the interface and repeat steps 8, 9, and 10 until the surface appears clean and smooth. This should not take more than 2 or 3 complete rotations of the part being reconditioned.
12. Clean the threaded hole, using a clean cloth or paper towel.
13. Replace the stud with a new one if removed. Torque M8x1-1/4 studs to 70 inch pounds (7.9 Nm). Torque the 3/8-24 studs to 290 inch pounds (32.77 Nm). Torque 1/2-20 studs to 450 inch pounds (50.84 Nm).

NOTICE	
	<p>The use of a Branson torque wrench or the equivalent is recommended. P/N 101-063-787 for 20 kHz systems and 101-063-618 for 40 kHz systems.</p>

CAUTION	
	<p>Failure to follow torque specifications may cause the stud to loosen or break, and the system to overload. The use of a Branson torque wrench or equivalent is required.</p>

14. Reassemble the stack and install it in the actuator, using the procedures in Section [4.7 Assemble the Acoustic Stack](#) of this manual.

### 7.1.3 Routine Component Replacement

The lifetime of certain parts is based on the number of cycles the unit has completed, or on hours of operation. [Table 7.1](#) lists the average number of hours or cycles one should use in determining when components should be replaced. Ambient operating temperature also affects lifetime. Higher temperatures reduce the number of cycles and hours before replacement is suggested. The charts below are for equipment operating at a temperature of 72 to 75° F (22 to 24° C).

The lifetime of system pneumatic components is influenced by the quality of the compressed air provided. All Branson systems require clean, dry, (normal) factory compressed air. When oil or moisture is present in the compressed air, the lifetime of the pneumatic components will be reduced. This table lists pneumatic parts with an average factory compressed air condition.

**Table 7.1** Component Replacements Based on Cycles Run

Cycles	Component
At 10 Million Cycles	Air cylinder
	Hydraulic snubber
At 20 Million Cycles	Base Start Switches
	Proportional valve
	Air Filter, coalescing*
	Solenoid valves

**Table 7.1** Component Replacements Based on Cycles Run

Cycles	Component
At 40 Million Cycles	Pressure regulator
	Air Filter, 5 micron*
	Cooling valve
	S-Beam Load Cell Assembly
	Encoder Assembly
	Linear Bearing (2" stroke or greater)

\*Totally dependent on quality of house air supply.

## 7.2 Parts Lists

This section provides lists of replacement parts, system cables, and suggested spares.

### 7.2.1 Replacement Parts

**Table 7.2** Replacement Parts List for 2000X Power Supply

Component	EDP Number
DC Power Supply Module*	200-132-294R
Line Board*	100-242-1199R (100-242-1230R for 4kW units)
System Controller Board*	101-063-824
<b>Power Supply Module*</b>	
400W / 40 kHz      digital	100-244-039R
800W / 40 kHz      digital	159-244-063R
750W / 30 kHz      digital	100-244-104R
1.5kW / 30 kHz      digital	159-244-065R
1.25kW / 20 kHz      digital	100-244-102R
2.5kW / 20 kHz      digital	100-244-103R
4kW / 20 kHz          digital	159-244-075R
Switch, On / Off; 15A; DPST	1032510, 1032496
User I/O Board w/ mtg. bracket*	100-246-1197R
<b>Washer, Mylar</b>	
Kit, 10 each (1/2 in. and 3/8 in.)	100-063-357
Kit, 150 each (1/2 in.)	100-063-471
Kit, 150 each (3/8 in.)	100-063-472
Kit, 10 each (3/8 in., 30 kHz)	100-063-632
Fan	100-126-015R
CR2032 Battery for BBRAM	200-262-003
Cover	100-032-454
Cover Screws	200-298-254 (6 ea) 200-298-044 (1 ea)
VF Display	200-220-014
Line Cord	100-246-1371

**Table 7.2** Replacement Parts List for 2000X Power Supply


Component	EDP Number
<b>Miscellaneous</b>	
Other parts such as wrenches, silicon grease, studs, etc., are found in <a href="#">Chapter 4: Installation and Setup</a> .	
*Each of these items must be replaced as a unit.	

## 7.2.2 System Cables

You can order the following cables. If the cable you require is not listed, refer to [4.3.1 Cables](#) of this manual for part number and cable model number.

**Table 7.3** 2000-Series System Cables (External)

P/N	Description	Cable Model
101-241-202	Cable, Remote Interface 8' to remote pneumatics package (ao actuator)	J924
101-241-203	Cable, Actuator Interface 8'	J925S
101-241-204	Cable, Actuator Interface 15'	J925S
101-241-205	Cable, Actuator Interface 25'	J925S
101-241-206	Cable, Actuator Interface 50'	J925S
101-240-020R	Cable, Start 8'	J911
101-240-015R	Cable, Start 15'	J911
101-240-010R	Cable, Start 25'	J911
101-240-168R	Cable, Start 50'	J911
101-241-207	Cable, User I/O 8'	J957S
101-241-208	Cable, User I/O 15'	J957S
101-241-209	Cable, User I/O 25'	J957S
101-241-258	Cable, User I/O 50'	J957S
101-240-017	Cable, RF CR & CJ20 8'	J931S
101-240-012	Cable, RF CR & CJ20 15'	J931S
101-240-007	Cable, RF CR & CJ20 25'	J931S
101-200-200	Cable, RF CR & CJ20 50'	J931
101-240-176	Cable, RF CR & CJ20 8' CE	J931CS
101-240-177	Cable, RF CR & CJ20 15' CE	J931CS
101-240-178	Cable, RF CR & CJ20 25' CE	J931CS
101-240-199	Cable, RF CR & CJ20 50' CE	J931C
100-246-630	Cable, Ground Detect	-

NOTICE	
	<p>Cables identified for 'CJ-20 Converters' are for those Converters when they are installed in Branson 2000 Actuators. The Cable connects to the Actuator.</p>

## 7.2.3 Suggested Spares

**Table 7.4** Suggested Spares

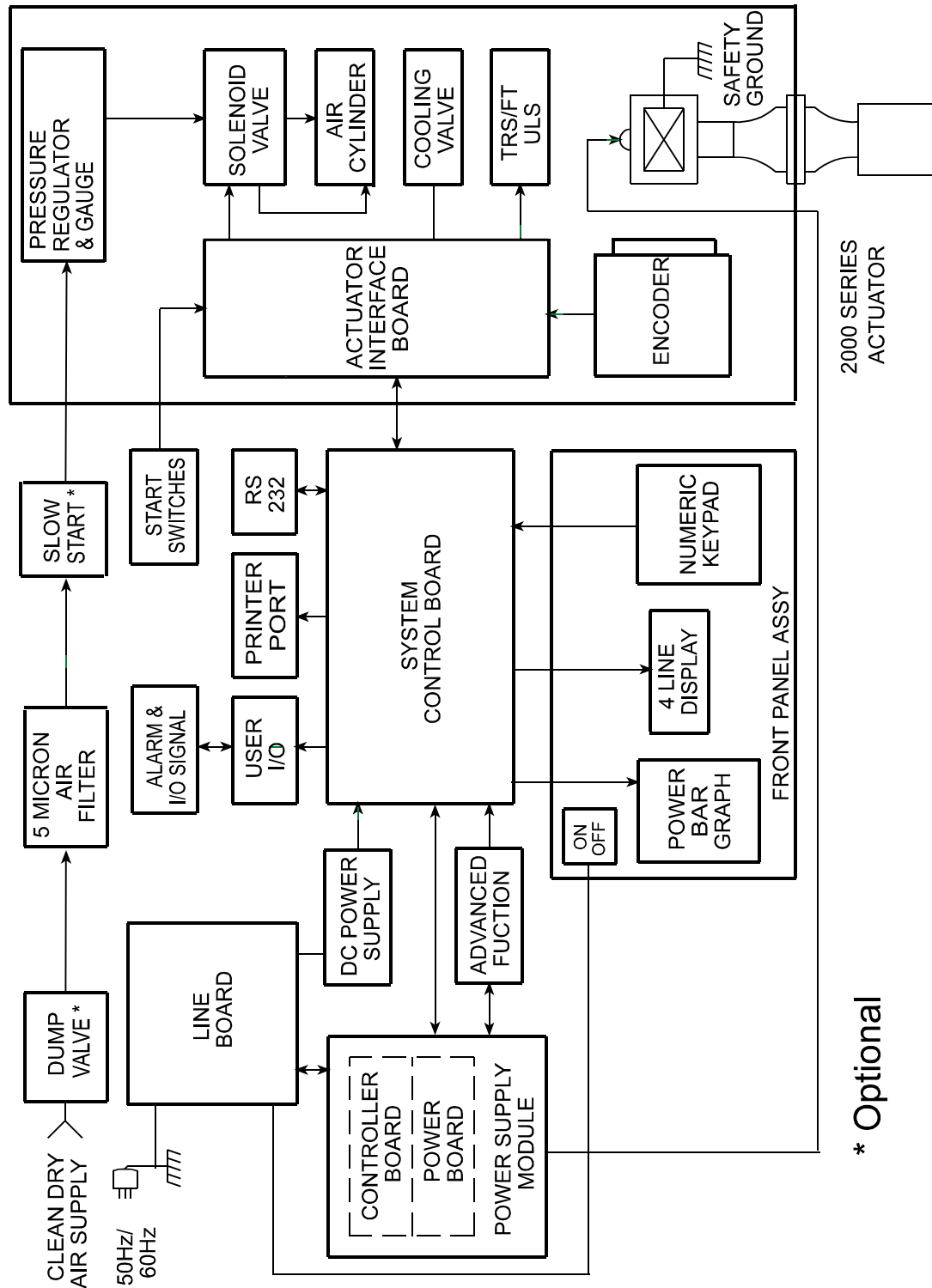
Description	EDP#	1-4 Units	6-12 Units	14+ Units
Replacement 2000X Control Board	101-063-1112	0	1	1
400w power supply module, digital	159-244-064R	0	0	1
800w power supply module, digital	159-244-063R	0	0	1
1.5kw power supply module, digital	159-244-065R	0	0	1
1.25kw power supply module, digital	100-244-107R	0	0	1
2.5kw power supply module, digital	100-244-103R	0	0	1
4kW power supply module, digital	159-244-075R	0	0	1
Front Panel Switch	1032510, 1032496	1	1	2
Line Board	100-242-1199R (100-242-1230R for 4kW units)	0	0	1
Line Fuse (s), 20a	200-049-015R	2	4	6
DC Fan	100-126-015R	2	2	4
Fan Filter Kit	101-063-614	*	*	*
I/O Board	100-242-1197R	0	1	2
Line Cord	100-246-947	0	1	2
Front Panel Display	200-220-014	0	1	1
Membrane Panel	100-242-631R	0	0	1
DC Power Supply	200-132-294R			
RF Harness	100-246-949R	0	0	1
Front Bezel	100-004-030R	0	0	1

\* Quantity varies depending on amount of airborne particulate in your environment.

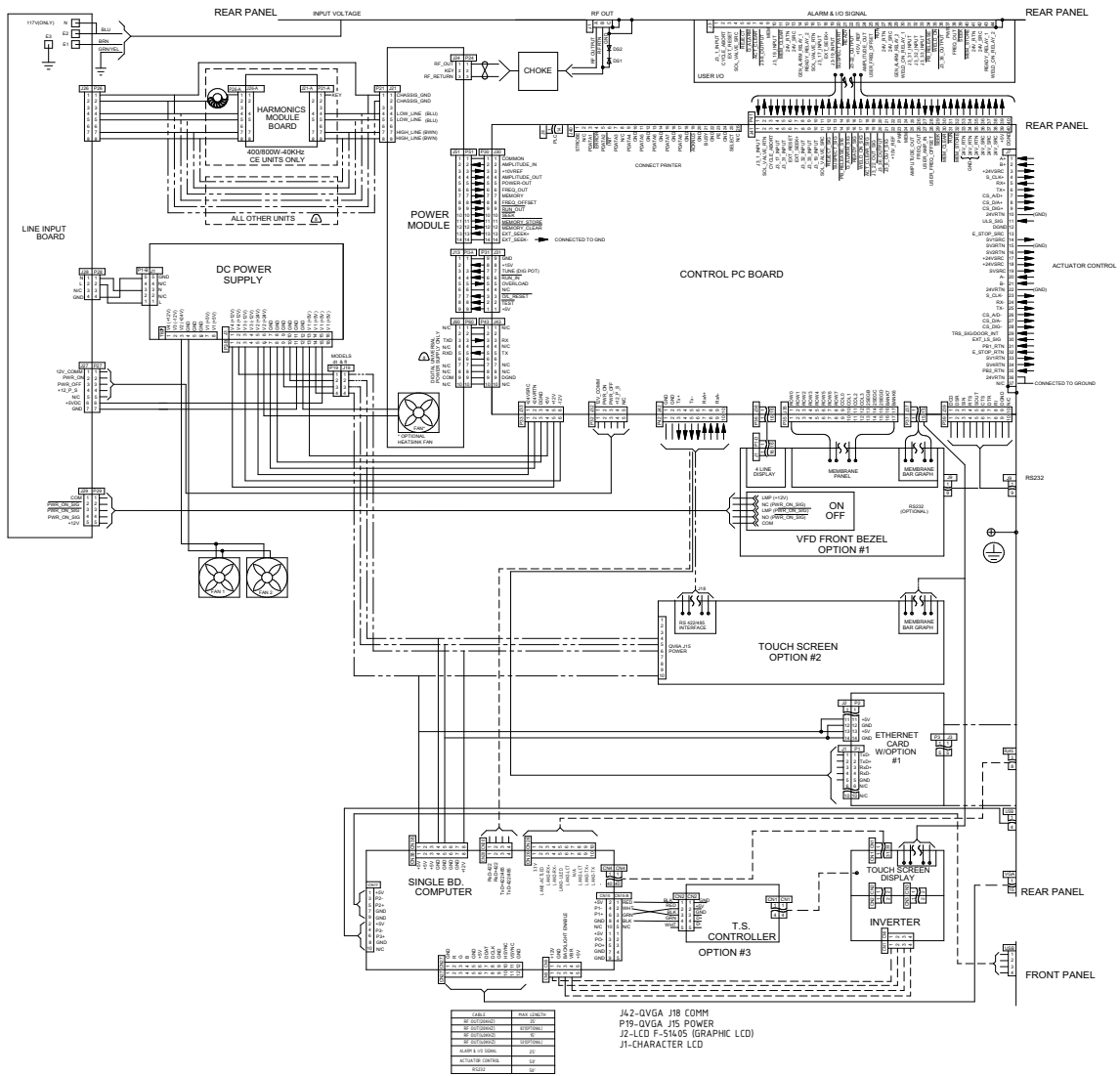
## 7.3 Circuits

Figure 7.1 shows a block diagram of the 2000 power supply and actuator. Figure 7.2 is an interconnect diagram of the 2000 power supply.

Figure 7.1 Block Diagram, Power Supply and Actuator



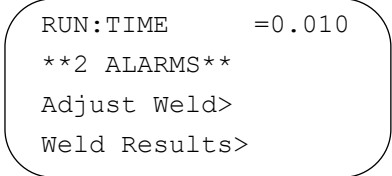
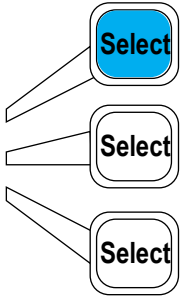
**Figure 7.2** Interconnect Diagram, Power Supply




## 7.4 Troubleshooting

When the 2000X Power Supply encounters a situation that is outside of the normal conditions, an alarm is generated. If there is any alarm condition, the Front Panel displays the number of alarms and generates an audible alarm.


**Table 7.5** Alarm Message

<p>When you press the <b>Select</b> key that corresponds to an Alarm, you will see the actual Display Message. Press the Select Key next to the display message for the corrective action. If no additional information is displayed, refer to the System Alarm tables. To change one or both of the limits shown, press the <b>Select</b> key that corresponds to the limit you want to set and use the numeric keypad to set the limit to another value.</p>	 <pre> RUN:TIME      =0.010 **2 ALARMS** Adjust Weld&gt; Weld Results&gt;                     </pre>	
--	--	---

NOTICE	
	<p>If you have been directed to this Section from an alarm message on the Power Supply screen, go directly to the table for the alarm type specified in the message. Location of the alarm tables is detailed in the following text.</p>

This section details the alarm conditions that you can encounter while using the 2000X Power Supply. There are eight classes of alarms: **Cycle Modified**, **Failure of**, **No Cycle**, **Setup**, and **Suspect**, **Reject**, **Overload**, and **Note**. Following is a brief description of each type of alarm, followed by [Table 7.6](#) through [Table 7.12](#) which detail alarm messages, causes, and corrective actions for each type of alarm.

- A Cycle Modified alarm ([Table 7.6 Cycle Modified Alarms and Messages, with Probable Cause and Corrective Action](#)) occurs when the most recent weld cycle has been modified by some event. For example, if the amplitude step did not occur as requested. The specific alarm that has occurred is indicated by the message on your display, and will advance the general alarm counter. If you encounter numerous or successive cycle modified alarms, review your weld parameter setup. See individual alarms for advancement of cycle counter
- A Failure of alarms, Equipment Failure, ([Table 7.7 Failure of Alarms and Messages, with Probable Cause and Corrective Action](#)) are those which might occur for hardware failure, or hardware disconnected. For example, if the door were open to replace a stack, a Door/Trigger Switch alarm would occur. The specific equipment failure that has occurred is indicated by the message on your display. Repair or replace the equipment before you run another weld cycle. Failure Of: alarms will advance the general alarm counter. Call Branson Product Support at (203) 796-0551 or (203) 796-0355 for more detailed information on repairing your equipment

WARNING	
	<p>You should always power down your system prior to repairing any portion of it.</p>

- A No Cycle alarm ([Table 7.8 No Cycle Alarms and Messages, with Probable Cause and Corrective Action](#)) occurs when the most recent weld cycle was aborted before any weld took place. The specific no weld failure that has occurred is indicated by the message on your display. No Cycle alarms will advance the general alarm counter, but will not advance the cycle counter. You should continue with the next weld cycle; in most cases the part can be re-used
- A Suspect or Reject alarm ([Table 7.9 Suspect/Reject Alarms and Messages, with Probable Cause and Corrective Action](#)) occurs when the most recent weld cycle fell outside your programmed limits. The specific conflict that has occurred is indicated by the message on your display. Suspect/Reject alarms will advance the general alarm counter, but only once per cycle regardless of the number of alarms generated. You should inspect any part that was welded during a cycle that resulted in an alarm. If you encounter numerous or successive alarms you should review your weld parameter setup
- A Setup alarm ([Table 7.10 Setup Alarms and Messages, with Probable Cause and Corrective Action](#)) occurs when you have entered parameters that create a conflict with other parameters. For example, trying to step an amplitude at weld time 1.000 seconds, but the weld time is only set for 0.500 seconds. The specific conflict that has occurred is indicated by the message on your display. All setup alarms must be resolved before a new cycle can be run. Setup alarms will advance the general alarm counter, but will not advance the cycle counter. If you are uncertain as to the cause of the conflict, it might be helpful to record your current setup so that you can see your entire setup, resolve the conflict, and proceed
- An Overload alarm ([Table 7.11 Overload Alarms](#)) occurs when your ultrasonic power supply has overloaded. Overload alarms advance the general alarms counter. The specific overload that has occurred is indicated by the message on your display
- Note alarms ([Table 7.12 Note Alarms](#)) occur to alert you that an alarm is imminent or the cycle ran with authorized modifications

## 7.5 System Alarm Tables

The following tables detail alarms that you can encounter on the 2000X Power Supply, listed alphabetically by the Display Message that is presented on the front panel. The message on the display panel of the Power Supply is shown in the first column. The second and third columns indicate the condition that led to the alarm and the corrective action you should take.

### 7.5.1 Alarm Index

An alphabetical list of the alarms that appear on the system display is included in [Appendix B: Alarm Index](#). All alarm page numbers are hyper-linked to the full description, which describes the cause of the alarm condition and the steps to resolve it.

### 7.5.2 Cycle Modified Alarms

**Table 7.6** Cycle Modified Alarms and Messages, with Probable Cause and Corrective Action

Display Message	Alarm Condition/Cause	Corrective Action
ABS Cutoff	The absolute distance cutoff you set was reached. The main parameter you set for the weld cycle was not used to the end of the cycle.	Manually inspect the part. If the part is acceptable, you might want to adjust your main parameter to avoid this alarm.
Ground Detect Abort	The cycle was aborted because ground detect occurred during Weld or Hold	Manually inspect the part. If the part is acceptable, you might want to adjust your main parameter to avoid this alarm.
Ground Detect Abort (Message also appears in "No Cycle Alarms and Messages.")	The cycle was aborted because ground detect occurred during weld or hold.	Verify part placement and distance parameters.
Max Timeout	The ultrasonics ran for the maximum allowed time because the set parameter could not be achieved.	Manually inspect the part. If the part is acceptable, you might want to adjust your main parameter to avoid this alarm.
No Amplitude Step	The amplitude time step trigger was not reached.	Manually inspect the part. If the part is acceptable, turn amplitude stepping off. If the part is not acceptable, you might want to adjust your main parameter.
ABS Cutoff	The absolute distance cutoff you set was reached. The main parameter you set for the weld cycle was not used to the end of the cycle.	Manually inspect the part. If the part is acceptable, you might want to adjust your main parameter to avoid this alarm.

**Table 7.6** Cycle Modified Alarms and Messages, with Probable Cause and Corrective Action

Display Message	Alarm Condition/Cause	Corrective Action
Ground Detect Abort	The cycle was aborted because ground detect occurred during Weld or Hold.	Manually inspect the part. If the part is acceptable, you might want to adjust your main parameter to avoid this alarm.
Ground Detect Abort (Message also appears in "No Cycle Alarms and Messages.")	The cycle was aborted because ground detect occurred during weld or hold.	Verify part placement and distance parameters.
Max Timeout	The ultrasonics ran for the maximum allowed time because the set parameter could not be achieved.	Manually inspect the part. If the part is acceptable, you might want to adjust your main parameter to avoid this alarm.
No Amplitude Step	The amplitude time step trigger was not reached.	Manually inspect the part. If the part is acceptable, turn amplitude stepping off. If the part is not acceptable, you might want to adjust your main parameter.
No Amplitude Step	The amplitude step at external signal input was not received.	Make sure Ext Signal is defined in the User I/O.
No Amplitude Step	The amplitude step at external signal input was not received.	Manually inspect the part. If the part is acceptable, turn amplitude stepping off. If the part is not acceptable, you might want to adjust your main parameter.
No Amplitude Step	The amplitude power step level was not reached.	Manually inspect the part. If the part is acceptable, turn amplitude stepping off. If the part is not acceptable, you might want to adjust your main parameter.
No Amplitude Step	The amplitude energy step trigger was not reached.	Manually inspect the part. If the part is acceptable, turn amplitude stepping off. If the part is not acceptable, you might want to adjust your main parameter.

**Table 7.6** Cycle Modified Alarms and Messages, with Probable Cause and Corrective Action

<b>Display Message</b>	<b>Alarm Condition/Cause</b>	<b>Corrective Action</b>
No Amplitude Step	The amplitude collapse distance step trigger was not reached.	Manually inspect the part. If the part is acceptable, turn amplitude stepping off. If the part is not acceptable, you might want to adjust your main parameter.
No Amplitude Step	The amplitude step at external signal input was not received.	Manually inspect the part. If the part is acceptable, turn amplitude stepping off. If the part is not acceptable, you might want to adjust your main parameter.
No Amplitude Step	The amplitude power step level was not reached.	Manually inspect the part. If the part is acceptable, turn amplitude stepping off. If the part is not acceptable, you might want to adjust your main parameter.
No Amplitude Step	The amplitude energy step trigger was not reached.	Manually inspect the part. If the part is acceptable, turn amplitude stepping off. If the part is not acceptable, you might want to adjust your main parameter.
No Amplitude Step	The amplitude collapse distance step trigger was not reached.	Manually inspect the part. If the part is acceptable, turn amplitude stepping off. If the part is not acceptable, you might want to adjust your main parameter.
Sonics Disabled		Remove Sonics Disable input.
Peak Power Cutoff	The peak power cutoff was reached. The main parameter you set for the weld cycle was not used.	Manually inspect the part. If the part is acceptable, you might want to adjust your main parameter to avoid this alarm.
Trigger Lost in Hold	The cycle was aborted because trigger force on the part was lost.	Verify that there is adequate pressure from your pneumatic supply.
Peak Power Cutoff	The peak power cutoff was reached. The main parameter you set for the weld cycle was not used.	Manually inspect the part. If the part is acceptable, you might want to adjust your main parameter to avoid this alarm.

**Table 7.6** Cycle Modified Alarms and Messages, with Probable Cause and Corrective Action

Display Message	Alarm Condition/Cause	Corrective Action
Trigger Lost in Hold	The cycle was aborted because trigger force on the part was lost.	Verify that there is adequate pressure from your pneumatic supply.
Trigger > End Force	The force at the end of the weld is less than the trigger force you set.	Increase your downspeed and/or system pressure. If you very frequently receive this alarm, contact Branson
Trigger Lost in Weld	The cycle was aborted because trigger force on the part was lost.	Verify that there is adequate pressure from your pneumatic supply. Verify stroke length < 3.75"

## 7.5.3 Failure of Alarms and Messages

**Table 7.7** Failure of Alarms and Messages, with Probable Cause and Corrective Action

Display Message	Alarm Condition/Cause	Corrective Action
Actuator Clear Function	The carriage is home before the Actuator clear condition was met.	Make sure the linear encoder cable is connected properly. Replace Linear Encoder. Repair/replace Control Board.
Actuator Clear Function	The carriage is home before the Actuator clear condition was met.	Make sure the linear encoder cable is connected properly. Replace Linear Encoder. Repair/replace Control Board.
Actuator Type	Actuator type detected at power up is different from the actuator type that was used on the last weld cycle. Checked at power up and after E-Stop is removed.	Verify serial number (excepting ae/ao) and type, then reset. If you did not change the actuator, troubleshoot your system.
Actuator NovRam Error Code = 10	The Actuator NovRam has corrupted data	Perform a Cold Start. Check setup/cable. Repair/replace Interface board in actuator.
Actuator NovRam Error Code = 10	The Actuator NovRam has corrupted data	Perform a Cold Start. Check setup/cable. Repair/replace Interface board in actuator.
Actuator NovRam Error Code = 20	Cylinder size is not 1.5, 2.0, 2.5, 3.0, 50mm, 63mm, 80mm, or Custom.	Perform a Cold Start. Check setup/cable. Repair/replace Interface board in actuator.

**Table 7.7** Failure of Alarms and Messages, with Probable Cause and Corrective Action

<b>Display Message</b>	<b>Alarm Condition/Cause</b>	<b>Corrective Action</b>
Actuator NovRam Error Code = 30	Stroke length is not 4", 5", 6", 7", 8", 80mm, 160mm, or Custom.	Perform a Cold Start. Check setup/cable. Repair/replace Interface board in actuator.
Actuator NovRam Error Code = 40	When each successive element in the Pressure Sensor Calibration Table is not greater than the preceding one.	Perform a Cold Start. Check setup/cable. Repair/replace Interface board in actuator.
Actuator NovRam Error Code = 50	When each successive element in the Load Cell Table is not larger than the preceding one.	Perform a Cold Start. Check setup/cable. Repair/replace Interface board in actuator.
Actuator NovRam Error Code = 60	Could not write to the actuator NovRam.	Perform a Cold Start. Check setup/cable. Repair/replace Interface board in actuator.
Door/Trigger Switch	The actuator door (front cover) is ajar or missing, or the Trigger Switch was not engaged.	Secure the Actuator door or verify the Trigger Switch electrical connections and continuity.
External Switch	The external input is either improperly configured, in the wrong condition, or failed.	Reconfigure properly, replace, or set proper condition.
Horn Return Timeout	The Horn did not retract to the home position after the weld was completed and within the correct time. The Horn might be jammed or air pressure might have failed. The Upper Limit Switch might also have failed.	Verify that air pressure is correct. Check for obstructions or jams that would prevent the Horn from returning. Verify the operation of the Upper Limit Switch.
P/S NovRam	The power supply NovRam failed. It is checked only at power up.	Repair/replace Control Board.
Preset Data/BBR	Corrupted data in preset. Checked at power up.	Replace BBR or repair/replace the Control Board. Replace battery.
Pretrigger Timeout	Pretrigger has not occurred within 10 seconds of carriage leaving home (of upper limit becoming inactive).	Check the distance setting for pretrigger to be sure the carriage is traveling at least that far. Repair/replace Control Board.

**Table 7.7** Failure of Alarms and Messages, with Probable Cause and Corrective Action

<b>Display Message</b>	<b>Alarm Condition/Cause</b>	<b>Corrective Action</b>
Recalibrate Actuator Error Code = 100	Either the Actuator serial number is different from the last time power was turned on, or your new setup requires a calibration.	Run an Actuator Calibration procedure from the Alarm Information screen or from Calibrate in the Main Menu.
Horn Return Timeout	The Horn did not retract to the home position after the weld was completed and within the correct time. The Horn might be jammed or air pressure might have failed. The Upper Limit Switch might also have failed.	Verify that air pressure is correct. Check for obstructions or jams that would prevent the Horn from returning. Verify the operation of the Upper Limit Switch.
P/S NovRam	The power supply NovRam failed. It is checked only at power up.	Repair/replace Control Board.
Preset Data/BBR	Corrupted data in preset. Checked at power up.	Replace BBR or repair/replace the Control Board. Replace battery.
Pretrigger Timeout	Pretrigger has not occurred within 10 seconds of carriage leaving home (of upper limit becoming inactive).	Check the distance setting for pretrigger to be sure the carriage is traveling at least that far. Repair/replace Control Board.
Recalibrate Actuator Error Code = 100	Either the Actuator serial number is different from the last time power was turned on, or your new setup requires a calibration.	Run an Actuator Calibration procedure from the Alarm Information screen or from Calibrate in the Main Menu.
Recalibrate Actuator Error Code = 200	A collapse of more than 0.2500" and less than 35 lbs. of force was reached.	Run an Actuator Calibration procedure from the Alarm Information screen or from Calibrate in the Main Menu. Also check part alignment.
Recalibrate Actuator Error Code = 300	A change in horn weight of 6-7 lbs since the last power down or E-stop.	Run an Actuator Calibration procedure from the Alarm Information screen or from Calibrate in the Main Menu.
Recalibrate Actuator Error Code = 400	Carriage travel greater than -0.25 after trigger.	Run an Actuator Calibration procedure from the Alarm Information screen or from Calibrate in the Main Menu. Check Step Force and Hold Force for large decreased values.

**Table 7.7** Failure of Alarms and Messages, with Probable Cause and Corrective Action

<b>Display Message</b>	<b>Alarm Condition/Cause</b>	<b>Corrective Action</b>
Recalibrate Actuator Error Code = 600	Actuator type has changed.	Run an Actuator Calibration procedure from the Alarm Information screen or from Calibrate in the Main Menu.
Recalibrate Actuator Error Code = 700	In Horn Down, a bad Trigger has occurred.	Run an Actuator Calibration procedure from the Alarm Information screen or from Calibrate in the Main Menu.
Recalibrate Actuator Error Code = 800	Part contact flag has been lost.	Run an Actuator Calibration procedure from the Alarm Information screen or from Calibrate in the Main Menu.
Recalibrate Actuator Error Code = 900	Carriage travels greater than 0.250 and less than 35 lbs. force was developed after part contact and before trigger.	Run an Actuator Calibration procedure from the Alarm Information screen or from Calibrate in the Main Menu.  Check Step Force and Hold Force for large increasing values.
Recalibrate Actuator Error Code = 1000	Upgrade from version 6.00 aed to version 8.0 has been detected.	Run an Actuator Calibration procedure from the Alarm Information screen or from Calibrate in the Main Menu, using maximum stroke length.
Recalibrate Actuator Error Code = 1100	Upgrade from version 8.06 to 8.04 or 8.05 has been detected.	Run an Actuator Calibration procedure from the Alarm Information screen or from Calibrate in the Main Menu.
Recalibrate Actuator Error Code = 1200	A Reset Act. Cal has been done. The restored value is from an 8.04 or 8.05 calibration.	Run an Actuator Calibration procedure from the Alarm Information screen or from Calibrate in the Main Menu.
Start Sw Time	You did not activate both start switches within the required time interval.	Activate both start switches at the same time to rerun the cycle.
Start Switch Closed	The start switch(es) are still active two seconds after the carriage is home (ULS is active).	For manual operation: Release the Start Switches when the beep sounds. For automated operation: The PLC (Programmable Logic Controller) should release the start signal when the Weld On signal or Start Switch release signal is active.
Start Sw Time	You did not activate both start switches within the required time interval.	Activate both start switches at the same time to rerun the cycle.

**Table 7.7** Failure of Alarms and Messages, with Probable Cause and Corrective Action

Display Message	Alarm Condition/Cause	Corrective Action
Start Switch Closed	The start switch(es) are still active two seconds after the carriage is home (ULS is active).	For manual operation: Release the Start Switches when the beep sounds. For automated operation: The PLC (Programmable Logic Controller) should release the start signal when the Weld On signal or Start Switch release signal is active.
Start Switches Lost	Checked after both start switches, and before trigger. There is a 10 ms debounce time before considered lost.	Press start switches again.
Thermal Overload	Thermal sensors on the Power Supply indicate that the temperature is above the maximum operating temperature.	Lower the duty cycle by decreasing the on time or increasing the off time. Ensure fans are operational and internal components are free of dust.
Thermal Overload	Thermal sensors on the Power Supply indicate that the temperature is above the maximum operating temperature.	Lower the duty cycle by decreasing the on time or increasing the off time. Ensure fans are operational and internal components are free of dust.
Trigger Switch	Trigger Switch Failed. Checked during ready, during test ready and during power up.	The Recal Actuator line and submenu will only appear on AED actuators. Doing a calibration will reset this alarm.
Ultrasonics P/S	Checked during power up. Seek was requested but no run signal detected, or the amplitude from the Power output is less than 2%. A DUPS communication error occurred.	Contact Branson. Repair/replace the Power Supply Module.
Upper Limit Switch	Upper Limit Switch was not engaged at the end of weld cycle. The switch might have failed or the electrical wiring might be loose.	Verify the electrical connections for the Upper Limit Switch or replace the switch.
Ultrasonics P/S	Checked during power up. Seek was requested but no run signal detected, or the amplitude from the Power output is less than 2%. A DUPS communication error occurred.	Contact Branson. Repair/replace the Power Supply Module.

**Table 7.7** Failure of Alarms and Messages, with Probable Cause and Corrective Action

<b>Display Message</b>	<b>Alarm Condition/Cause</b>	<b>Corrective Action</b>
Upper Limit Switch	Upper Limit Switch was not engaged at the end of weld cycle. The switch might have failed or the electrical wiring might be loose.	Verify the electrical connections for the Upper Limit Switch or replace the switch.
USB Memory Full	Data was selected to be saved on the USB memory stick, but the memory stick is now full.	Welding will be stopped until corrected. If all data from the weld will not fit, then no data will be written. All data from any given weld cycle must be written on one USB stick.
USB Memory Lost	The USB memory stick has been removed or it is not functional.	Since weld data was configured to be saved on the USB stick, welding must be stopped until either the USB stick is functional or weld data is no longer required to be saved.
Wrong Actuator	The Power Supply has detected an Actuator that cannot be used with a Power Supply of this type.	Use the correct Actuator for this Power Supply.
Wrong Actuator	The Power Supply has detected an Actuator that cannot be used with a Power Supply of this type.	Use the correct Actuator for this Power Supply.

## 7.5.4 No Cycle Alarms and Messages

**Table 7.8** No Cycle Alarms and Messages, with Probable Cause and Corrective Action

<b>Display Message</b>	<b>Alarm Condition/Cause</b>	<b>Corrective Action</b>
Abs Before Trg	The absolute distance has been reached before trigger. This alarm in other modes means the absolute cutoff distance has been reached before trigger.	Reset your absolute distance parameter through the Alarm Information screen or the Setup menu.
Amp Step Before Trg	The amplitude step trigger has been detected within 2 ms of start of weld time.	Reset your amplitude step parameter through the Alarm Information screen or the Setup menu.

**Table 7.8** No Cycle Alarms and Messages, with Probable Cause and Corrective Action

Display Message	Alarm Condition/Cause	Corrective Action
Abs Before Trg	The absolute distance has been reached before trigger. This alarm in other modes means the absolute cutoff distance has been reached before trigger.	Reset your absolute distance parameter through the Alarm Information screen or the Setup menu.
Amp Step Before Trg	The amplitude step trigger has been detected within 2 ms of start of weld time.	Reset your amplitude step parameter through the Alarm Information screen or the Setup menu.
Trg Delay Timeout	Ext trigger delay has been turned on, but the assigned input did not go inactive within the 30 seconds allowed.	Check external timing. Activate Ext Trg Delay.
Ground Detect	The ground detect input is either improperly configured, in the wrong condition or failed.	Reconfigure properly, change condition or replace faulty input.
Ground Detect Abort (This message also appears in the Cycle Modified Alarms and Messages.)	The cycle was aborted because ground detect occurred before trigger.	Verify part placement and distance parameters.
Missing Part Abort	Checked during downstroke. The missing part minimum distance has not been reached before trigger occurred or the maximum distance has been exceeded before trigger occurred.	Insert a part into the fixture. Use the horn down feature to determine the distance to the part, and reset the minimum and maximum settings as necessary through the Alarm Information screen or Setup menu.
Trig Before Pretrig	The cycle was aborted because the trigger force was reached before the pretrigger distance.	Reset your pretrigger distance in the setup menu.
Missing Part Abort	Checked during downstroke. The missing part minimum distance has not been reached before trigger occurred or the maximum distance has been exceeded before trigger occurred.	Insert a part into the fixture. Use the horn down feature to determine the distance to the part, and reset the minimum and maximum settings as necessary through the Alarm Information screen or Setup menu.
Trig Before Pretrig	The cycle was aborted because the trigger force was reached before the pretrigger distance.	Reset your pretrigger distance in the setup menu.

**Table 7.8** No Cycle Alarms and Messages, with Probable Cause and Corrective Action

<b>Display Message</b>	<b>Alarm Condition/Cause</b>	<b>Corrective Action</b>
Trig Before Pretrig	Trigger has occurred before pre-trigger distance, upper limit switch is inactive, or pre-trigger time delay has not timed out.	Check each condition and correct where necessary.
Trigger Timeout	Trigger force was not achieved within the 10 second allowed time.	Verify that the part is in the fixture; verify that there is adequate pressure from your pneumatic supply. Verify stroke length <3.75"
Trigger Timeout	Trigger force was not achieved within the 10 second allowed time.	Verify that the part is in the fixture; verify that there is adequate pressure from your pneumatic supply. Verify stroke length <3.75"
Abs Before Trg	The absolute distance has been reached before trigger. This alarm in other modes means the absolute cutoff distance has been reached before trigger.	Reset your absolute distance parameter through the Alarm Information screen or the Setup menu.
Amp Step Before Trg	The amplitude step trigger has been detected within 2 ms of start of weld time.	Reset your amplitude step parameter through the Alarm Information screen or the Setup menu.
Abs Before Trg	The absolute distance has been reached before trigger. This alarm in other modes means the absolute cutoff distance has been reached before trigger.	Reset your absolute distance parameter through the Alarm Information screen or the Setup menu.
Amp Step Before Trg	The amplitude step trigger has been detected within 2 ms of start of weld time.	Reset your amplitude step parameter through the Alarm Information screen or the Setup menu.

## 7.5.5 Suspect/Reject Alarms and Messages

**Table 7.9** Suspect/Reject Alarms and Messages, with Probable Cause and Corrective Action

Display Message	Alarm Condition/Cause	Corrective Action
+ R Col Dist Limit	The collapse distance used in the most recent weld was greater than the upper reject limit you set.	Discard the part. If you encounter numerous or successive alarms with good parts, you might change your reject collapse distance limits.
+ S Col Dist Limit	The collapse distance used in the most recent weld was greater than the upper suspect limit you set.	Manually inspect the part for a good weld. If you encounter numerous or successive alarms with good parts, you might change your suspect collapse distance limits.
+ S Trg Dist Limit	The trigger distance used in the most recent weld was greater than the upper suspect limit you set.	Manually inspect the part for a good weld. If you encounter numerous or successive alarms with good parts, you might change your suspect trigger distance limits.
+R Abs Dist Limit	The actual distance value exceeded the plus reject absolute distance limit.	Discard the part if you encounter numerous or successive alarms with good parts. Consider changing your Absolute settings.
+R Energy Limit	The actual energy value exceeded the plus reject energy limit.	Discard the part if you encounter numerous or successive alarms with good parts. Consider changing your Energy settings.
+R Weld Force Limit	The actual Weld Force exceeded the plus Reject Weld Force limit.	Discard the part if you encounter numerous or successive alarms with good parts. Consider changing your Weld Force settings.
+R Pk Power Limit	The actual peak power value exceeded the plus reject peak power limit.	Discard the part if you encounter numerous or successive alarms with good parts. Consider changing your Peak Power settings.

**Table 7.9** Suspect/Reject Alarms and Messages, with Probable Cause and Corrective Action

<b>Display Message</b>	<b>Alarm Condition/Cause</b>	<b>Corrective Action</b>
+R Time Limit	The actual time value exceeded the plus reject time limit.	Discard the part if you encounter numerous or successive alarms with good parts. Consider changing your Time settings or your reject time limits.
+R Trg Dist Limit	The actual trigger distance value exceeded the plus reject trigger distance limit.	Adjust + reject trigger distance limit through the Alarm Information screen or Setup menu. Discard the part if you encounter numerous or successive alarms.
+R Weld Force Limit	Actual Weld Force did not reach minus reject Weld Force limit.	Adjust +reject weld force through the Alarm Information screen or Setup menu. Discard the part if you encounter numerous or successive alarms.
+S Abs Dist Limit	The actual absolute distance value did not reach the plus suspect absolute distance limit.	Inspect your parts. For numerous or successive alarms, you might adjust +suspect trigger distance limit through the Alarm Information screen or Setup menu.
+S Col Dist Limit	The actual collapse distance value exceeded the plus suspect collapse distance limit.	Inspect your parts. For numerous or successive alarms, you might adjust the collapse distance value through the Alarm Information screen or Setup menu.
+S Energy Limit	The actual energy value exceeded the plus suspect energy limit.	Inspect your parts. For numerous or successive alarms, you might adjust the Energy value through the Alarm Information screen or Setup menu.
+S Weld Force Limit	The actual Weld Force exceeded the plus suspect Weld Force limit.	Inspect your parts. For numerous or successive alarms, you might adjust the Weld Force value through the Alarm Information screen or Setup menu.

**Table 7.9** Suspect/Reject Alarms and Messages, with Probable Cause and Corrective Action

<b>Display Message</b>	<b>Alarm Condition/Cause</b>	<b>Corrective Action</b>
+S Pk Power Limit	The actual peak power value exceeded the plus suspect peak power limit.	Inspect your parts. For numerous or successive alarms, you might adjust the Peak Power value through the Alarm Information screen or Setup menu.
+S Time Limit	The actual time value exceeded the plus suspect time limit.	Inspect your parts. For numerous or successive alarms, you might adjust the Time value through the Alarm Information screen or Setup menu or change suspect time limits.
+S Trg Dist Limit	The actual trigger distance value exceeded the plus suspect trigger distance limit.	Inspect your parts. For numerous or successive alarms, you might adjust the Trigger Distance Limit through the Alarm Information screen or Setup menu.
+R Abs Dist Limit	The absolute distance used in the most recent weld was greater than the upper reject limit you set.	Discard the part. If you encounter numerous or successive alarms with good parts, you might change your reject absolute distance limit.
+R Abs Dist Limit	The absolute distance used in the most recent weld was greater than the upper reject limit you set.	Discard the part. If you encounter numerous or successive alarms with good parts, you might change your reject absolute distance limit.
+S Abs Dist Limit	The absolute distance used in the most recent weld was greater than the upper suspect limit you set.	Manually inspect the part for a good weld. If you encounter numerous or successive alarms with good parts, you might change your suspect absolute distance limits.
- R Abs Dist Limit	The absolute distance used in the most recent weld was less than the lower reject limit you set.	Discard the part. If you encounter numerous or successive alarms with good parts, you might change your reject absolute distance limit.

**Table 7.9** Suspect/Reject Alarms and Messages, with Probable Cause and Corrective Action

Display Message	Alarm Condition/Cause	Corrective Action
- S Abs Dist Limit	The absolute distance used in the most recent weld was less than the lower suspect limit you set.	Manually inspect the part for a good weld. If you encounter numerous or successive alarms with good parts, you might change your suspect absolute distance limits.
+R Energy Limit	The energy used in the most recent weld was greater than the upper reject limit you set.	Discard the part. If you encounter numerous or successive alarms with good parts, you might change your reject energy limits.
+S Energy Limit	The energy used in the most recent weld was greater than the upper suspect limit you set.	Manually inspect the part for a good weld. If you encounter numerous or successive alarms with good parts, you might change your suspect energy limits.
Energy Not Reached	The weld time has been extended up to 50% and the minimum energy has still not been reached.	Discard the part. If you encounter numerous or successive alarms with good parts, you might change your minimum energy setting.
- R Energy Limit	The energy used in the most recent weld was less than the lower reject limit you set.	Discard the part. If you encounter numerous or successive alarms with good parts, you might change your reject energy limits.
- S Energy Limit	The energy used in the most recent weld was less than the lower suspect limit you set.	Manually inspect the part for a good weld. If you encounter numerous or successive alarms with good parts, you might change your suspect energy limits.
+ R Pk Power Limit	The peak power used in the most recent weld was greater than the upper reject limit you set.	Discard the part. If you encounter numerous or successive alarms with good parts, you might change your reject peak power limits.
+S Pk Power Limit	The peak power used in the most recent weld was greater than the upper suspect limit you set.	Manually inspect the part for a good weld. If you encounter numerous or successive alarms with good parts, you might change your suspect peak power limits.

**Table 7.9** Suspect/Reject Alarms and Messages, with Probable Cause and Corrective Action

<b>Display Message</b>	<b>Alarm Condition/Cause</b>	<b>Corrective Action</b>
- R Pk Power Limit	The peak power used in the most recent weld was less than the lower reject limit you set.	Discard the part. If you encounter numerous or successive alarms with good parts, you might change your reject peak power limits.
- S Pk Power Limit	The peak power used in the most recent weld was less than the lower suspect limit you set.	Manually inspect the part for a good weld. If you encounter numerous or successive alarms with good parts, you might change your suspect peak power limits.
- R Abs Dist Limit	The actual distance value did not reach the minus reject absolute distance limit.	Discard the part if you encounter numerous or successive alarms with good parts. Consider changing your Absolute settings.
- R Col Dist Limit	The collapse distance used in the most recent weld was less than the lower reject limit you set.	Discard the part. If you encounter numerous or successive alarms with good parts, you might change your reject collapse distance limits.
+ R Col Dist Limit	The collapse distance used in the most recent weld was greater than the upper reject limit you set.	Discard the part. If you encounter numerous or successive alarms with good parts, you might change your reject collapse distance limits.
+ S Col Dist Limit	The collapse distance used in the most recent weld was greater than the upper suspect limit you set.	Manually inspect the part for a good weld. If you encounter numerous or successive alarms with good parts, you might change your suspect collapse distance limits.
+ S Trg Dist Limit	The trigger distance used in the most recent weld was greater than the upper suspect limit you set.	Manually inspect the part for a good weld. If you encounter numerous or successive alarms with good parts, you might change your suspect trigger distance limits.
+R Abs Dist Limit	The actual distance value exceeded the plus reject absolute distance limit.	Discard the part if you encounter numerous or successive alarms with good parts. Consider changing your Absolute settings.

**Table 7.9** Suspect/Reject Alarms and Messages, with Probable Cause and Corrective Action

Display Message	Alarm Condition/Cause	Corrective Action
+R Energy Limit	The actual energy value exceeded the plus reject energy limit.	Discard the part if you encounter numerous or successive alarms with good parts. Consider changing your Energy settings.
+R Weld Force Limit	The actual Weld Force exceeded the plus Reject Weld Force limit.	Discard the part if you encounter numerous or successive alarms with good parts. Consider changing your Weld Force settings.
+R Pk Power Limit	The actual peak power value exceeded the plus reject peak power limit.	Discard the part if you encounter numerous or successive alarms with good parts. Consider changing your Peak Power settings.
+R Time Limit	The actual time value exceeded the plus reject time limit.	Discard the part if you encounter numerous or successive alarms with good parts. Consider changing your Time settings or your reject time limits.
+R Trg Dist Limit	The actual trigger distance value exceeded the plus reject trigger distance limit.	Adjust + reject trigger distance limit through the Alarm Information screen or Setup menu. Discard the part if you encounter numerous or successive alarms.
+R Weld Force Limit	Actual Weld Force did not reach minus reject Weld Force limit.	Adjust +reject weld force through the Alarm Information screen or Setup menu. Discard the part if you encounter numerous or successive alarms.
+S Abs Dist Limit	The actual absolute distance value did not reach the plus suspect absolute distance limit.	Inspect your parts. For numerous or successive alarms, you might adjust +suspect trigger distance limit through the Alarm Information screen or Setup menu.
+S Col Dist Limit	The actual collapse distance value exceeded the plus suspect collapse distance limit.	Inspect your parts. For numerous or successive alarms, you might adjust the collapse distance value through the Alarm Information screen or Setup menu.

**Table 7.9** Suspect/Reject Alarms and Messages, with Probable Cause and Corrective Action

Display Message	Alarm Condition/Cause	Corrective Action
+S Energy Limit	The actual energy value exceeded the plus suspect energy limit.	Inspect your parts. For numerous or successive alarms, you might adjust the Energy value through the Alarm Information screen or Setup menu.
+S Weld Force Limit	The actual Weld Force exceeded the plus suspect Weld Force limit.	Inspect your parts. For numerous or successive alarms, you might adjust the Weld Force value through the Alarm Information screen or Setup menu.
+S Pk Power Limit	The actual peak power value exceeded the plus suspect peak power limit.	Inspect your parts. For numerous or successive alarms, you might adjust the Peak Power value through the Alarm Information screen or Setup menu.
+S Time Limit	The actual time value exceeded the plus suspect time limit.	Inspect your parts. For numerous or successive alarms, you might adjust the Time value through the Alarm Information screen or Setup menu or change suspect time limits.
+S Trg Dist Limit	The actual trigger distance value exceeded the plus suspect trigger distance limit.	Inspect your parts. For numerous or successive alarms, you might adjust the Trigger Distance Limit through the Alarm Information screen or Setup menu.
+R Abs Dist Limit	The absolute distance used in the most recent weld was greater than the upper reject limit you set.	Discard the part. If you encounter numerous or successive alarms with good parts, you might change your reject absolute distance limit.
+R Abs Dist Limit	The absolute distance used in the most recent weld was greater than the upper reject limit you set.	Discard the part. If you encounter numerous or successive alarms with good parts, you might change your reject absolute distance limit.

**Table 7.9** Suspect/Reject Alarms and Messages, with Probable Cause and Corrective Action

Display Message	Alarm Condition/Cause	Corrective Action
+S Abs Dist Limit	The absolute distance used in the most recent weld was greater than the upper suspect limit you set.	Manually inspect the part for a good weld. If you encounter numerous or successive alarms with good parts, you might change your suspect absolute distance limits.
- R Abs Dist Limit	The absolute distance used in the most recent weld was less than the lower reject limit you set.	Discard the part. If you encounter numerous or successive alarms with good parts, you might change your reject absolute distance limit.
- S Abs Dist Limit	The absolute distance used in the most recent weld was less than the lower suspect limit you set.	Manually inspect the part for a good weld. If you encounter numerous or successive alarms with good parts, you might change your suspect absolute distance limits.
+R Energy Limit	The energy used in the most recent weld was greater than the upper reject limit you set.	Discard the part. If you encounter numerous or successive alarms with good parts, you might change your reject energy limits.
+S Energy Limit	The energy used in the most recent weld was greater than the upper suspect limit you set.	Manually inspect the part for a good weld. If you encounter numerous or successive alarms with good parts, you might change your suspect energy limits.
Energy Not Reached	The weld time has been extended up to 50% and the minimum energy has still not been reached.	Discard the part. If you encounter numerous or successive alarms with good parts, you might change your minimum energy setting.
- R Energy Limit	The energy used in the most recent weld was less than the lower reject limit you set.	Discard the part. If you encounter numerous or successive alarms with good parts, you might change your reject energy limits.
- S Energy Limit	The energy used in the most recent weld was less than the lower suspect limit you set.	Manually inspect the part for a good weld. If you encounter numerous or successive alarms with good parts, you might change your suspect energy limits.

**Table 7.9** Suspect/Reject Alarms and Messages, with Probable Cause and Corrective Action

<b>Display Message</b>	<b>Alarm Condition/Cause</b>	<b>Corrective Action</b>
+ R Pk Power Limit	The peak power used in the most recent weld was greater than the upper reject limit you set.	Discard the part. If you encounter numerous or successive alarms with good parts, you might change your reject peak power limits.
+S Pk Power Limit	The peak power used in the most recent weld was greater than the upper suspect limit you set.	Manually inspect the part for a good weld. If you encounter numerous or successive alarms with good parts, you might change your suspect peak power limits.
- R Pk Power Limit	The peak power used in the most recent weld was less than the lower reject limit you set.	Discard the part. If you encounter numerous or successive alarms with good parts, you might change your reject peak power limits.
- S Pk Power Limit	The peak power used in the most recent weld was less than the lower suspect limit you set.	Manually inspect the part for a good weld. If you encounter numerous or successive alarms with good parts, you might change your suspect peak power limits.
- R Abs Dist Limit	The actual distance value did not reach the minus reject absolute distance limit.	Discard the part if you encounter numerous or successive alarms with good parts. Consider changing your Absolute settings.
- R Col Dist Limit	The collapse distance used in the most recent weld was less than the lower reject limit you set.	Discard the part. If you encounter numerous or successive alarms with good parts, you might change your reject collapse distance limits.
-R Freq Limit	The system Bandwidth Limit (SBL) function has determined the frequency has dropped too much and is now close to the series resonant point.	Verify integrity of stack. Review application.
+R Freq Limit	The system Bandwidth Limit (SBL) function has determined the frequency has risen too much and is now close to the series resonant point.	Verify integrity of stack. Review application.

**Table 7.9** Suspect/Reject Alarms and Messages, with Probable Cause and Corrective Action

<b>Display Message</b>	<b>Alarm Condition/Cause</b>	<b>Corrective Action</b>
-R PMC Band Limit	The Power Match Curve function has detected points below the acceptable curve.	Run additional cycles to determine if this is a trend or an anomaly. Examine process and adjust accordingly.
+R PMC Band Limit	The Power Match Curve function has detected points above the acceptable curve.	Run additional cycles to determine if this is a trend or an anomaly. Examine process and adjust accordingly.
- R Weld Force Limit	The actual Weld Force did not reach the minus reject Weld Force limit.	Adjust - reject weld force through the Alarm Information screen or Setup menu. Discard the part if you encounter numerous or successive alarms.
- R Time Limit	The actual time value did not reach the minus reject time limit.	Discard the part if you encounter numerous or successive alarms with good parts. Consider changing your Time settings.
- R Weld Force Limit	The actual Weld Force did not reach the minus reject Weld Force limit.	Adjust - reject weld force through the Alarm Information screen or Setup menu. Discard the part if you encounter numerous or successive alarms.
- R Time Limit	The actual time value did not reach the minus reject time limit.	Discard the part if you encounter numerous or successive alarms with good parts. Consider changing your Time settings.

## 7.5.6 Setup Alarms and Messages

**Table 7.10** Setup Alarms and Messages, with Probable Cause and Corrective Action

<b>Display Message</b>	<b>Alarm Condition/Cause</b>	<b>Corrective Action</b>
Amp Step Conflict	The distance you have set for the amplitude to step is equal to or greater than the absolute distance you have set.	Change the step distance for the amplitude and/or the absolute distance settings.

**Table 7.10** Setup Alarms and Messages, with Probable Cause and Corrective Action

<b>Display Message</b>	<b>Alarm Condition/Cause</b>	<b>Corrective Action</b>
Amp Step Conflict	The energy level you have set for the amplitude to step is in conflict with the energy level you have set for the weld cycle.	Change the step energy for the amplitude and/or the energy level for the weld cycle.
Amp Step Conflict	The time that you have set for the amplitude to step is greater than the time that you have set for the weld cycle.	Change the step time for the amplitude and/or the time setting for the weld cycle.
Amp Step Conflict	The amplitude step value is equal to or greater than the plus reject peak power limit value.	Change the amplitude step or +reject peak power limit through the Alarm Information screen or Setup menu.
Amp Step Conflict	The amplitude step value is equal to or greater than the plus suspect peak power limit.	Change the amplitude step or +suspect peak power limit through the Alarm Information screen or Setup menu.
Amp Step Conflict	The amplitude step value is equal to or greater than the plus reject energy limit.	Change the amplitude step or +reject energy limit through the Alarm Information screen or Setup menu.
Amp Step Conflict	The amplitude step value is equal to or greater than the plus suspect energy limit.	Change the amplitude step or +suspect energy limit through the Alarm Information screen or Setup menu.
Amp Step Conflict	The amplitude step at power value is equal to or greater than the peak power value. This alarm is for peak power mode only.	Change the amplitude step or peak power main parameter through the Alarm Information screen or Setup menu.
Amp Step Conflict	The amplitude step at energy value is equal to or greater than the max energy compensation value.	Change the amplitude step or maximum energy compensation limit through the Alarm Information screen or Setup menu.
Amp Step Conflict	The amplitude step value is equal to or greater than the peak power cutoff value. This alarm is in all modes but peak power.	Change the amplitude step or peak power cutoff through the Alarm Information screen or Setup menu.
Amp Step Conflict	The amplitude step at time value is equal to or greater than the maximum timeout value. This occurs in all modes except time.	Change the amplitude step at time value and/or the maximum timeout value through the Alarm Information screen or Setup menu.

**Table 7.10** Setup Alarms and Messages, with Probable Cause and Corrective Action

<b>Display Message</b>	<b>Alarm Condition/Cause</b>	<b>Corrective Action</b>
Cutoff Conflict	The minus reject power limit is equal to or greater than the peak power cutoff value.	Change the - reject power limit or peak power cutoff through the Alarm Information screen or Setup menu.
Cutoff Conflict	The plus reject power limit is equal to or greater than the peak power cutoff value.	Change the +reject power limit or peak power cutoff through the Alarm Information screen or Setup menu.
Cutoff Conflict	The minus suspect power limit is equal to or greater than the peak power cutoff value.	Change the - suspect power limit or peak power cutoff through the Alarm Information screen or Setup menu.
Cutoff Conflict	The plus suspect power limit is equal to or less than the peak power cutoff value.	Change the +suspect power limit or peak power cutoff through the Alarm Information screen or Setup menu.
Energy Comp Conflict	The plus reject energy limit is equal to or less than the minimum energy compensation value. This alarm occurs in time mode only.	Change the +Reject energy limit or minimum energy compensation through the Alarm Information screen or Setup menu.
Energy Comp Conflict	The plus suspect energy limit is equal to or less than the minimum energy compensation value. This alarm occurs in time mode only.	Change the +Suspect energy limit or minimum energy compensation through the Alarm Information screen or Setup menu.
Energy Comp Conflict	The minus reject energy limit is equal to or less than the maximum energy compensation value. This alarm occurs in time mode only.	Change the - Reject energy limit or maximum energy compensation through the Alarm Information screen or Setup menu.
Energy Comp Conflict	The minus suspect energy limit is equal to or less than the maximum energy compensation value. This alarm occurs in time mode only.	Change the - Suspect energy limit or maximum energy compensation through the Alarm Information screen or Setup menu.
Energy Comp Conflict	The minus reject energy limit is equal to or less than the minimum energy compensation value.	Change the - Reject energy limit or minimum energy compensation through the Alarm Information screen or Setup menu.
Energy Comp Conflict	The minus suspect energy limit is equal to or less than the minimum energy compensation value.	Change the - Suspect energy limit or energy compensation through the Alarm Information screen or Setup menu.

**Table 7.10** Setup Alarms and Messages, with Probable Cause and Corrective Action

<b>Display Message</b>	<b>Alarm Condition/Cause</b>	<b>Corrective Action</b>
Energy Comp Conflict	The plus energy reject limit is equal to or greater than the energy compensation maximum value	Change the +Reject energy limit or maximum energy compensation through the Alarm Information screen or Setup menu.
Energy Comp Conflict	The plus suspect energy limit is equal to or greater than the energy compensation maximum value.	Change the +Suspect energy limit or maximum energy compensation through the Alarm Information screen or Setup menu.
Energy Comp Crossed	The energy minimum and maximum settings are crossed. This alarm is only valid when energy compensation is on.	Change the minimum and maximum energy compensation limits through the Alarm Information screen or Setup menu.
+- Eng Limit Crossed	The suspect limits for energy that you have entered are reversed.	Change the suspect energy limits through the Alarm Information screen or Setup menu.
+- Eng Limit Crossed	The reject limits for energy that you have entered are reversed.	Change the reject energy limits through the Alarm Information screen or Setup menu.
Eng S/R Limit Cross	The plus reject energy limit is equal to or less than the minus suspect energy limit.	Change the +reject energy limit or - suspect energy limit through the Alarm Information screen or Setup menu.
Eng S/R Limit Cross	The plus suspect energy limit is equal to or less than the minus reject energy limit.	Change the +suspect energy limit or - reject energy limit through the Alarm Information screen or Setup menu.
Eng S/R Limit Cross	The plus reject energy limit is equal to or less than the plus suspect energy limit.	Change the +reject energy limit or +suspect energy limit through the Alarm Information screen or Setup menu.
Eng S/R Limit Cross	The minus reject energy limit is equal to or greater than the minus suspect energy limit.	Change the - reject energy limit or - suspect energy limit through the Alarm Information screen or Setup menu.
Amp Step Conflict	The distance you have set for the amplitude to step is equal to or greater than the absolute distance you have set.	Change the step distance for the amplitude and/or the absolute distance settings.

**Table 7.10** Setup Alarms and Messages, with Probable Cause and Corrective Action

<b>Display Message</b>	<b>Alarm Condition/Cause</b>	<b>Corrective Action</b>
Amp Step Conflict	The energy level you have set for the amplitude to step is in conflict with the energy level you have set for the weld cycle.	Change the step energy for the amplitude and/or the energy level for the weld cycle.
Amp Step Conflict	The time that you have set for the amplitude to step is greater than the time that you have set for the weld cycle.	Change the step time for the amplitude and/or the time setting for the weld cycle.
Amp Step Conflict	The amplitude step value is equal to or greater than the plus reject peak power limit value.	Change the amplitude step or +reject peak power limit through the Alarm Information screen or Setup menu.
Amp Step Conflict	The amplitude step value is equal to or greater than the plus suspect peak power limit.	Change the amplitude step or +suspect peak power limit through the Alarm Information screen or Setup menu.
Amp Step Conflict	The amplitude step value is equal to or greater than the plus reject energy limit.	Change the amplitude step or +reject energy limit through the Alarm Information screen or Setup menu.
Amp Step Conflict	The amplitude step value is equal to or greater than the plus suspect energy limit.	Change the amplitude step or +suspect energy limit through the Alarm Information screen or Setup menu.
Amp Step Conflict	The amplitude step at power value is equal to or greater than the peak power value. This alarm is for peak power mode only.	Change the amplitude step or peak power main parameter through the Alarm Information screen or Setup menu.
Amp Step Conflict	The amplitude step at energy value is equal to or greater than the max energy compensation value.	Change the amplitude step or maximum energy compensation limit through the Alarm Information screen or Setup menu.
Amp Step Conflict	The amplitude step value is equal to or greater than the peak power cutoff value. This alarm is in all modes but peak power.	Change the amplitude step or peak power cutoff through the Alarm Information screen or Setup menu.
Amp Step Conflict	The amplitude step at time value is equal to or greater than the maximum timeout value. This occurs in all modes except time.	Change the amplitude step at time value and/or the maximum timeout value through the Alarm Information screen or Setup menu.

**Table 7.10** Setup Alarms and Messages, with Probable Cause and Corrective Action

<b>Display Message</b>	<b>Alarm Condition/Cause</b>	<b>Corrective Action</b>
Cutoff Conflict	The minus reject power limit is equal to or greater than the peak power cutoff value.	Change the - reject power limit or peak power cutoff through the Alarm Information screen or Setup menu.
Cutoff Conflict	The plus reject power limit is equal to or greater than the peak power cutoff value.	Change the +reject power limit or peak power cutoff through the Alarm Information screen or Setup menu.
Cutoff Conflict	The minus suspect power limit is equal to or greater than the peak power cutoff value.	Change the - suspect power limit or peak power cutoff through the Alarm Information screen or Setup menu.
Cutoff Conflict	The plus suspect power limit is equal to or less than the peak power cutoff value.	Change the +suspect power limit or peak power cutoff through the Alarm Information screen or Setup menu.
Energy Comp Conflict	The plus reject energy limit is equal to or less than the minimum energy compensation value. This alarm occurs in time mode only.	Change the +Reject energy limit or minimum energy compensation through the Alarm Information screen or Setup menu.
Energy Comp Conflict	The plus suspect energy limit is equal to or less than the minimum energy compensation value. This alarm occurs in time mode only.	Change the +Suspect energy limit or minimum energy compensation through the Alarm Information screen or Setup menu.
Energy Comp Conflict	The minus reject energy limit is equal to or less than the maximum energy compensation value. This alarm occurs in time mode only.	Change the - Reject energy limit or maximum energy compensation through the Alarm Information screen or Setup menu.
Energy Comp Conflict	The minus suspect energy limit is equal to or less than the maximum energy compensation value. This alarm occurs in time mode only.	Change the - Suspect energy limit or maximum energy compensation through the Alarm Information screen or Setup menu.
Energy Comp Conflict	The minus reject energy limit is equal to or less than the minimum energy compensation value.	Change the - Reject energy limit or minimum energy compensation through the Alarm Information screen or Setup menu.
Energy Comp Conflict	The minus suspect energy limit is equal to or less than the minimum energy compensation value.	Change the - Suspect energy limit or energy compensation through the Alarm Information screen or Setup menu.

**Table 7.10** Setup Alarms and Messages, with Probable Cause and Corrective Action

<b>Display Message</b>	<b>Alarm Condition/Cause</b>	<b>Corrective Action</b>
Energy Comp Conflict	The plus energy reject limit is equal to or greater than the energy compensation maximum value	Change the +Reject energy limit or maximum energy compensation through the Alarm Information screen or Setup menu.
Energy Comp Conflict	The plus suspect energy limit is equal to or greater than the energy compensation maximum value.	Change the +Suspect energy limit or maximum energy compensation through the Alarm Information screen or Setup menu.
Energy Comp Crossed	The energy minimum and maximum settings are crossed. This alarm is only valid when energy compensation is on.	Change the minimum and maximum energy compensation limits through the Alarm Information screen or Setup menu.
+ - Eng Limit Crossed	The suspect limits for energy that you have entered are reversed.	Change the suspect energy limits through the Alarm Information screen or Setup menu.
+ - Eng Limit Crossed	The reject limits for energy that you have entered are reversed.	Change the reject energy limits through the Alarm Information screen or Setup menu.
Eng S/R Limit Cross	The plus reject energy limit is equal to or less than the minus suspect energy limit.	Change the +reject energy limit or - suspect energy limit through the Alarm Information screen or Setup menu.
Eng S/R Limit Cross	The plus suspect energy limit is equal to or less than the minus reject energy limit.	Change the +suspect energy limit or - reject energy limit through the Alarm Information screen or Setup menu.
Eng S/R Limit Cross	The plus reject energy limit is equal to or less than the plus suspect energy limit.	Change the +reject energy limit or +suspect energy limit through the Alarm Information screen or Setup menu.
Eng S/R Limit Cross	The minus reject energy limit is equal to or greater than the minus suspect energy limit.	Change the - reject energy limit or - suspect energy limit through the Alarm Information screen or Setup menu.
Force A > Pressure	A force value was selected while the set pressure was 80 psi, then the set pressure was reduced to 60 psi.	A new force value must be entered.
Force B > Pressure	The force value was selected while the set pressure was 80 psi, then the set pressure was changed to 60 psi.	The force value must be re-entered.

**Table 7.10** Setup Alarms and Messages, with Probable Cause and Corrective Action

<b>Display Message</b>	<b>Alarm Condition/Cause</b>	<b>Corrective Action</b>
Force/Lmt Conflict	Weld force is equal to or greater than the plus reject weld force limit. This alarm can only occur if force stepping is off.	Either raise the reject limit or lower the weld force.
Force/Lmt Conflict	Weld force is equal to or greater than the plus suspect weld force limit. This alarm can only occur if force stepping is off.	Either raise the suspect limit or lower the weld force.
Force/Lmt Conflict	Weld force is equal to or less than the minus reject weld force limit. This alarm can only occur if force stepping is off.	Either raise the reject limit or lower the weld force.
Force/Lmt Conflict	Weld force is equal to or less than the minus suspect weld force limit. This alarm can only occur if force stepping is off.	Either raise the suspect limit or lower the weld force.
Force/Lmt Conflict	Force B is equal to or greater than the plus reject weld force limit. This alarm can only occur if force stepping is on.	Either raise the reject limit or lower the force B setting.
Force/Lmt Conflict	Force B is equal to or greater than the plus suspect weld force limit. This alarm can only occur if force stepping is on.	Either raise the suspect limit or lower the force B settings.
Force/Lmt Conflict	Force B is equal to or less than the minus reject weld force limit. This alarm can only occur if force stepping is on.	Either lower the reject limit or raise force B setting.
Force/Lmt Conflict	Force B is equal to or less than the minus suspect weld force limit. This alarm can only occur if force stepping is on.	Either lower the suspect limit or raise the force B setting.
Force Step Conflict	The force step at power is equal to or greater than the plus reject peak power limit. This alarm cannot occur in peak power welding mode.	Either raise the reject limit or lower the step at power setting.
Force Step Conflict	The force step at power is equal to or greater than the plus suspect peak power limit. This alarm cannot occur in peak power welding mode.	Either raise the suspect limit or lower the step at power setting.
Force Step Conflict	The force step at energy is equal to or greater than the plus reject energy limit. This alarm cannot occur in energy welding mode.	Either raise the reject limit or lower the step at energy setting.

**Table 7.10** Setup Alarms and Messages, with Probable Cause and Corrective Action

<b>Display Message</b>	<b>Alarm Condition/Cause</b>	<b>Corrective Action</b>
Force Step Conflict	The force step at energy is equal to or greater than the plus suspect energy limit. This alarm cannot occur in energy welding mode.	Either raise the suspect limit or lower the step at energy setting.
Force Step Conflict	The force step at distance is equal to or less than the minus reject collapse limit. This alarm cannot occur in collapse welding mode.	Either lower reject limit or raise the step at distance setting.
Force Step Conflict	The force step at distance is equal to or less than the minus suspect collapse limit. This alarm cannot occur in collapse welding mode.	Either lower the suspect limit or raise the step at distance setting.
Force Step Conflict	The force step at energy is equal to or greater than the plus suspect energy limit. This alarm cannot occur in energy welding mode.	Either raise the suspect limit or the step at energy setting.
Force Step Conflict	The force step at collapse distance is equal to or greater than the plus reject collapse limit. This alarm cannot occur in collapse welding mode.	Either raise the reject limit or lower the step at collapse setting.
Force Step Conflict	The force step at distance is equal to or greater than the plus suspect collapse limit. This alarm cannot occur in collapse welding mode.	Either raise the suspect limit or lower the step at distance setting.
Force Step Conflict	The force step at peak power is equal to or greater than the peak power cutoff value. This alarm can occur in all modes except peak power.	Either raise the peak power cutoff or lower the step at power setting.
Force Step Conflict	The force step at peak power is equal to or greater than the peak power setting. This alarm cannot occur in peak power mode only.	Either raise the peak power setting or lower the step at peak power setting.
Force Step Conflict	The force step at energy is equal to or greater than the energy setting. This alarm cannot occur in energy mode only.	Either raise the energy setting or lower the step at energy value.
Force Step Conflict	The force step at energy is equal to or greater than the maximum energy compensation setting. This alarm will occur in time mode with the energy compensation on only.	Either raise max energy compensation or lower the step at energy setting.

**Table 7.10** Setup Alarms and Messages, with Probable Cause and Corrective Action

Display Message	Alarm Condition/Cause	Corrective Action
Force Step Conflict	The force step at time is equal to or greater than the maximum weld time. This alarm can occur in all weld modes except time.	Either increase the max weld time or lower the step at time setting.
Force Step Cutoff	The collapse cutoff distance is equal to or less than the step at collapse distance. This alarm can occur in all welding modes except collapse.	Either decrease the step at collapse distance or increase the collapse cutoff distance.
Hold Force > Pressure	The hold force was entered when the set pressure was 80 psi. The pressure was then reduced to 60 psi. Therefor this force can no longer be reached.	Re-enter the hold force value or go into horndown and increase the pressure to 80 psi.
No Force Step	The force step at time value was not reached.	Manually inspect the part. If the part is acceptable, turn force stepping off. If the part is not acceptable, you might want to adjust your main parameter.
No Force Step	The force step at energy value was not reached.	Manually inspect the part. If the part is acceptable, turn force stepping off. If the part is not acceptable, you might want to adjust your main parameter.
No Force Step	The force step at power was not reached.	Manually inspect the part. If the part is acceptable, turn force stepping off. If the part is not acceptable, you might want to adjust your main parameter.
No Force Step	The force step at external signal input not received.	Manually inspect the part. If the part is acceptable, turn force stepping off. If the part is not acceptable, you might want to adjust your main parameter.
No Force Step	The collapse distance required for the force step not reached.	Manually inspect the part. If the part is acceptable, turn force stepping off. If the part is not acceptable, you might want to adjust your main parameter.
Preset Not Available	Preset is recalled via external inputs and the preset is not defined or is not allowed for the control level.	Check control level availability for preset. Preset is not defined. Make sure presets do not exceed 16.

**Table 7.10** Setup Alarms and Messages, with Probable Cause and Corrective Action

<b>Display Message</b>	<b>Alarm Condition/Cause</b>	<b>Corrective Action</b>
Pressure > Weld Force	The weld force cannot be reached because the set pressure is too high.	
+ - Pwr Limit Crossed	The suspect limits for power that you have entered are reversed.	Change the suspect power limits through the Alarm Information screen or Setup menu.
+ - Pwr Limit Crossed	The reject limits for power that you have entered are reversed.	Change the reject power limits through the Alarm Information screen or Setup menu.
Pwr S/R Limit Cross	The plus reject power limit is equal to or less than the minus suspect power limit.	Change the +reject power limit or - suspect power limit through the Alarm Information screen or Setup menu.
Pwr S/R Limit Cross	The plus reject power limit is equal to or less than the plus suspect power limit.	Change the +reject power limit or +suspect power limit through the Alarm Information screen or Setup menu.
Pwr S/R Limit Cross	The plus suspect power limit is equal to or less than the minus reject power limit.	Change the +suspect power limit or - reject power limit through the Alarm Information screen or Setup menu.
Pwr S/R Limit Cross	The minus reject power limit is equal to or greater than the minus suspect power limit.	Change the - reject power limit or - suspect power limit through the Alarm Information screen or Setup menu.
+ - Pwr Limit Crossed	The suspect limits for power that you have entered are reversed.	Change the suspect power limits through the Alarm Information screen or Setup menu.
+ - Pwr Limit Crossed	The reject limits for power that you have entered are reversed.	Change the reject power limits through the Alarm Information screen or Setup menu.
Pwr S/R Limit Cross	The plus reject power limit is equal to or less than the minus suspect power limit.	Change the +reject power limit or - suspect power limit through the Alarm Information screen or Setup menu.
Pwr S/R Limit Cross	The plus reject power limit is equal to or less than the plus suspect power limit.	Change the +reject power limit or +suspect power limit through the Alarm Information screen or Setup menu.

**Table 7.10** Setup Alarms and Messages, with Probable Cause and Corrective Action

Display Message	Alarm Condition/Cause	Corrective Action
Pwr S/R Limit Cross	The plus suspect power limit is equal to or less than the minus reject power limit.	Change the +suspect power limit or - reject power limit through the Alarm Information screen or Setup menu.
Pwr S/R Limit Cross	The minus reject power limit is equal to or greater than the minus suspect power limit.	Change the - reject power limit or - suspect power limit through the Alarm Information screen or Setup menu.
Rapid Trav. Conflict	The rapid traverse distance is equal to or greater than the minus reject absolute limit.	Either increase the reject distance limit or decrease the rapid traverse distance.
Rapid Trav. Conflict	The rapid traverse distance is equal to or greater than the minus suspect absolute limit.	Either increase the suspect distance limit or decrease the rapid traverse distance.
Rapid Trav. Conflict	The rapid traverse distance is equal to or greater than the plus reject absolute limit.	Either increase the reject distance limit or decrease the rapid traverse distance.
Rapid Trav. Conflict	The rapid traverse distance is equal to or greater than the plus suspect absolute limit.	Either increase the suspect distance limit or decrease the rapid traverse distance.
Rapid Trav. Conflict	The rapid traverse distance is equal to or greater than the plus reject trigger limit.	Either increase the reject distance limit or decrease the rapid traverse distance.
Rapid Trav. Conflict	The rapid traverse distance is equal to or greater than the plus suspect trigger limit.	Either increase the suspect distance limit or decrease the rapid traverse distance.
Rapid Trav. Conflict	The rapid traverse distance is equal to or greater than the minus reject trigger limit.	Either increase the reject distance limit or decrease the rapid traverse distance.
Rapid Trav. Conflict	The rapid traverse distance is equal to or greater than the minus suspect trigger limit.	Either increase the suspect distance limit or decrease the rapid traverse distance.
Rapid Trav. Conflict	The rapid traverse distance is equal to or greater than the absolute distance cutoff. This alarm can occur in all weld modes except absolute.	Either increase the absolute cutoff distance or decrease the rapid traverse distance.
Rapid Trav. Conflict	The rapid traverse distance is equal to or greater than the absolute distance. This alarm can occur only in the absolute welding mode.	Either increase the absolute cutoff distance or decrease the rapid traverse distance.
Sync Setup	The sync input pin and the sync output pin are not both defined.	Define missing sync pin.

**Table 7.10** Setup Alarms and Messages, with Probable Cause and Corrective Action

<b>Display Message</b>	<b>Alarm Condition/Cause</b>	<b>Corrective Action</b>
Ext Signal	Ext Start requires both an input pin and an output pin to function. One of the pins is not defined.	Define both and input and an output pin for the SV Interlock.
Sync Setup	The sync input pin and the sync output pin are not both defined.	Define missing sync pin.
Sys. Pres. Incorrect	The system pressure is out of tolerance (+/-3 PSI). The pressure is read only after five seconds of idle time while in ready. This alarm does not remove the ready signal because that would prevent entry into horn down. Horndown is the only place where the pressure can be viewed for adjustment.	Go to horndown and adjust the system pressure to either 60 psi (+/- 3 psi) or 80 psi (+/- 3 psi).
+ - Time Limit Crossed	The suspect limits for time that you have entered are reversed.	Change the suspect time limits through the Alarm Information screen or Setup menu.
+ - Time Limit Crossed	The reject limits for time that you have entered are reversed.	Change the reject time limits through the Alarm Information screen or Setup menu.
Time S/R Limit Cross	The plus reject time limit is equal to or less than the minus suspect time limit.	Change the +reject time limit or - suspect time limit through the Alarm Information screen or Setup menu.
Time S/R Limit Cross	The plus suspect time is equal to or less than the minus reject time limit.	Change the +suspect time limit or - reject time limit through the Alarm Information screen or Setup menu.
Time S/R Limit Cross	The plus reject time limit is equal to or less than the plus suspect time limit.	Change the +reject time limit or +suspect time limit through the Alarm Information screen or Setup menu.
Time S/R Limit Cross	The minus reject time limit is equal to or greater than the minus suspect time limit.	Change the - reject time limit or - suspect time limit through the Alarm Information screen or Setup menu.
Timeout Conflict	The plus reject time limit is equal to or greater than the maximum timeout value.	Change the +reject time limit or maximum timeout value through the Alarm Information screen or Setup menu.
Timeout Conflict	The minus reject time limit is equal to or greater than the maximum timeout value.	Change the - reject time limit or maximum timeout value through the Alarm Information screen or Setup menu.

**Table 7.10** Setup Alarms and Messages, with Probable Cause and Corrective Action

<b>Display Message</b>	<b>Alarm Condition/Cause</b>	<b>Corrective Action</b>
Timeout Conflict	The plus suspect time limit is equal to or greater than the maximum timeout value.	Change the +suspect time limit or maximum timeout value through the Alarm Information screen or Setup menu.
Timeout Conflict	The minus suspect time limit is equal to or greater than the maximum timeout value.	Change the +suspect time limit or maximum timeout value through the Alarm Information screen or Setup menu.
+ - Time Limit Crossed	The suspect limits for time that you have entered are reversed.	Change the suspect time limits through the Alarm Information screen or Setup menu.
+ - Time Limit Crossed	The reject limits for time that you have entered are reversed.	Change the reject time limits through the Alarm Information screen or Setup menu.
Time S/R Limit Cross	The plus reject time limit is equal to or less than the minus suspect time limit.	Change the +reject time limit or - suspect time limit through the Alarm Information screen or Setup menu.
Time S/R Limit Cross	The plus suspect time is equal to or less than the minus reject time limit.	Change the +suspect time limit or - reject time limit through the Alarm Information screen or Setup menu.
Time S/R Limit Cross	The plus reject time limit is equal to or less than the plus suspect time limit.	Change the +reject time limit or +suspect time limit through the Alarm Information screen or Setup menu.
Time S/R Limit Cross	The minus reject time limit is equal to or greater than the minus suspect time limit.	Change the - reject time limit or - suspect time limit through the Alarm Information screen or Setup menu.
Timeout Conflict	The plus reject time limit is equal to or greater than the maximum timeout value.	Change the +reject time limit or maximum timeout value through the Alarm Information screen or Setup menu.
Timeout Conflict	The minus reject time limit is equal to or greater than the maximum timeout value.	Change the - reject time limit or maximum timeout value through the Alarm Information screen or Setup menu.
Timeout Conflict	The plus suspect time limit is equal to or greater than the maximum timeout value.	Change the +suspect time limit or maximum timeout value through the Alarm Information screen or Setup menu.

**Table 7.10** Setup Alarms and Messages, with Probable Cause and Corrective Action

<b>Display Message</b>	<b>Alarm Condition/Cause</b>	<b>Corrective Action</b>
Timeout Conflict	The minus suspect time limit is equal to or greater than the maximum timeout value.	Change the +suspect time limit or maximum timeout value through the Alarm Information screen or Setup menu.
Trigger Delay Conflict	External trigger delay has been enabled in weld setup, but no input pin has been defined.	Assign pin in System Configuration Menu.
Trigger Delay Conflict	External trigger delay and pretrigger are both on.	Turn one off.
Weld Force > pressure	The weld force was entered when the system pressure was 80 psi. The system pressure has been reduced to 60 psi and the requested force cannot be reached.	Re-enter the weld force value or go into horndown and increase the pressure to 80 psi.
Invalid Preset Error Code = 1	Features have been selected that are not valid for this control level. Includes things that could have been selected through host mode or selected by installing a BBR from a higher control level machine. Specific to Error code 1: MPS.	Currently, MPS is not available.
Invalid Preset Error Code = 2	Refer to text in first Invalid Preset entry. Specific to Error code 2: Amplitude stepping on Control Level 1 or 2.	Change the settings in your preset. A cold start may be needed.
Invalid Preset Error Code = 3	Refer to text in first Invalid Preset entry. Specific to Error code 3: Force stepping on Control Level 1, 2, 3 or 4.	Change the settings in your preset. A cold start may be needed.
Invalid Preset Error Code = 4	Refer to text in first Invalid Preset entry. Specific to Error code 4: Using a weld mode not valid for Control Level.	Change the settings in your preset. A cold start may be needed.
Invalid Preset Error Code = 5	Refer to text in first Invalid Preset entry. Specific to Error code 5: Invalid distance.	Change the settings in your preset. A cold start may be needed.
Invalid Preset Error Code = 6	Refer to text in first Invalid Preset entry. Specific to Error code 6: Invalid force.	Change the settings in your preset. A cold start may be needed.
Invalid Preset Error Code = 7	Refer to text in first Invalid Preset entry. Specific to Error code 7: Version incorrect.	Change the settings in your preset. A cold start may be needed.

**Table 7.10** Setup Alarms and Messages, with Probable Cause and Corrective Action

Display Message	Alarm Condition/Cause	Corrective Action
Invalid Preset Error Code = 8	Refer to text in first Invalid Preset entry. Specific to Error code 8: Control level or actuator incorrect.	Change the settings in your preset. A cold start may be needed.
Invalid Preset Error Code = 9	Refer to text in first Invalid Preset entry. Specific to Error code 9: No association of DUPS preset to the current COP preset.	Change the settings in your preset. A cold start may be needed.
Abs Cutoff Conflict	The absolute cutoff distance is equal to or less than the minus reject absolute limit.	Change the absolute cutoff distance or - reject absolute distance limit through the Alarm Information screen or Setup menu.
Abs Cutoff Conflict	The absolute cutoff distance is equal to or less than the minus reject trigger limit.	Change the absolute cutoff distance or - reject trigger distance limit through the Alarm Information screen or Setup menu.
Abs Cutoff Conflict	The absolute cutoff distance is equal to or less than the minus suspect absolute limit.	Change the absolute cutoff distance or - suspect absolute distance limit through the Alarm Information screen or Setup menu.
Abs Cutoff Conflict	The absolute cutoff distance is equal to or less than the minus suspect trigger limit.	Change the absolute cutoff distance or - suspect trigger distance limit through the Alarm Information screen or Setup menu.
Abs Cutoff Conflict	The absolute cutoff distance is equal to or less than the plus reject absolute limit.	Change the absolute cutoff distance or +reject absolute distance limit through the Alarm Information screen or Setup menu.
Abs Cutoff Conflict	The absolute cutoff distance is equal to or less than the plus reject trigger limit.	Change the absolute cutoff distance or +reject trigger distance limit through the Alarm Information screen or Setup menu.
Abs Cutoff Conflict	The absolute cutoff distance is equal to or less than the plus suspect absolute limit.	Change the absolute cutoff distance or +suspect absolute distance limit through the Alarm Information screen or Setup menu.

**Table 7.10** Setup Alarms and Messages, with Probable Cause and Corrective Action

<b>Display Message</b>	<b>Alarm Condition/Cause</b>	<b>Corrective Action</b>
Abs Cutoff Conflict	The absolute cutoff distance is equal to or less than the plus suspect trigger limit.	Change the absolute cutoff distance or +suspect trigger distance limit through the Alarm Information screen or Setup menu.
+ - Abs Limit Crossed	The suspect limits for absolute distance that you have entered are reversed.	Change the suspect absolute distance limits through the Alarm Information screen or Setup menu.
+ - Abs Limit Crossed	The reject limits for absolute distance that you have entered are reversed.	Change the reject absolute distance limits through the Alarm Information screen or Setup menu.
Abs S/R Limit Cross	The plus reject absolute distance limit is equal to or less than the minus suspect absolute distance limit.	Change the +reject absolute distance or - suspect absolute distance limit through the Alarm Information screen or Setup menu.
Abs S/R Limit Cross	The plus suspect absolute distance limit is equal to or less than the minus reject absolute distance limit.	Change the +suspect absolute distance or - reject absolute distance limit through the Alarm Information screen or Setup menu.
Abs S/R Limit Cross	The minus reject absolute distance limit is equal to or greater than the minus suspect absolute distance limit.	Change the - reject absolute distance limit or the - suspect absolute distance limit through the Alarm Information screen or Setup menu.
Abs S/R Limit Cross	The plus reject absolute distance limit is equal to or less than the plus suspect absolute distance limit.	Change the +reject absolute distance or +suspect absolute distance limit through the Alarm Information screen or Setup menu.
Amp Step Conflict	The amplitude step at collapse value is equal to or greater than the plus reject collapse limit.	Change the amplitude step or +reject collapse distance limit through the Alarm Information screen or Setup menu.
Amp Step Conflict	The amplitude step at collapse value is equal to or greater than the plus suspect collapse limit.	Change the amplitude step or +suspect collapse distance limit through the Alarm Information screen or Setup menu.

**Table 7.10** Setup Alarms and Messages, with Probable Cause and Corrective Action

Display Message	Alarm Condition/Cause	Corrective Action
Amp Step Conflict	The amplitude step at collapse value is equal to or greater than collapse cutoff.	Change the amplitude step or collapse cutoff through the Alarm Information screen or Setup menu.
Amp Step Conflict	The amplitude step at collapse distance is equal to or greater than the collapse distance.	Change the amplitude step or collapse distance through the Alarm Information screen or Setup menu.
+ - Col Limit Crossed	The suspect limits for collapse distance that you have entered are reversed.	Change the suspect collapse distance limits through the Alarm Information screen or Setup menu.
+ - Col Limit Crossed	The reject limits for collapse distance that you have entered are reversed.	Change the reject collapse distance limits through the Alarm Information screen or Setup menu
Col S/R Limit Cross	The plus reject collapse distance limit is equal to or less than the minus suspect collapse distance limit.	Change the +reject collapse distance limit or - suspect collapse distance limit through the Alarm Information screen or Setup menu.
Col S/R Limit Cross	The plus suspect collapse distance limit is equal to or less than the minus reject collapse distance limit.	Change the +suspect collapse distance limit or - reject collapse distance limit through the Alarm Information screen or Setup menu.
Col S/R Limit Cross	The plus reject collapse distance limit is equal to or less than the plus suspect collapse distance limit.	Change the +reject collapse distance limit or +suspect collapse distance limit through the Alarm Information screen or Setup menu.
Col S/R Limit Cross	The minus reject collapse distance limit is equal to or greater than the minus suspect collapse distance limit.	Change the -reject collapse distance limit or - suspect collapse distance limit through the Alarm Information screen or Setup menu.
Cutoff Conflict	The minus reject collapse limit is equal to or greater than the collapse cutoff value.	Change the -reject collapse limit or collapse cutoff through the Alarm Information screen or Setup menu.
Cutoff Conflict	The minus suspect collapse limit is equal to or greater than the collapse cutoff value.	Change the -suspect collapse limit or collapse cutoff through the Alarm Information screen or Setup menu.

**Table 7.10** Setup Alarms and Messages, with Probable Cause and Corrective Action

<b>Display Message</b>	<b>Alarm Condition/Cause</b>	<b>Corrective Action</b>
Cutoff Conflict	The minus reject absolute limit is equal to or greater than the absolute cutoff value.	Change the -Reject absolute limit or absolute cutoff through the Alarm Information screen or Setup menu.
Cutoff Conflict	The minus suspect absolute limit is equal to or greater than the absolute cutoff value.	Change the -Suspect absolute limit or absolute cutoff through the Alarm Information screen or Setup menu.
+ - F Limit Crossed	The minus reject weld force limit is equal to or greater than the plus reject weld force limit.	Change the -reject weld force limit and/or the +reject weld force limit through the Alarm Information screen or Setup menu.
+ - F Limit Crossed	The minus suspect force limit is equal to or greater than the plus suspect force limit.	Change the -suspect weld force limit and/or the +suspect weld force limit through the Alarm Information screen or Setup menu.
+ - F Limit Crossed	The + reject freq limit and - reject freq limit values are crossed.	Either make the correction or run a horn scan to automatically correct. This alarm is valid for VGA only.
F S/R Limit Cross	The plus reject force limit is equal to or less than the minus suspect force limit.	Change the +reject force limit and/or the -suspect force limit through the Alarm Information screen or Setup menu.
F S/R Limit Cross	The plus suspect force limit is equal to or less than the minus reject force limit.	Change the +suspect force limit and/or the -reject force limit through the Alarm Information screen or Setup menu.
F S/R Limit Cross	The plus reject force limit is equal to or less than the plus suspect force limit.	Change the +reject force limit and/or the +suspect force limit through the Alarm Information screen or Setup menu.
F S/R Limit Cross	The minus reject force limit is equal to or greater than the minus suspect force limit.	Change the -reject force limit and/or the - suspect force limit through the Alarm Information screen or Setup menu.
Min Trigger Conflict	The trigger force is set below the minimum allowable value.	Minimum trigger force is changed after the trigger force has been set, or if downloaded via host command.

**Table 7.10** Setup Alarms and Messages, with Probable Cause and Corrective Action

Display Message	Alarm Condition/Cause	Corrective Action
Missing Part Conflict	The missing part minimum is equal to or greater than the missing part maximum setting.	Change the missing part minimum and/or the missing part maximum setting through the Alarm Information screen or Setup menu.
Missing Part Conflict	The missing part maximum distance is equal to or less than the minus reject absolute limit.	Change the missing part maximum distance and/or the - reject absolute limit through the Alarm Information screen or Setup menu.
Missing Part Conflict	The missing part maximum distance is equal to or less than the minus reject absolute limit.	Change the missing part minimum limit or - reject absolute distance limit through the Alarm Information screen or Setup menu.
Missing Part Conflict	The missing part maximum distance is equal to or less than the minus reject trigger limit.	Change the missing part minimum limit or - reject trigger limit through the Alarm Information screen or Setup menu.
Missing Part Conflict	The missing part maximum distance is equal to or less than the minus reject trigger limit.	Change the missing part maximum distance or - reject trigger distance limit through the Alarm information screen or Setup menu.
Missing Part Conflict	The missing part maximum distance is equal to or less than the plus reject trigger limit.	Change the missing part maximum distance or +reject trigger distance limit through the Alarm information screen or Setup menu.
Missing Part Conflict	The missing part minimum distance is equal to or greater than the minus suspect absolute limit.	Change the missing part minimum distance limit or - suspect absolute distance limit through the Alarm Information screen or Setup menu.
Missing Part Conflict	The missing part maximum distance is equal to or less than the minus suspect trigger limit.	Change the missing part maximum distance limit or - suspect trigger limit through the Alarm Information screen or Setup menu.
Missing Part Conflict	The missing part minimum distance is equal to or greater than the minus suspect trigger limit.	Change the missing part minimum distance limit or - suspect trigger limit through the Alarm Information screen or Setup menu.

**Table 7.10** Setup Alarms and Messages, with Probable Cause and Corrective Action

<b>Display Message</b>	<b>Alarm Condition/Cause</b>	<b>Corrective Action</b>
Missing Part Conflict	The missing part maximum distance is equal to or greater than the plus reject absolute limit.	Change the missing part maximum distance limit or +reject absolute limit through the Alarm Information screen or Setup menu.
Missing Part Conflict	The missing part minimum distance is equal to or greater than the plus reject absolute limit.	Change the missing part minimum distance limit or +reject absolute distance limit through the Alarm Information screen or Setup menu.
Missing Part Conflict	The missing part minimum distance is equal to or less than the plus reject trigger limit.	Change the missing part minimum distance limit or +reject trigger distance limit through the Alarm Information screen or Setup menu.
Missing Part Conflict	The missing part maximum distance is equal to or less than the plus suspect absolute limit.	Change the missing part maximum distance limit or +suspect absolute distance limit through the Alarm Information screen or Setup menu.
Missing Part Conflict	The missing part minimum distance is equal to or greater than the plus suspect absolute limit.	Change the missing part minimum distance limit or +suspect absolute distance limit through the Alarm Information screen or Setup menu.
Missing Part Conflict	The missing part maximum distance is equal to or less than the plus suspect trigger limit.	Change the missing part maximum distance limit or +suspect trigger distance limit through the Alarm Information screen or Setup menu.
Missing Part Conflict	The missing part minimum distance is equal to or greater than the plus suspect trigger limit.	Change the missing part minimum distance limit or +suspect trigger distance limit through the Alarm Information screen or Setup menu.
Missing Part Conflict	The missing part minimum distance is equal to or greater than the absolute distance cutoff	Change the missing part minimum distance limit or absolute cutoff through the Alarm Information screen or Setup menu.

**Table 7.10** Setup Alarms and Messages, with Probable Cause and Corrective Action

<b>Display Message</b>	<b>Alarm Condition/Cause</b>	<b>Corrective Action</b>
Missing Part Conflict	The missing part maximum distance is equal to or greater than the absolute distance cutoff.	Change the missing part maximum distance limit or absolute cutoff through the Alarm Information screen or Setup menu.
Missing Part Conflict	The missing part minimum distance is equal to or greater than the absolute distance setting. This alarm occurs in absolute mode only.	Change the missing part minimum distance limit or absolute distance through the Alarm Information screen or Setup menu.
Missing Part Conflict	The missing part maximum distance is equal to or greater than the absolute distance setting. This alarm occurs in absolute mode only.	Change the missing part maximum distance limit or absolute distance through the Alarm Information screen or Setup menu
Preset Conflict	Both the external selection of presets and sequencing are turned on.	Turn off one of these.
Pretrigger Conflict	The pretrigger distance is equal to or greater than the minus reject absolute limit.	Change the pretrigger distance or - reject absolute limit through the Alarm Information screen or Setup menu.
Pretrigger Conflict	The pretrigger distance is equal to or greater than the minus suspect absolute limit.	Change the pretrigger distance or - suspect absolute limit through the Alarm Information screen or Setup menu.
Pretrigger Conflict	The pretrigger distance is equal to or greater than the plus reject absolute limit.	Change the pretrigger distance or +reject absolute limit through the Alarm Information screen or Setup menu.
Pretrigger Conflict	The pretrigger distance is equal to or greater than the plus suspect absolute limit	Change the pretrigger distance or +suspect trigger limit through the Alarm Information screen or Setup menu.
Pretrigger Conflict	The pretrigger distance is equal to or greater than the plus reject trigger limit.	Change the pretrigger distance or +reject trigger limit through the Alarm Information screen or Setup menu.

**Table 7.10** Setup Alarms and Messages, with Probable Cause and Corrective Action

<b>Display Message</b>	<b>Alarm Condition/Cause</b>	<b>Corrective Action</b>
Pretrigger Conflict	The pretrigger distance is equal to or greater than the plus suspect trigger limit.	Change the pretrigger distance or +suspect trigger limit through the Alarm Information screen or Setup menu.
Pretrigger Conflict	The pretrigger distance is equal to or greater than the minus reject trigger limit.	Change the pretrigger distance or - reject trigger limit through the Alarm Information screen or Setup menu.
Pretrigger Conflict	The pretrigger distance is equal to or greater than the minus suspect trigger limit.	Change the pretrigger distance or - suspect trigger limit through the Alarm Information screen or Setup menu.
Pretrigger Conflict	The pretrigger distance is equal to or greater than the absolute cutoff distance	Change the pretrigger distance or absolute cutoff through the Alarm Information screen or Setup menu.
Pretrigger Conflict	The pretrigger distance is equal to or greater than the absolute distance.	Change the pretrigger distance or absolute distance through the Alarm Information screen or Setup menu.
- R Trg > - R Abs	The minus reject trigger limit is equal to or greater than the minus reject absolute limit.	Change the - reject trigger limit and/or the - reject absolute limit through the Alarm Information screen or Setup menu.
+R Trg > +R Abs	The plus reject trigger limit is equal to or greater than the plus reject absolute distance limit.	Change the +reject trigger limit and/or the +reject absolute distance limit through the Alarm Information screen or Setup menu.
Trg > Weld Force	The requested trigger force is equal to or greater than the requested weld force.	Either increase the weld force setting or decrease the trigger force setting.
- R Trg > Abs	The minus reject trigger limit is greater than or equal to the absolute distance.	Change the - reject trigger limit and/or the absolute distance through the Alarm Information screen or Setup menu.
- R Trg > +S Abs	The minus reject trigger limit is greater than or equal to the plus suspect absolute distance limit.	Change the - reject trigger limit and/or the +suspect absolute distance limit through the Alarm Information screen or Setup menu.

**Table 7.10** Setup Alarms and Messages, with Probable Cause and Corrective Action

Display Message	Alarm Condition/Cause	Corrective Action
- R Trg > +R Abs	The minus reject trigger limit is greater than or equal to the plus reject absolute distance limit.	Change the - reject trigger limit and/or the +reject absolute distance limit through the Alarm Information screen or Setup menu.
Sequence Empty	Preset sequencing is enabled and a start signal has been received, but there is no sequence defined.	Define sequence.
- S Trg > Abs	The minus suspect trigger limit is greater than or equal to the absolute distance.	Change the - suspect trigger limit and/or the absolute distance through the Alarm Information screen or Setup menu.
- S Trg > - S Abs	The minus suspect trigger limit value is equal to or greater than the minus suspect absolute distance limit.	Change the - suspect trigger limit and/or the - suspect absolute distance limit through the Alarm Information screen or Setup menu.
+S Trg > +S Abs	The plus suspect trigger limit is equal to or greater than the plus suspect absolute limit.	Change the +suspect trigger limit and/or the +suspect absolute limit through the Alarm Information screen or Setup menu.
Trg S/R Limit Cross	The plus reject trigger distance limit is equal to or less than the minus suspect trigger distance limit.	Change the +reject trigger limit or - suspect trigger limit through the Alarm Information screen or Setup menu.
Trg S/R Limit Cross	The plus suspect trigger distance limit is equal or less than the minus reject trigger distance limit.	Change the +suspect trigger limit or - reject trigger limit through the Alarm Information screen or Setup menu.
Trg S/R Limit Cross	The plus reject trigger distance limit is equal to or less than the plus suspect trigger distance limit.	Change the +reject trigger limit or +suspect trigger limit through the Alarm Information screen or Setup menu.
Trg S/R Limit Cross	The minus reject trigger distance limit is equal to or greater than the minus suspect trigger distance limit.	Change the - reject trigger limit or - suspect trigger limit through the Alarm Information screen or Setup menu.
+ - Trg Limit Crossed	The reject limits for trigger distance that you have entered are reversed.	Change the reject trigger distance limits through the Alarm Information screen or Setup menu.

**Table 7.10** Setup Alarms and Messages, with Probable Cause and Corrective Action

<b>Display Message</b>	<b>Alarm Condition/Cause</b>	<b>Corrective Action</b>
+ - Trg Limit Crossed	The suspect limits for trigger distance that you have entered are reversed.	Change the suspect trigger distance limits through the Alarm Information screen or Setup menu.
Trg Force Conflict	The trigger force is equal to or greater than the plus suspect weld force limit.	Change the trigger force and/or the +suspect weld force limit through the Alarm Information screen or Setup menu.
Trg Force Conflict	The trigger force is equal to or greater than the plus reject weld force limit.	Change the trigger force and/or the +reject weld force limit through the Alarm Information screen or Setup menu.
- R Trg > - R Abs	The reject lower limit you have set for trigger is less than the lower limit you have set for absolute distance.	Change the reject limits for trigger distance and/or the limits for the absolute distance.
+R Trg > +R Abs	The reject upper limit you have set for trigger is greater than the upper limit you have set for absolute distance.	Change the reject limits for trigger distance and/or the limits you have set for absolute distance.
- S Trg > - S Abs	The suspect lower limit you have set for trigger is less than the lower limit you have set for absolute distance.	Change the suspect limits for trigger distance and/or the limits you have set for absolute distance.
+S Trg > +S Abs	The suspect upper limit you have set for trigger is greater than the upper limit you have set for absolute distance.	Change the suspect limits for trigger distance and/or the limits you have set for absolute distance.
- S Trg > +S Abs	The minus suspect trigger limit is equal to or greater than the plus suspect absolute limit.	Change the - suspect trigger limit and/or the +suspect absolute limit through the Alarm Information screen or Setup menu.
+S Trg > - S Abs	The plus suspect trigger limit is equal to or greater than the plus suspect absolute limit.	Change the +suspect trigger limit and/or the - suspect absolute limit through the Alarm Information screen or Setup menu.
- S Trg > Abs	The minus suspect trigger limit is greater than or equal to the absolute distance.	Change the - suspect trigger limit and/or the absolute distance through the Alarm Information screen or Setup menu.

**Table 7.10** Setup Alarms and Messages, with Probable Cause and Corrective Action

Display Message	Alarm Condition/Cause	Corrective Action
- S Trg > - S Abs	The minus suspect trigger limit value is equal to or greater than the minus suspect absolute distance limit.	Change the - suspect trigger limit and/or the - suspect absolute distance limit through the Alarm Information screen or Setup menu.
+S Trg > +S Abs	The plus suspect trigger limit is equal to or greater than the plus suspect absolute limit.	Change the +suspect trigger limit and/or the +suspect absolute limit through the Alarm Information screen or Setup menu.
Trg S/R Limit Cross	The plus reject trigger distance limit is equal to or less than the minus suspect trigger distance limit.	Change the +reject trigger limit or - suspect trigger limit through the Alarm Information screen or Setup menu.
Trg S/R Limit Cross	The plus suspect trigger distance limit is equal or less than the minus reject trigger distance limit.	Change the +suspect trigger limit or - reject trigger limit through the Alarm Information screen or Setup menu.
Trg S/R Limit Cross	The plus reject trigger distance limit is equal to or less than the plus suspect trigger distance limit.	Change the +reject trigger limit or +suspect trigger limit through the Alarm Information screen or Setup menu.
Trg S/R Limit Cross	The minus reject trigger distance limit is equal to or greater than the minus suspect trigger distance limit.	Change the - reject trigger limit or - suspect trigger limit through the Alarm Information screen or Setup menu.
+ - Trg Limit Crossed	The reject limits for trigger distance that you have entered are reversed.	Change the reject trigger distance limits through the Alarm Information screen or Setup menu.
+ - Trg Limit Crossed	The suspect limits for trigger distance that you have entered are reversed.	Change the suspect trigger distance limits through the Alarm Information screen or Setup menu.
Trg Force Conflict	The trigger force is equal to or greater than the plus suspect weld force limit.	Change the trigger force and/or the +suspect weld force limit through the Alarm Information screen or Setup menu.
Trg Force Conflict	The trigger force is equal to or greater than the plus reject weld force limit.	Change the trigger force and/or the +reject weld force limit through the Alarm Information screen or Setup menu.

**Table 7.10** Setup Alarms and Messages, with Probable Cause and Corrective Action

Display Message	Alarm Condition/Cause	Corrective Action
- R Trg > - R Abs	The reject lower limit you have set for trigger is less than the lower limit you have set for absolute distance.	Change the reject limits for trigger distance and/or the limits for the absolute distance.
+R Trg > +R Abs	The reject upper limit you have set for trigger is greater than the upper limit you have set for absolute distance.	Change the reject limits for trigger distance and/or the limits you have set for absolute distance.
- S Trg > - S Abs	The suspect lower limit you have set for trigger is less than the lower limit you have set for absolute distance.	Change the suspect limits for trigger distance and/or the limits you have set for absolute distance.
+S Trg > +S Abs	The suspect upper limit you have set for trigger is greater than the upper limit you have set for absolute distance.	Change the suspect limits for trigger distance and/or the limits you have set for absolute distance.
- S Trg > +S Abs	The minus suspect trigger limit is equal to or greater than the plus suspect absolute limit.	Change the - suspect trigger limit and/or the +suspect absolute limit through the Alarm Information screen or Setup menu.
+S Trg > - S Abs	The plus suspect trigger limit is equal to or greater than the plus suspect absolute limit.	Change the +suspect trigger limit and/or the - suspect absolute limit through the Alarm Information screen or Setup menu.

### 7.5.7 Overload Alarms

You encounter an overload alarm when your ultrasonic power supply has overloaded. The specific overload that has occurred is indicated by the message on your display.

The following table details the overload alarms that you can encounter on the 2000X Power Supply. The message on the display panel of the Power Supply is shown in the first column. The second and third columns indicate what condition led to the alarm and the corrective action you should take.

If you are using a Digital Power Supply, frequency, phase, current and voltage information is also available for each of the overload alarms listed in [Table 7.11 Overload Alarms](#).

**Table 7.11** Overload Alarms

Display Message	Alarm Condition/Cause	Corrective Action
Afterburst Overload	<p>An overload occurred during afterburst.</p> <p>An overload occurred during afterburst. The @ Time and frequency (Freq Chg) is from the start of afterburst. Peak power is at the time of the overload.</p>	Check the stack. Repair/ Replace the Power Supply Module.
Energy Braking Overload	UPS overload was detected in hold state. Alarm is called 'Energy Braking' because it could be caused by power supply overload during Energy Braking state, but the state is designed to ignore overloads.	Turn off Energy Braking, and call for application assistance.
Pretrigger Overload	The @Time is from start of pretrigger, the frequency and peak power is at the time of the overload.	Check the stack. Repair/ Replace the Power Supply Module.
Post Weld Seek O/L	An overload occurred during post weld seek. The @ Time and frequency change (Freq chg) are from the start of seek. The peak power is at the time of the overload.	Check the stack. Repair/ Replace the Power Supply Module.
Weld O/L	The ultrasonic power supply was overloaded during the weld cycle. The @ Time and frequency change (Freq Chg) are from trigger. Peak power is at the time of the overload.	Check the Peak Power reading in Weld Results. If Peak Power is above 100%, reduce your amplitude and/or force settings.
Seek Overload	The ultrasonic power supply was overloaded during the seek cycle at power up.	<p>Check the stack. Repair/ Replace the Power Supply Module.</p> <p>For digital UPS only, check that the stack is properly attached and the RF cable is hooked up.</p>

**Table 7.11** Overload Alarms

Display Message	Alarm Condition/Cause	Corrective Action
Test Overload	The ultrasonic power supply was overloaded during the test cycle. Pressing Test will clear the overload before the power supply goes into test mode. A new cycle can't be run until reset is pressed, even though test can be pressed again.	Check the stack. Repair/ Replace the Power Supply Module.  For digital UPS only, check that the stack is properly attached and the RF cable is hooked up.

### 7.5.8 Note Alarms

In addition to the previously described alarms there are several Note alarms that the Controls can issue to alert you that an alarm is imminent, or that the cycle ran with authorized modifications.

The following table details the Note alarms you can encounter on the 2000X Power Supply. The message on the display panel of the Power Supply is shown in the first column. The second and third columns indicate the condition that led to the alarm and the corrective action you should take.


**Table 7.12** Note Alarms

Display Message	Alarm Condition/Cause	Corrective Action
Absolute Cutoff	The absolute cutoff distance that you requested has been reached.	Manually inspect the part. If, with acceptable parts, you repeatedly get this alarm, reset your Absolute cutoff.
Act Clr Not Reached	The actual absolute distance reached during the weld cycle did not reach the Actuator clear distance that you set.	Using Horn Down to obtain size and distance readings, reset your Actuator Clear Distance to an obtainable value.
Act Recal Suggested	A preset has been loaded and calibration should be run.	Calibrate Actuator through Note menu, or calibrate from the Main Menu.
Absolute Cutoff	The absolute cutoff distance that you requested has been reached.	Manually inspect the part. If, with acceptable parts, you repeatedly get this alarm, reset your Absolute cutoff.
Act Clr Not Reached	The actual absolute distance reached during the weld cycle did not reach the Actuator clear distance that you set.	Using Horn Down to obtain size and distance readings, reset your Actuator Clear Distance to an obtainable value.

**Table 7.12** Note Alarms

Display Message	Alarm Condition/Cause	Corrective Action
Act Recal Suggested	A preset has been loaded and calibration should be run.	Calibrate Actuator through Note menu, or calibrate from the Main Menu.
Act Recal Suggested	A preset has been loaded and calibration should be run.	Additional information will not be available if the carriage is not at upper limit, the actuator Novram has failed or the palm buttons are still pressed. This note will be disabled when the preset has been recalled via external preset selection, through the host or sequencing.
Collapse Cutoff	The collapse cutoff distance you requested has been reached.	Manually inspect the part. If you repeatedly get this alarm with acceptable parts, reset your collapse cutoff.
Max Energy Reached	The maximum energy compensation value has been reached.	None. This is only a notice that an adaptive control feature that you programmed is in use.
Sonics Disabled	A complete weld cycle has been run but the ultrasonics were disabled by a user defined input.	Remove 24V from Sonics Disable input; undefine Sonics Disable input pin.
Time Extended	Weld time has been extended up to 50% for energy compensation. This alarm occurs in Time Mode only.	None. This is only a notice that an adaptive control feature that you programmed is in use.
USB Memory Nearly Full	The USB memory stick is over 98% full. At the current rate of storing, this is enough room for less than 100 welds. When full the welder will stop cycling.	Replace USB memory stick.

## 7.6 Service Events

WARNING	
	<p>Service events should be performed only by qualified individuals. The potential for injury or death exists, as well as that for damage to the equipment (which can include loss of product warranty) or loss of valuable setup information for your application.</p> <p>When servicing the system, the service person(s) can have a need for certain conventional hand tools, and you might need to have the following information for testing or returning the system to service.</p>

### 7.6.1 Required Tools

Special tools for the ultrasonic Converter, such as spanner wrenches, are provided with your system. You might also need the following hand tools or service tools:

- Six-inch or longer Phillips-head screwdriver with a magnetic tip or screw starter
- Good-quality multi-meter for continuity, AC and DC voltages, and resistance, with insulated test probes

### 7.6.2 Voltage Test Points

Remove the cover and pivot the DC Power Supply. See [7.7.6 DC Power Supply](#).

**Table 7.13** Voltage Test Points


DC Power Supply
TB2-1 to TB2-4 = +12vdc
TB2-2 to TB2-4 = - 12vdc
TB2-3 to TB2-4 = +24vdc
TB2-7 to TB2-6 = +5vdc

### 7.6.3 Cold Start Procedures

The Power Supply internal memory stores the system default settings and the parameters that you set. It also provides temporary storage to support the Power Supply internal functions. A cold start clears the Weld Setup Menu values and restores them to original factory defaults. It is not necessary to perform a cold start during normal operation and servicing, but you might find a cold start helpful when:

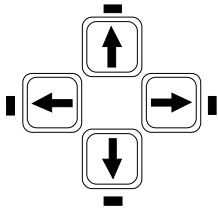
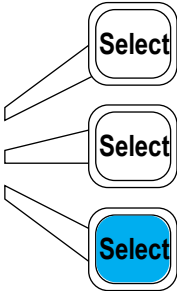
- You suspect the system is not operating properly
- You want to make a new setup

Some system memory locations and parameters, such as internal power supply history and serial number information, will not be cleared by these Cold Start procedures.

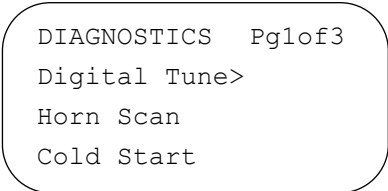
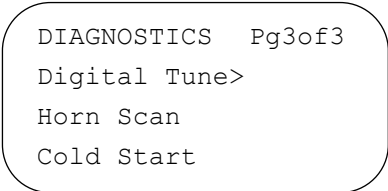
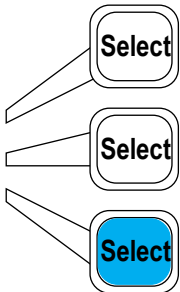
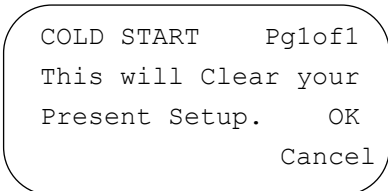
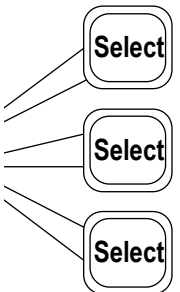
NOTICE	
	<p>Using the Cold Start procedures will erase your Setup parameters. Be sure you have a record of your setup if you want to retain it.</p>

## Performing a Cold Start


**Table 7.14** Performing a Cold Start

Take this action	To get this result	Key
<p>From the <b>Main Menu</b>, scroll down until you see <b>Diagnostics</b>.</p> <p>Press the <b>Select</b> key that corresponds to <b>Diagnostics</b>.</p>	<pre> MAIN MENU    Pg3of6 Save/Recall Presets Print Menu Diagnostics           </pre>	
<p>You will see the <b>DIAGNOSTICS</b> submenu.</p>	<pre> DIAGNOSTICS  Pg1of3 F Memory  [ ] [ ] [ ] F Actual  [ ] [ ] [ ] R=[ ] Sk=[ ] C=[ ] ST=[ ]           </pre>	

**Table 7.14** Performing a Cold Start

Take this action	To get this result	Key
<p>Use the down arrow key to scroll downward through the Diagnostics menu until you see <b>Cold Start</b>.</p>	 <pre> DIAGNOSTICS Pg1of3 Digital Tune&gt; Horn Scan Cold Start                     </pre>	
<p>Press the <b>Select</b> key that corresponds to <b>Cold Start</b>.</p>	 <pre> DIAGNOSTICS Pg3of3 Digital Tune&gt; Horn Scan Cold Start                     </pre>	
<p>You will see the <b>COLD START</b> submenu. Press the <b>Select</b> key that corresponds to <b>OK</b>.</p> <p>The display returns to the <b>Weld Setup menu</b> when the Cold Start is complete.</p>	 <pre> COLD START Pg1of1 This will Clear your Present Setup. OK Cancel                     </pre>	

## 7.7 Parts Replacement

CAUTION	
	<p>The 2000X Power Supply contains components that can be degraded or damaged by electrostatic discharge. Always use a Grounded Wriststrap and use a grounded work area when handling or servicing the 2000X Power Supply.</p> <p>In the following paragraphs, you are provided instructions on removing and replacing components. Before you begin to disassemble any parts of the Power Supply, ensure that the Power Supply is turned off, and the main power is disconnected. After the Power Supply cover is removed, wait at least two minutes to allow capacitors to discharge. When necessary, refer to <a href="#">Figure 7.3 Exploded View of all 2000 Modules</a> and <a href="#">Figure 7.4 Front Panel, Exploded Parts View</a> to help you with these procedures.</p>

The 2000X Power Supply is designed for a long service life. In the event the system malfunctions, many of the internal components (Modules) are replaceable as a unit. If a particular module has failed, it should be replaced or repaired at a Branson Depot Facility.

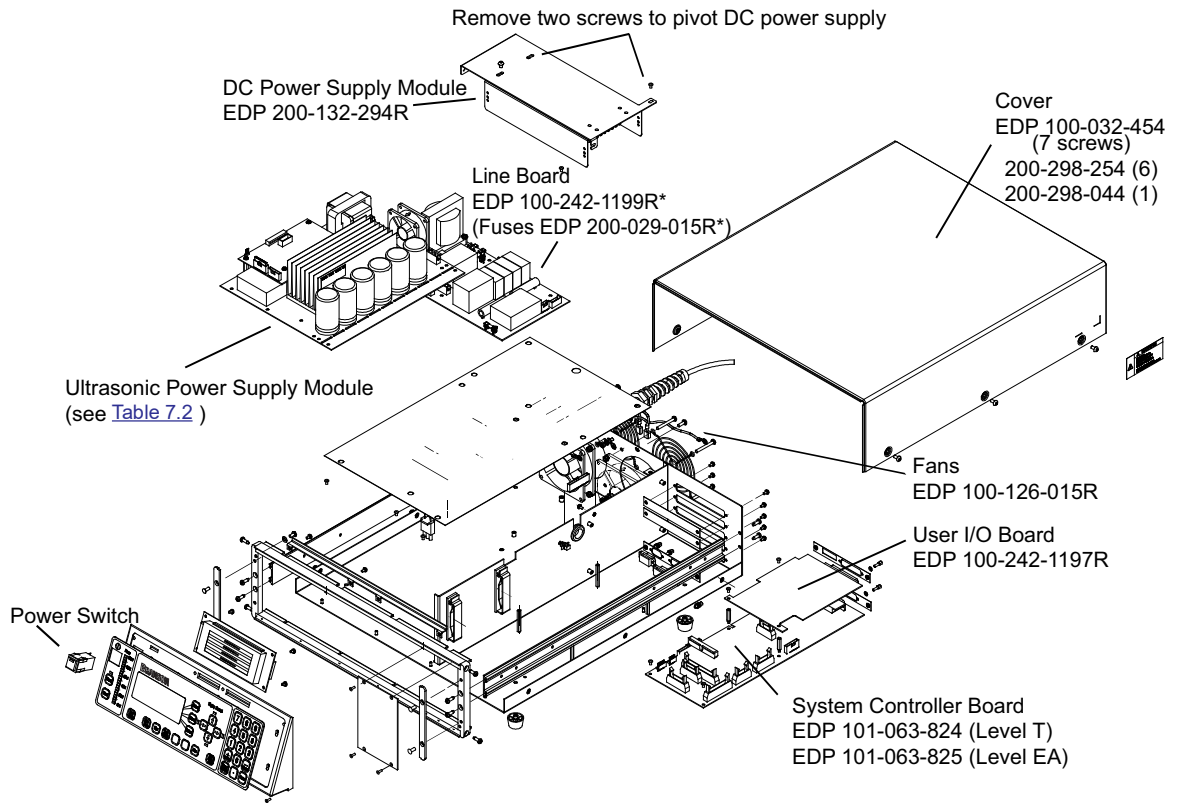
The 2000 system is designed with an extensive Alarms Message system. Refer to the list of error messages to assist your troubleshooting. These error codes are described in [7.4 Troubleshooting](#).

The following parts are replaceable. Refer to the following exploded view of the Power Supply to see the location of each of these components or modules.

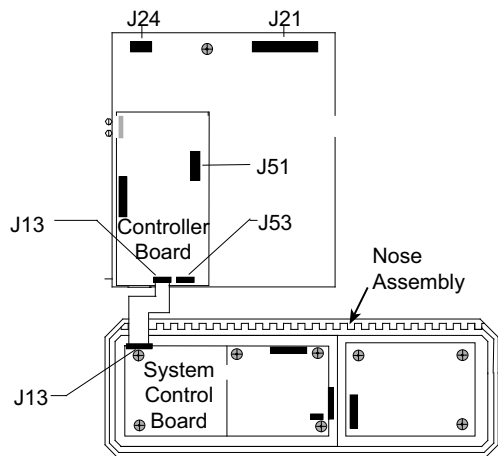
### 7.7.1 Power Supply Cover

The Cover is held in place with seven screws, three on each side of the case and one on the rear. Lift the rear of the cover up to remove it. The Cover must be in place when the system is operating due to fan-forced ventilation design. See [Figure 7.3 Exploded View of all 2000 Modules](#) for a view of the Cover.

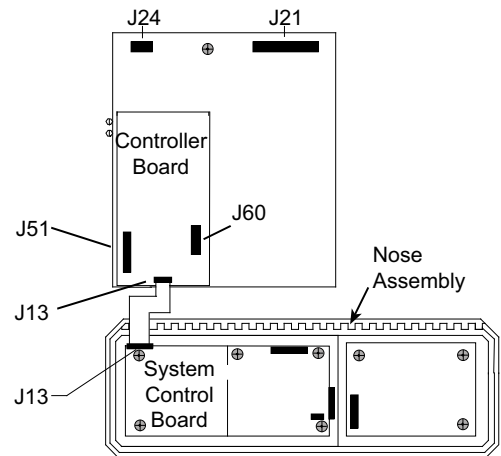
**Figure 7.3** Exploded View of all 2000 Modules



Analog  
Ultrasonic Power Supply Module  
Top View

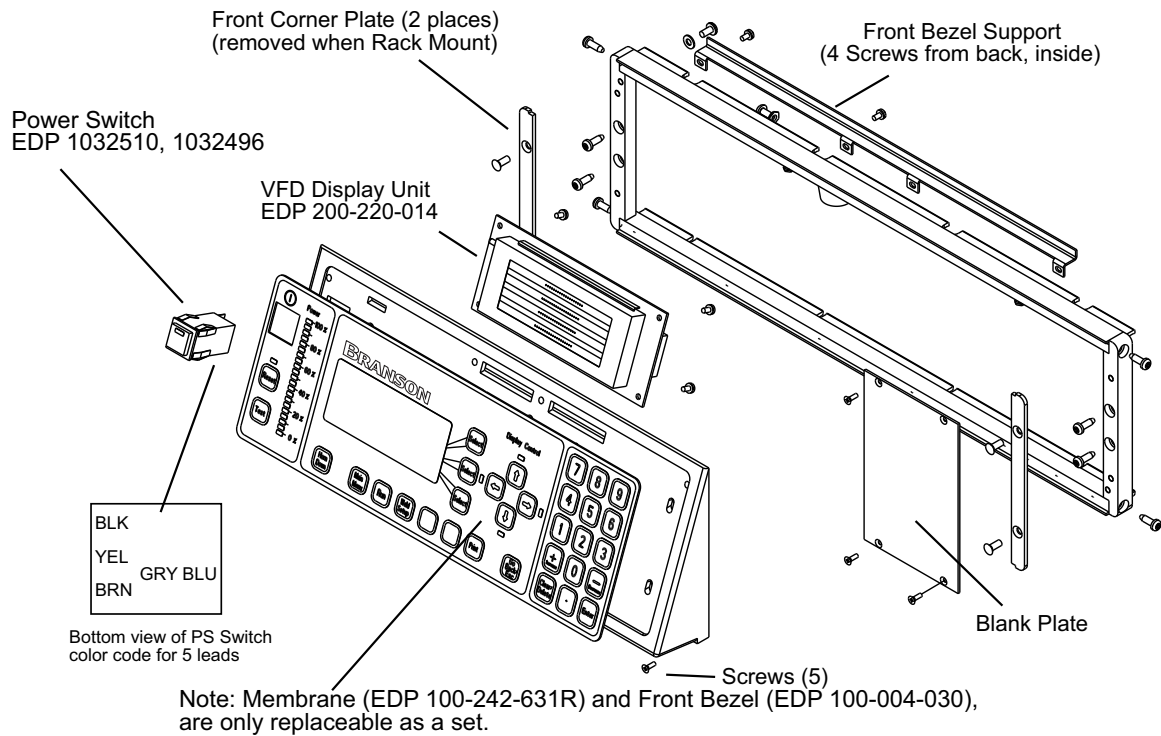


Digital  
Ultrasonic Power Supply Module  
Top View



\*4KW units use line board 100-242-1230R with Fuses 200-049-146R

**Figure 7.4** Front Panel, Exploded Parts View



## 7.7.2 Circuit Boards and Modules

Replaceable Modules are shown in [Figure 7.3 Exploded View of all 2000 Modules](#). Ribbon cables and connectors are unique and keyed to prevent the misconnection of an appropriate connector in a location within the Power Supply case. Fans use identical wiring harnesses, with one tying back the 'extra' lead length.

Make note of any wiring paths if you are removing a module, before you disassemble. In some cases, there are several possible paths, but one preferred location. Be especially careful with harnesses and wires that go between the two portions of the case, as they can be pinched by the metal case if mis-routed.

## 7.7.3 Power Switch and Lamp

The Power Switch with its integral lamp is a field-replaceable component. It uses a 5-conductor wiring harness. The switch leads are depicted, by color code, in [Figure 7.4 Front Panel, Exploded Parts View](#), looking at the bottom of the switch. To replace the switch, disconnect power and push the switch out from the rear of the front bezel assembly. Disconnect the wires and, in reverse order, reinstall the new switch with the integral lamp toward the top side.

### 7.7.4 Front Panel Membrane and VFD Display

The Front Panel Membrane and Bezel are supplied as a single assembly.


The VFD Display is removable from the back of the Bezel/Membrane unit and can be replaced separately. You remove the Front Bezel by removing the four screws from the Bezel Support, and then lifting the Bezel up and out.

#### To remove the VFD Display, take the following steps

**Table 7.15** Removing the VDF Display


Step	Action
1	Turn off the Power Supply. Unplug the main power.
2	Allow at least 5 minutes for capacitor discharge.
3	Using a #2 Philips screwdriver, remove 7 screws from the 2000X cover (3 on each side, 1 on the rear). Remove the cover.
4	Using a #1 Philips screwdriver, loosen, from inside the unit, the 4 screws on the Front Bezel Support.
5	Using a #1 Philips screwdriver, remove 5 screws from the Front Bezel (bottom front).
6	Disconnect the membrane connectors from the System Controller Board.
7	Disconnect the cable clamps.
8	Disconnect the leads from the Power Switch Assembly.
9	Disconnect J36 on the System Controller Board.
10	Disconnect the VFD ground strap.
11	Lift the front panel up and out.
12	Tip the Front Bezel forward.
13	Disconnect the cable from the VFD board.
14	Remove 4 screws from the VFD board.
15	Remove the VFD board.

**To reinstall the VFD Board, reverse the removal procedures.**

NOTICE	
	<p>Be sure the VFD is installed in its original orientation. When reinstalling and dressing the membrane connectors, do the longest one first.</p>

## 7.7.5 Power Supply Module

The ultrasonic Power Supply Module is affixed to the bottom of the power supply box with four screws through the bottom board. To remove the Power Supply Module, perform the following steps listed in [Table 7.16 Removing the Power Supply Module](#).

CAUTION	
	<p>Transfer the DIP switch settings from the original module to the new module.</p> <p>If installing a 1.1kw or 800w Power Supply Module into a 117 vac Power Supply, move the 115/230 jumper to the 115 position.</p>

### To remove the Power Supply Module, take the following steps

**Table 7.16** Removing the Power Supply Module

Step	Action
1	Turn off the Power Supply.
2	Unplug the main power.
3	Allow at least 5 minutes for capacitor discharge.
4	Using a #2 Philips screwdriver, remove 7 screws from the 2000X cover (3 on each side, 1 on the rear). Remove the cover.
5	Remove the nose assembly as shown in <a href="#">Figure 7.4 Front Panel, Exploded Parts View</a> .
6	Disconnect P13, P51, and P53 (analog module), or P60 (digital module) from controller board as shown in <a href="#">Figure 7.3 Exploded View of all 2000 Modules</a> .
7	Disconnect P21 and P24 from the lower board as shown in <a href="#">Figure 7.3 Exploded View of all 2000 Modules</a> .
8	Use a Phillips screwdriver to remove retaining screws.
9	Slide the module out of the Power Supply.

**To reinstall the DC Power Supply, reverse the removal procedure.**

## 7.7.6 DC Power Supply


The DC Power Supply is mounted to the rear of the Power Supply case. It is mounted so it will swivel up to service the DC Power Supply, Line Board, and fuses. See [Figure 7.3 Exploded View of all 2000 Modules](#).

### To remove the DC Power Supply, take the following steps

**Table 7.17** Removing the DC Power Supply

Step	Action
1	Turn off the Power Supply.
2	Unplug the main power.
3	Allow at least 5 minutes for capacitor discharge.
4	Using a #2 Philips screwdriver, remove 7 screws from the 2000X cover (3 on each side, 1 on the rear). Remove the cover.
5	Using a #1 Philips screwdriver, on the top of the DC Power Supply, remove 1 rear screw.
6	Using a #1 Philips screwdriver, on the left side of the DC Power Supply, remove the rear screw.
7	Rotate the DC Power Supply up to allow you access to connectors.
8	Disconnect the 5-pin connector (TB1).
9	Disconnect the 16-pin connector (TB2).
10	Disconnect pin 5 (red) and pin 6 (black) noting the wire colors.
11	On the top of the DC Power Supply, remove 4 screws.
12	Remove the DC Power Supply.

**To reinstall the DC Power Supply, reverse the removal procedure.**

NOTICE	
	<p>When reconnecting wires, observe the color coding that you previously noted. When installing the connectors, to TB1 and TB2, ensure the wires from the connectors are turned toward the outside of the unit.</p>

## 7.7.7 User I/O Board

The User I/O Board is the short interface board. It is mounted to the System Controller Board on standoffs, and is connected to the rear of the Power Supply case by its end panel.


### To remove the User I/O Board, take the following steps

**Table 7.18** Removing the User I/O Board

Step	Action
1	Turn off the Power Supply.
2	Unplug the main power.
3	Allow at least 5 minutes for capacitor discharge.
4	Using a #2 Philips screwdriver, remove 7 screws from the 2000X cover (3 on each side, 1 on the rear). Remove the cover.
5	Disconnect J41.
6	Using a #1 Philips screwdriver, remove the 2 end panel screws.
7	Using a #1 Philips screwdriver, remove the 2 internal (M3) mounting screws.
8	Remove the User I/O board.
9	If the new User I/O Board does not have rear mounting plate, transfer it from the old board.

**To reinstall the User I/O Board, reverse the removal procedures.**

## 7.7.8 Battery for Backup RAM (BBRAM)

NOTICE	
	<p>When the battery is worn out, dispose it under the ordinance of each local government.</p>

## To remove and replace the BBRAM battery, take the following steps

**Table 7.19** Removing and Replacing the BBRAM battery

Step	Action
1	Turn off the Power Supply. Unplug the main power.
2	Allow at least 5 minutes for capacitor discharge.
3	Using a #2 Philips screwdriver, remove 7 screws from the 2000X cover (3 on each side, 1 on the rear). Remove the cover.
4	Remove and replace the battery (CR2032), located on the controller board.
5	Replace cover and screws. Plug in main power and turn on the Power Supply.

### 7.7.9 System Controller Board

#### To remove the System Controller Board, take the following steps

**Table 7.20** Removing the System Controller Board


Step	Action
1	Record all parameters from your weld setup.
2	Turn the Power Supply off. Disconnect it from Main power. Wait at least 5 minutes.
3	Using a #2 Philips screwdriver, remove 7 screws from the 2000X cover (3 on each side, 1 on the rear).
4	Observe all ESD precautions (grounding strap).
5	Remove the User I/O board. See <a href="#">7.7.7 User I/O Board</a> .
6	Remove all cables connected to the system controller. Note the path of the cable routing, and be careful that you do not cross the flexible transparent cable.
7	Remove all screws and standoffs that hold the System Controller in the chassis, including the 2 (M3) screws in the back panel.


**CAUTION**


Do not remove the 2 screws that secure the back panel plate to the D shell connector. If this is a board upgrade, the new level designation is located on the replacement assembly. If there still exists a need to remove the connector, **do not apply a torque greater than 4 in/lbs to the screws when reassembling.**

8	Remove the System Controller Board.
---	-------------------------------------

**To reinstall the System Controller Board, reverse the removal procedures and perform a Cold Start.**

CAUTION	
	<p>If this is a board upgrade, make certain to use the appropriate longer length standoffs to preclude interference problems.</p>

NOTICE	
	<p>You can verify the software version of your power supply either viewing it in the System Information menu, or by removing the power supply cover and reading the version number on the flash (ICs U53, U54, U55 and U56) located on the Controller Board.</p>

CAUTION	
	<p>Do not rely on the paper label for IC orientation.</p>


The triangle on the IC socket should be directly under the raised dot on the IC. The socket and IC also have a truncated corner to aid in alignment. The raised dot may also be located on the beveled surface of the IC.

**Figure 7.5** Location and Orientation of U53, U54, U55, and U56

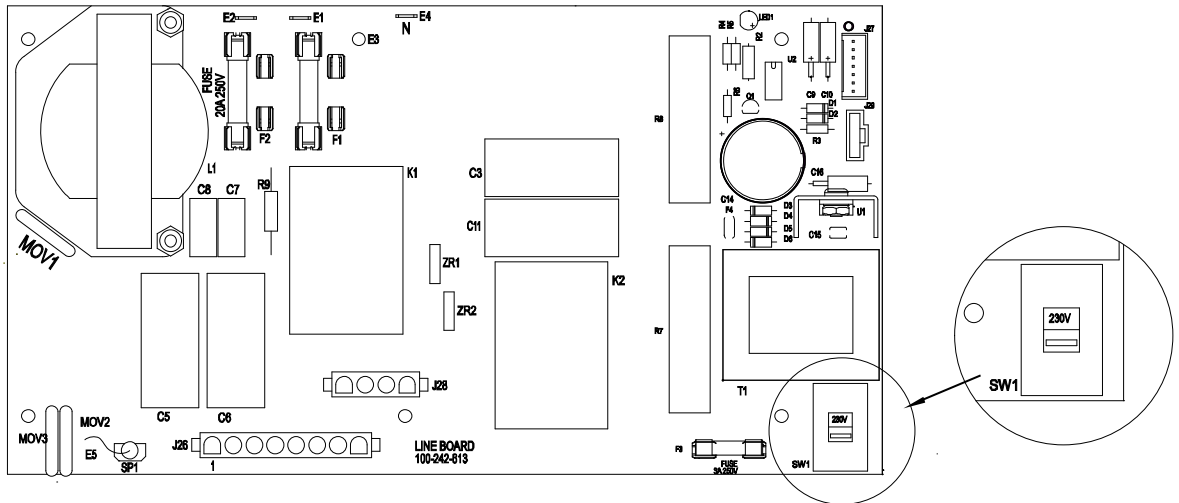


For installation information, please contact Branson Product Support (203.796.0400, extensions 373 or 355) or your local Branson Representative.

## 7.7.10 Line Board

CAUTION	
	<p>Refer to <a href="#">Figure 7.6</a> below to verify the voltage selector switch is configured properly for your intended operating voltage.</p>

**Figure 7.6** Lineboard EDP 100-242-1199R (100-242-1230R for 4kW Units)




## To remove the Line Board, take the following steps

**Table 7.21** Removing the Line Board

Step	Action
1	Turn off the Power Supply.
2	Unplug the main power.
3	Allow at least 5 minutes for capacitor discharge.
4	Using a #2 Philips screwdriver, remove 7 screws from the 2000X cover (3 on each side, 1 on the rear). Remove the cover.
5	Rotate the DC Power Supply up to allow you access to the Line Board. See <a href="#">7.7.6 DC Power Supply</a> .
6	Disconnect J26, J27, J28, and J29.
7	For 120 V systems, disconnect line labeled E1 and neutral labeled E4 or N. For 220 V systems, disconnect lines labeled E1 and E2. Note that the brown lead is the hot lead.
8	Remove 5 M3 screws (Philips) and 1 ground screw (common head).
9	Lift out the line board.

**To reinstall the Line Board, reverse the removal procedures.**

CAUTION	
	<p>When reconnecting wires, observe the color coding that you previously noted and the connections noted in step 5 above.</p>

### 7.7.11 Line Fuses

**To remove and replace the Line Fuses, take the following steps**

**Table 7.22** Removing and Replacing the Line Fuses

Step	Action
1	Turn off the Power Supply.
2	Unplug the main power.
3	Allow at least 5 minutes for capacitor discharge.
4	Using a #2 Philips screwdriver, remove 7 screws from the 2000X cover (3 on each side, 1 on the rear). Remove the cover.
5	Rotate the DC Power Supply up to allow you access to the Line Board. See <a href="#">7.7.6 DC Power Supply</a> .
6	Remove and replace the line fuse(s) located on the Line Board.

**Reassemble the Power Supply by reversing the above procedures.**


## 7.7.12 Cooling Fans

### To remove a Cooling Fan, take the following steps

**Table 7.23** Removing a Cooling Fan

Step	Action
1	Turn off the Power Supply.
2	Unplug the main power.
3	Allow at least 5 minutes for capacitor discharge.
4	Using a #2 Philips screwdriver, remove 7 screws from the 2000X cover (3 on each side, 1 on the rear). Remove the cover.
5	Rotate the DC Power Supply up to allow you access to the Fans. See <a href="#">7.7.6 DC Power Supply</a> .
6	Cut the tie-wraps from the fan wiring.
7	Disconnect the electrical connector(s).
8	Remove the 4 fan mounting screws and nuts.
9	Remove the fan and shield.

**To reinstall the a Cooling Fan, reverse the removal procedures while observing the direction of air flow.**

NOTICE	
	Be sure that you reinstall the fan shields on the back of the Power Supply.


---

## Appendix A: Automation

---

### A.1 FAQ: 2000 SERIES AUTOMATION ..... 266

This appendix supports automation Interface features on 2000 Series power supplies.

NOTICE	
	Refer to the Branson Automation Guide (EDP 100-214-273) for additional information about selection and use of features available to set up an automated ultrasonic welding process.

## A.1 FAQ: 2000 SERIES AUTOMATION

*Q. What is the best tip for automating a Branson welder?*

A. Perhaps the best advice is to provide a "manual jog" function where the welder can be cycled by the system control panel without indexing the whole machine. The time saved debugging, optimizing, calibrating and servicing the welder over it's lifetime will pay-back to the end-user and machine builder many times the cost of input hardware and code.

*Q. What are the electrical characteristics of the input/output lines in the START and USER I/O cables?*

A. They are rated at 10ma. 24Vdc. This is compatible with most PLCs available.

*Q. Can't I use 120 volt AC LOGIC?*

A. Not directly. Use relays to interface between the 2 logic levels. Note: use relays with low-power requirement coils, and use back biased diodes to suppress induced back EMF.

*Q. But you forgot about the RELAY outputs in your diagrams.*

A. They are SOLID STATE relays, and can safely withstand 40 V ac 250 ma, or 24 V dc, 250 ma. So they may be suited better to drive relays, if required to interface to relay coils.

*Q. Why do you have so many pins in the USER I/O cable?*

A. We combined the alarm and advanced feature connector outputs from the 900 Series with 2000 Series additions to provide maximum features and flexibility while retaining most feature backward compatibility.

*Q. What do I do with the UNUSED PINS?*

A. You should electrically isolate each unused pin so that shorts to ground and other outputs are avoided. This could possibly damage the USER I/O board and other system components.

*Q. Do I ground the shields on the START and USER I/O cables?*

A. No; leave the shields from the cables isolated and cut-back so they do *not* touch ground: this prevents ground loop interference from occurring.

*Q. Should I ground the RETURN lines in the START and USER I/O cables?*

A. If required: this generally is not a problem. If problems occur, see "OTHER THAN 24 VOLTS"

*Q. What are those SQUARE PLASTIC HOUSINGS on the cables?*

A. They are ferrites that are used to reduce crosstalk and interference from entering the system. DO NOT remove them.

*Q. How LONG can I run the CABLES?*

A. Cable sets are available in 8, 15, 25, and on special order 50-foot lengths. Contact Branson Product Support or Customer Service if you have special needs.

*Q. Can I run the Branson welder cables in a WIRING TROUGH with other system cables?*

A. Generally yes. But it would be best to avoid other noise trouble source cables or wiring.

*Q. What other system cables might cause a NOISE TROUBLE SOURCE?*

A. Avoid wiring of devices such as solenoids, large relays, motors, or anything that has the potential of large inductive currents. Digital devices may also create broad-spectrum noise. Generally, all automation controls can be noise generators.

*Q. Why do you require the READY signal to be monitored by the system PLC?*

A. The welder mandatory requirements dictate the unit be READY or else the unit will DISREGARD any start command.

*Q. Why can't I use a SINGLE START input to signal the welder?*

A. This is not preferable as you are running the signals in parallel, and cable capacitance can reduce the noise immunity designed into the controls. The dual inputs are required for the use of manual start switches, and the necessary circuit needs of an actuator welder utilizing solenoid valve control.

*Q. Why must I MAINTAIN THE START SIGNAL?*

A. This is the way the built-in safety circuits operate. Also, the vast library of error-detection firmware code is based on these same requirements: it will simplify automation system/PLC/welder debugging during system integration. Watch for the PB RELEASE signal, then you can release the START SIGNAL

*Q. My machine is CAM driven. Do I need to do anything special?*

A. For one thing, monitor the GENERAL ALARM output and send a RESET as soon as the alarm is received. This will allow the power supply to recover from a fault, and go to READY as soon as possible. Otherwise the next weld may be missed if the system is not reset. Also, see WITHOUT A BRANSON ACTUATOR below.

*Q. I'm going to use a welder station WITHOUT A BRANSON ACTUATOR. Do I need to use all those cables?*

A. If you only need a "stack" (converter/booster/horn) rather than a full featured actuator, you can use the USER I/O cable. This is a feature available in Version 8.05 operating system. An E-Stop jumper is required to connect Pin 32 (rtn) to pin 13 (source) at J7 on the actuator.

*Q. Does it wire up the same way?*

A. The USER I/O inputs wire the same way, and the start only needs a SINGLE START input from any available USER I/O input.

Q. *But you said you need DUAL START Inputs?*

A. Yes, when using a solenoid valve equipped actuator. But in this case we are only controlling ultrasonics. For this function a SINGLE START input works fine.

Q. *What can I do to make sure I run at MAXIMUM CYCLE RATE for my machine?*

A. You can:

RESET immediately after an GENERAL ALARM output

RELEASE the DUAL START inputs immediately after an GENERAL ALARM output

RELEASE the DUAL START inputs immediately after sensing PB RELEASE output

If you have a 2000d model: and if the stroke length is more than about 0.5 inches, turn on the ACTUATOR CLEAR function and set the distance value to whatever is required to clear the welded workpiece. Use the ACTUATOR CLEAR output to let your PLC index the material handling, rather than wait for the welder to become READY.

Never run in an open-loop mode, if possible. Fixed timing can be too short should a fault occur, or may be longer in time than is necessary.

Q. *Do all models run at the same CYCLE RATE?*

A. See above.

Q. *Are there any special requirements for operation with the ACTUATOR UP-SIDE DOWN?*

A. Always let Branson know when you plan to run in this manner. Model-specific advice will be provided.

Q. *Are there any special requirements for operation with the ACTUATOR HORIZONTAL?*

A. Always let Branson know when you plan to run in this manner. Model-specific advice will be provided.

Q. *How does EMERGENCY STOP work?*

A. Keep in mind that it is meant for EMERGENCY usage only, not for normal head retraction functions. Additional time is allotted for checking the welders' hardware and system status after an EMERGENCY STOP. Note: A front panel or external signal Reset is required after an Emergency Stop to reinitialize the welder. Also see CYCLE ABORT below.

Q. *So the CYCLE ABORT function is the preferred fast welder head retraction function?*

A. Yes. It does not require the additional time that is allotted for checking the welders' hardware and system status that is used for EMERGENCY STOP.

Q. *How does RESET work? Can I hold it on?*

A. RESET is only acted upon after a GENERAL ALARM. Do not hold it in the RESET state as it will be ignored.

Q. *My system logic uses some value OTHER THAN 24 VOLTS. What do I do?*

A. A set of dipswitches are provided on the rear panel slot that contains the USER I/O connector. Setting the switches to OFF (open) converts the 24volt USER I/O to OPEN COLLECTOR configuration. The same voltage/current spec.'s apply when in this mode. (24 volt dc, 25ma max.) Use them to control devices that have outputs compatible to your requirements.

Q. *Are there any environmental conditions to be concerned about?*

A. Any electrical/electronic equipment does not work well in: high humidity (condensing) conditions: also in dusty areas, in particular conductive dust (carbon granule or fiber, charcoal, metal particle, etc.)

A Fan Filter Kit with instructions can be factory or customer installed for just ordinary dusty areas.

Always contact your area representative, Branson Product Support or Customer Service should any like conditions or for inquires about explosion-proof requirements.

Q. *How much air consumption does the 2000 Series use?*

A. 2000 Series products use identical air cylinder sizes as prior models, therefore the air consumption tables from prior series documentation will still apply.

**Table A.1** Air Consumption

Air Pressure (PSI)	Cylinder Size			
	1.5	2	2.5	3
10	0.00174	0.00317	0.00490	0.00680
20	0.00243	0.00437	0.00680	0.00960
30	0.00312	0.00557	0.00870	0.01240
40	0.00381	0.00677	0.01060	0.01520
50	0.00450	0.00800	0.01250	0.01800
60	0.00513	0.00930	0.01440	0.02080
70	0.00590	0.01040	0.01630	0.02350
80	0.00660	0.01170	0.01830	0.02670
90	0.00730	0.01300	0.02040	0.02910
100	0.00800	0.01420	0.02230	0.03190

Cubic Feet of air per Minute per inch of stroke length (each direction)

Use the above table to calculate the air used by the air cylinder.

Add 0.034 Cubic foot per Second of actual weld time to account for converter cooling air per weld cycle. (2 CFM)

For example:

3.0 inch aed actuator running at full pressure (100psi) and stroke length (4 inches) at a cycle rate of 20 parts per minute = 0.0319 CFM per inch of stroke (from above table) X 8 inches (total stroke is 4 inches down and 4 inches back) equals 0.2552 CFM per stroke. Weld time is 1 second so: 0.034 X 1 equals 0.034 CFM for cooling.

Adding 0.2552 CFM for the cylinder and 0.034 CFM for cooling equals 0.2892 CFM per cycle. Multiply for parts per minute (20) and you get a total of 5.784 CFM.

This would very likely be a worst-case condition any welder could run at.

We would suggest to always use the 100 psi values from the above table to be on the conservative side for sizing airflow, rather than on the actual force values. Still add the same converter cooling values (0.034) as in the prior example.

---

## Appendix B: Alarm Index

---

This alarm index is an alphabetical list of the alarms that appear on the system display. All alarm page numbers are hyper-linked to the full description, which describes the cause of the alarm condition and the steps to resolve it.

### Symbols

- R Abs Dist Limit 229
- R Abs Dist Limit 228
- R Col Dist Limit 230
- R Energy Limit 228
- R Pk Power Limit 229
- R Time Limit 236
- R Trg >- R Abs 261
- R Weld Force Limit 236
- Reject Absolute Distance Limit 228, 229
- Reject Collapse Distance Limit 230
- Reject Energy Limit 228
- Reject Peak Power Limit 229
- Reject Time Limit 236
- Reject Weld Force Limit 236
- S Abs Dist Limit 228
- S Energy Limit 229
- S Pk Power Limit 229
- S Trg > - S Abs 260, 261
- S Trg > +S Abs 262
- S Trg > Abs 260
- Suspect Absolute Distance Limit 228
- Suspect Energy Limit 229
- Suspect Peak Power Limit 229
- + - Pwr Limit Crossed 246
- + - Time Limit Crossed 248
- + - Trg Limit Crossed 261
- + - Eng Limit Crossed 239
- + R Col Dist Limit 224
- + R Pk Power Limit 229
- + Reject Absolute Distance Limit 227
- + Reject Collapse Distance Limit 224
- + Reject Energy Limit 228
- + Reject Peak Power Limit 229
- + S Col Dist Limit 225
- + S Trg Dist Limit 225
- + Suspect Absolute Distance Limit 227
- + Suspect Collapse Distance Limit 225
- + Suspect Energy Limit 228

- + Suspect Peak Power Limit 229
- + Suspect Trigger Distance Limit 225
- +R Abs Dist Limit 225, 227
- +R Energy Limit 225, 228
- +R Pk Power Limit 225
- +R Time Limit 225
- +R Trg >+R Abs 261
- +R Trg Dist Limit 226
- +R Weld Force Limit 225, 226
- +Reject Absolute Distance Limit 225
- +Reject Energy Limit 225
- +Reject Peak Power Limit 225
- +Reject Time Limit 225
- +Reject Trigger Distance Limit 226
- +Reject Weld Force Limit 225, 226
- +S Abs Dist Limit 226, 227
- +S Col Dist Limit 226
- +S Energy Limit 226, 228
- +S Pk Power Limit 227, 229
- +S Time Limit 227
- +S Trg > - S Abs 262
- +S Trg > +S Abs 260, 262
- +S Trg Dist Limit 227
- +S Weld Force Limit 226
- +Suspect Absolute Distance Limit 226
- +Suspect Collapse Distance Limit 226
- +Suspect Energy Limit 226
- +Suspect Peak Power Limit 227
- +Suspect Time Limit 227
- +Suspect Trigger Distance Limit 227
- +Suspect Weld Force Limit 226
- A
- Abs Before Trg 222, 224
- ABS Cutoff 210
- Absolute Cutoff 264
- Absolute Distance Before Trigger 222, 224
- Absolute Distance Cutoff 210, 264
- Act Clr Not Reached 264
- Act Recal Suggested 264, 265
- Actuator Clear Distance Not Reached 264
- Actuator Clear Function (Failure) 214
- Actuator NovRam (failed)
  - Error Code = 10 214
  - Error Code = 20 215
  - Error Code = 30 215
  - Error Code = 40 215
  - Error Code = 50 215
  - Error Code = 60 215
- Actuator Type 214

Afterburst Overload 262  
Amp Step Before Trg (Trigger) 222, 224  
Amp Step Conflict 236, 237  
C  
Collapse Cutoff 265  
Collapse Distance for Amplitude Step not Reached 213  
Cutoff Conflict 237, 238  
D  
Door/Trigger Switch (failure) 215  
E  
Energy Comp Conflict 238  
Energy Comp Crossed 239  
Energy Compensation Maximum Energy Reached 265  
Energy Not Reached 228  
Energy Value for Amplitude Step not Reached 213  
Eng S/R Limit Cross 239  
External signal for Amplitude Step did not occur 211, 212  
F  
Failure of Preset Data or Battery Backed RAM 217  
For optimum performance recalibrate your Actuator 264  
Force A > Pressure 242  
Force B > Pressure 242  
Force Step Conflict 243, 244, 245  
Force/Lmt Conflict 242, 243  
G  
Ground Detect Abort 210, 222  
H  
Hold Force > Pressure 245  
Horn Return Timeout 216  
I  
Invalid Preset Error Code = 1 250  
Invalid Preset Error Code = 2 250  
Invalid Preset Error Code = 3 250  
Invalid Preset Error Code = 4 250  
Invalid Preset Error Code = 5 250  
Invalid Preset Error Code = 6 250  
Invalid Preset Error Code = 7 250  
Invalid Preset Error Code = 8 250  
M  
Max Energy Reached 265  
Max Timeout 210  
Missing Part Abort 223  
N  
No Amplitude Step 211  
    Collapse Distance for Amplitude Step not Reached 213  
    Energy Value for Amplitude Step not Reached 213  
    External signal for Amplitude Step did not occur 211, 212  
    Power level for Amplitude Step not Reached 212  
No Force Step 245

## P

P/S NovRam 216  
Peak Power Cutoff 213  
Post Weld Seek (O/L) Overload 263  
Power level for Amplitude Step not Reached 212  
Power Supply NovRam Failed 216  
Preset Data/BBR 217  
Pressure > Weld Force 245  
Pretrigger Overload 263  
Pretrigger Timeout 217  
Pwr S/R Limit Cross 246

## R

Rapid Trav. Conflict 247  
Recalibrate Actuator  
    Error Code = 100 217  
    Error Code = 1000 218, 219  
    Error Code = 200 217  
    Error Code = 300 217  
    Error Code = 400 218  
    Error Code = 600 218  
    Error Code = 700 218  
    Error Code = 800 218  
    Error Code = 900 218

## S

Seek Overload 263  
Start Sw Time 219  
Start Switch Closed (Failure) 219  
Start Switch Stagger Time Missed 219  
Start Switches Lost 219  
Sys. Pres. Incorrect 248

## T

Test Overload 264  
The Actuator Type was changed since the last weld cycle 214  
Thermal Overload 220  
Time Extended 266  
Time S/R Limit Cross 248  
Time Value for Amplitude Step not Reached 211  
Timeout Conflict 248, 249  
Trg Force Conflict 261  
Trg S/R Limit Cross 261  
Trig (Trigger) Before Pretrig 223  
Trigger > Weld Force 213  
Trigger is greater than the Weld Force 213  
Trigger Lost during Hold 213  
Trigger Lost during Weld 214  
Trigger Lost in Hold 213  
Trigger Lost in Weld 214  
Trigger Timeout 224

U

Ultrasonics P/S 220

Ultrasonics Power Supply Not Present or Failed 220

Upper Limit Switch 220

Upper Limit Switch Failed 220

W

Weld Force > pressure 250

Weld O/L 263

Weld Overload 263

Weld Time was Extended for Energy Compensation 266

Wrong Actuator 221

Wrong Actuator AEF/AOF cannot be used with this level control 221



---

## **Appendix C: Manual Revisions**

---

**C.1 Manual Revisions. . . . . 278**

## C.1 Manual Revisions

Refer to the following table to look for the appropriate manual revision for your Power Supply depending on the date of manufacture, which is found on a label on the back of the Power Supply.

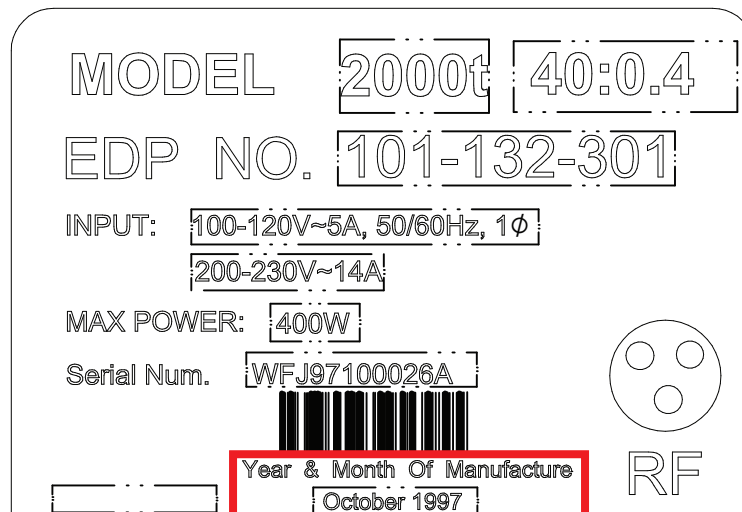
**Table C.1** Revisions of Manual

Revision number of Manual	Power Supply Manufacturing Date	
	From	To
00	January 2020	September 2021
01	October 2021	May 2023
02	August 2023	March 2025
03	April 2025	To date

**Figure C.1** Location of the Model Data Label on the back of the Power Supply



**Figure C.2** Locating the Manufacturing Date







---

# Index

---

## Numerics

- 20kHz System Stack Assembly 67
- 30kHz System Stack Assembly 68
- 40kHz System Stack Assembly 69

## A

- About this Installation Guide 36
- Acorn nut 72
- Actuator 19
  - alone 50
    - Manual Set 14
    - small parts 41
- Actuator (alone) 40
- Actuator Mounting Bolts 41
- Actuator Settings 171
  - Cylinder Size 171
  - Stroke Length 172
- Adjust Setup Submenu 97
- Adjusting the Weld Setup 96
- Air Consumption 270
- Air filter 47, 79
- Air Filter specs 47
- Alarms
  - Cycle Modified 197
  - Equipment Failure 197
  - No Weld 198
  - Overload 245
  - Process 198
  - Setup 198
- Allen wrench
  - M8 41
- Amplitude Control 170
- Applications 22
- Assemble the Acoustic Stack
  - For a 20 kHz System 67
  - For a 30 kHz System 68
  - For a 40 kHz System 69
- Assembling the Acoustic Stack 70
- Assemble the Acoustic Stack 67
- Auto Seek, description 15
- Automation 55, 265
- AutoTune with Memory (AT/M), description 15

## B

- Base Mounting Centers 49
- Basic installation 36
- BGRAM Battery Replacement 259
- Beepers

- Turning On and Off 169
- Booster 20
- Booster clamp ring 67
- Branson
  - how to contact 8
- Branson Actuator 53
- Branson representative 76

## C

- Cable-length limits 52
- Cables 41
- Centering 15
- Circuit Boards 254
- Circuit Descriptions 81
- Circuits 195
  - Block Diagram, Power Supply and Actuator 195
  - Interconnect Diagram, Power Supply 196
- Clear/Delete key 21, 93
- Cold Start 249
  - Performing 250
- Column Clamps 38, 40
- Commands
  - Enter 21
- Compliance with Safety Standards 5
- Connect factory air 50
- Connecting Tip to Horn 71
- Connections
  - Rear of Power Supply 52
- Controls 21
- Converter 19
- Converters and Boosters 82
- Counterbalance spring 38, 40
- Cover 252
- Cycle Modified Alarms 197

## D

- Damage from shipping 37
- Data Receive 56
- Data Send 56
- Date, Setting System 168
- DB-9 format connector 56
- Decrease key 21, 92
- Detail of Rack Mount Handle Kit Assembly 65
- Diagnostics
  - Definition of screen terms 149
  - Menu map 147
  - Using the Diagnostics Menu 147
  - Viewing 148
- Digital Filter 182
- Digital Power Supply 81
- Digital Tune, Setting 150
- Digital UPS Setup 122
- DIP Switch (SW1), Functions 60
- DIP Switch Location on Analog Power Supply Module, Default Settings 61
- DIP Switch Position, User I/O 60
- DIP switch settings, Power Supply Module 63

- changing 62
- DIP switch SW1, User I/O 56
- Disclaimer of Warranty 6
- Display Control keys 21
- Display Cursor Control keys 92

**E**

- EDP numbers 70
- Electrical Connections
  - from Power Supply to a 2000-series Actuator 54
- Electrical connections between Power Supply and Actuator 53
- Electronic Power Supply Module 15
- Electro-static discharge 61
- Emergency Stop Button
  - reset 64
- Emergency Stop Control 64
- Emergency Stop signal 64
- Emissions 4
- Energy 106
- Energy Weld Mode
  - Setting Weld Energy 106
  - Using 104
  - Weld Setup Menu 104
- Enter key 21, 93
- Environmental Specifications 30, 78
- Equipment
  - Returning 33
- Equipment Failure Alarms 197
- External Presets 180

**F**

- Factory Air Supply 47
  - clean Specs 47
  - maximum pressure 47
- Factory default setting
  - for DIP Switches 60
- Fans
  - rear-mounted 52
- FAQ
  - 2000 Series Automation 266
- Features for User I/O Outputs 179
- Fixture Bolts and Washer 41
- Frequency Offset Control 183
- Frequency Offset, description 15
- Front Panel 21, 91
- Front Panel Controls 91
- Front Panel Membrane 255

**G**

- General Alarm Reset 167
- Go Back/Esc key 21, 92
- Graphs
  - Setting the Scale 181
- Ground Detect 53
- Ground Detect Weld Mode
  - Setting Scrub Time 111

Using 111  
Grounded Wriststrap 252

## H

Hand Held 175  
Handling and Unpacking 37  
Hazardous Voltages 61  
Help 76  
Hold Time  
    Setting 114  
Horn 20  
Horn Down 93  
    Using the Horn Down Feature 184  
Horn Down key 21  
Horn Scan 152  
Host Computer 56  
How to contact Branson 8  
Humidity 30

## I

Increase key 21, 93  
In-line air filter 47, 79  
Input Power Plug 60  
Input Power Ratings 78  
Installation 35  
Installation Requirements 43  
Installation Steps 47, 48  
Installing the Ultrasonic Stack in the Actuator 72  
    15, 20, and 30kHz CA Stacks 72  
    40 kHz Stacks 72  
Intended Use of the System 4  
Interconnect  
    Power Supply and Actuator 52  
International Harmonized Line Cord Color Code 60  
Inventory of Small Parts 38, 40

## J

Jack screws 50

## L

LED Indicators 21  
Left and Right Arrow keys 21  
Line Filter Module 81  
Line Regulation, description 15  
Linear encoder connector 48, 50  
List of Cables 42  
Load Regulation, description 15

## M

Main Menu 21  
    Save/Recall Presets 138  
Main Menu key 92  
Maintenance  
    Routine 188  
Mounting Bolt Pattern for Hub

- Stand on Hub 50
- Mounting bolts 40
- Mounting Circles on Base 74
- Mounting holes, stripping 73
- Mounting the Fixture on the Branson Base 73
- Mounting the Power Supply 52
- Mounting the Stand
  - (Actuator on Hub-mounted column) 49
- Mounting the Stand (Actuator on Base) 48
- Mylar Washer Kit 41
- Mylar washers 67

## **N**

- No Amplitude Step 200
- Numeric Keypad 21

## **O**

- Open the Power Supply 62
- Operation 89
- Operation, Principle of 22
- Output Circuit 81
- Output Power (RF Cable) 53
- Output Signal 60
- Overload Alarms
  - Causes 246
- Overtightened 73

## **P**

- Packing material 37
- Parts 76
- Parts List 192
- Password
  - Setting 161
- Peak Power Weld Mode 107
  - Setting the Percentage of Peak Power 109
  - Weld Setup Menu 107
- Pneumatic Connections to Actuator
  - models ae/aed/aef 47
- Pneumatic Tubing and Connectors 47
  - + Increase key 21
- Power Button 21
- Power Level % Indicator 21
- Power Level Percentage Indicator 21
- Power Supply 19
  - Manual Set 14
  - Models 14, 15
  - Module Options DIP Switch 61
  - Selecting Units for 160
  - Small parts 41
  - Testing 94
- Power Supply Connections
  - Rear 52
- Power Switch 254
- Power Switch, Lamp 254
- Precautions 3
- Preset Not Available 228

- Presets
  - Clearing 143
  - Recalling 142
  - Resetting the Counter 163
  - Setting 139
  - Setting and Recalling 137
- Principle of Operation 22
- Print key 21
- Printing
  - Print key 21
- Process Alarms 198
- PVC Materials 4

## Q

- Questions 76
- Quick- disconnect fitting 50

## R

- Rack Mount handle kit 65
- Rack mount handle kit 52
- Rack Mount Installation 65
- Ready to weld 36
- Rear view of Actuator 51
- Receiving 31
- Rectangular horn 70
- Requirement Specifications 78
- Reset key 21, 93
- Returning Equipment 33
- RFI Compliance 4
- RS-232 56
- RS-232c 56
- Rubber feet 52
- Run key 21, 92
- Run Screen 95
  - Adjusting Weld Setup 97

## S

- Safety
  - Guards 64
  - PVC Materials 4
  - Requirements and Warnings 2
  - Workplace 4
- Safety Equipment 64
- Select key 21, 92
- Select keys 21
- Select Start, description 15
- Selecting a Weld Mode 100
- Serial (RS-232) Port 56
- Serial Port
  - Baud Rate 164
  - Setting Parameters 164
- Serial port 56
- Setting Hold Time 106, 114
- Setting Scrub Time 111
- Setting Weld Energy 106
- Setting Weld Parameters 99

- Setting Weld Parameters, Other 114
  - Setting Afterburst 120
  - Setting Amplitude 115
  - Setting Control Limits 129
  - Setting Cycle Aborts 125
  - Setting Frequency Offset 124
  - Setting Limits 131
  - Setting Post Weld Seek 123
  - Setting Pretrigger 118
  - Setting Reject Limits 134
  - Setting Stepped Amplitude 116
  - Setting Suspect Limits 131
  - Setting Timeout 128
- Setting Weld Time 103
- Setup 35
- Setup Alarms 198
- Setup key 21
- Shipping and Handling 30
- Shock 30
- Signal Description 60
- Silicone grease 67
- Small Parts Inventory 41
- Software Version, Verify 260
- Sonics Disabled 201
- Spanners 41
- Special Cable requirements 53
- Stack 19, 20
- Stack Assembly Torque Tables 70
- Stand (actuator on a base) 37
- Stand (Actuator on a Hub) 39
- Standard 19-inch Rack 52
- Standard connections 53
- Start Screen 162
- Start Switch
  - Connection Codes 55
- Start Switch Connection 55
- Start switch/E-stop connections 55
- Stop button 64
- Stud Size 70
- Stud Torque Values 70
- Symbols
  - In the Manual 2
  - On the Product 2
- Sync Setup 230, 231
- System Configuration 156
  - menu description 159
  - Menu Map 157
  - Selecting a Start Screen 162
  - Setting Parameters for the Serial Port 164
  - Setting the Amplitude Control 170
  - Setting the Cylinder Diameter 171
  - Setting the Cylinder Stroke 172
  - Setting the Frequency Offset Control 183
  - Setting the Scale for Bar Graphs 181
  - Setting the System Date 168
  - Setting the System Time 168
  - Turning Beepers On or Off 169

- Turning the Digital Filter On or Off 182
- Turning the General Alarm Reset On or Off 167
- System configuration
  - Resetting the Presets Counter 163
- System Information 153
  - Viewing 153, 154
- System Menus 95
  - Adjusting the Weld Setup from the Run Screen 96
  - Run Screen 96
  - Using the Run Screen 95
  - Viewing Weld Results 97
- System Protection Monitor (SPM), description 15

## T

- Technical Specifications 78
- Temperature
  - Shipping and Storage 30
- Test 21
  - Using the Test Feature 185
- Test key 21
- Testing the Installation 75
- Testing the Power Supply 94
- T-Handle Wrench 41
- Time
  - Setting 168
- Time Weld Mode
  - Setting Control Limits 129
  - Setting Frequency Offset 124
  - Setting Post Weld Seek 123
  - Setting Pretrigger 118
  - Setting Reject Limits 134
  - Setting Suspect Limits 131
  - Using 101
- Tip to Horn connection 71
- Toolkit 38, 40
- Tools 249
- Torque 68
  - carriage door 72
- Torque Tables
  - Stack Assembly 70
- Torque wrench 70
- Trg Delay Timeout 208
- Troubleshooting 197

## U

- U53, U54, U55, and U56, Location and Orientation 260
- Ultrasonic Converter 40
  - J-Type for stand-alone use 40
- Ultrasonic Energy 53
- Ultrasonic Power Module
  - Main Circuits 81
- Ultrasonic Stack
  - Installing in the Actuator 72
- Unpack
  - Actuator 37
  - Power Supply 37

- Stand 37
- Unpack the converter 40
- Unpacking 32
- Unpacking and Handling 37
- Up and Down Arrow keys 21
- User Definable I/O 178
- User I/O Cable Identification 56
- User I/O DIP Switch 60
- User I/O Input and Output Function Selection 59
- User I/O Input Features 178
- User I/O Inputs 178
- User I/O Interface 56
- User I/O Output features 178
- User I/O, Configuring 177
- Using Welder Address 166

## **V**

- VFD Display 255
- Vibration 30

## **W**

- Warranty 6
- Weld Energy
  - Setting 106
- Weld Modes
  - Selecting 100
  - Summary 99
- Weld Parameters 99
- Weld Results
  - Viewing on the Display 97
- Weld Setup 97
  - Adjusting 97
- Weld System Applications 22
- Weld Time
  - Setting 103
- Welding 17
- Welding System 17
- Welding Systems 22
- Workplace 4
  - setting up 4
- Write In Fields 136

